

Hisense VRF

Hisense



Head office : unit14,no8,Bastami alley,Shariati St
TEHRAN/1556935337 Email:info@tahviehoorsan.com
TelFAX: +9821 88739856 www.tahviehoorsan.com

Qingdao Hisense HVAC Equipment Co., Ltd.
Hisense Tower, Qingdao, China

<http://www.hisensehvac.com> export@hisensehitachi.com [HisenseHVACGlobal](#) [Hisense HVAC](#) [Hisense HVAC](#)



★ Design and specifications are subject to change without notice. Pictures and diagrams are for reference only and are subject to change without notice.
All rights reserved by Qingdao Hisense HVAC Equipment Co., Ltd.

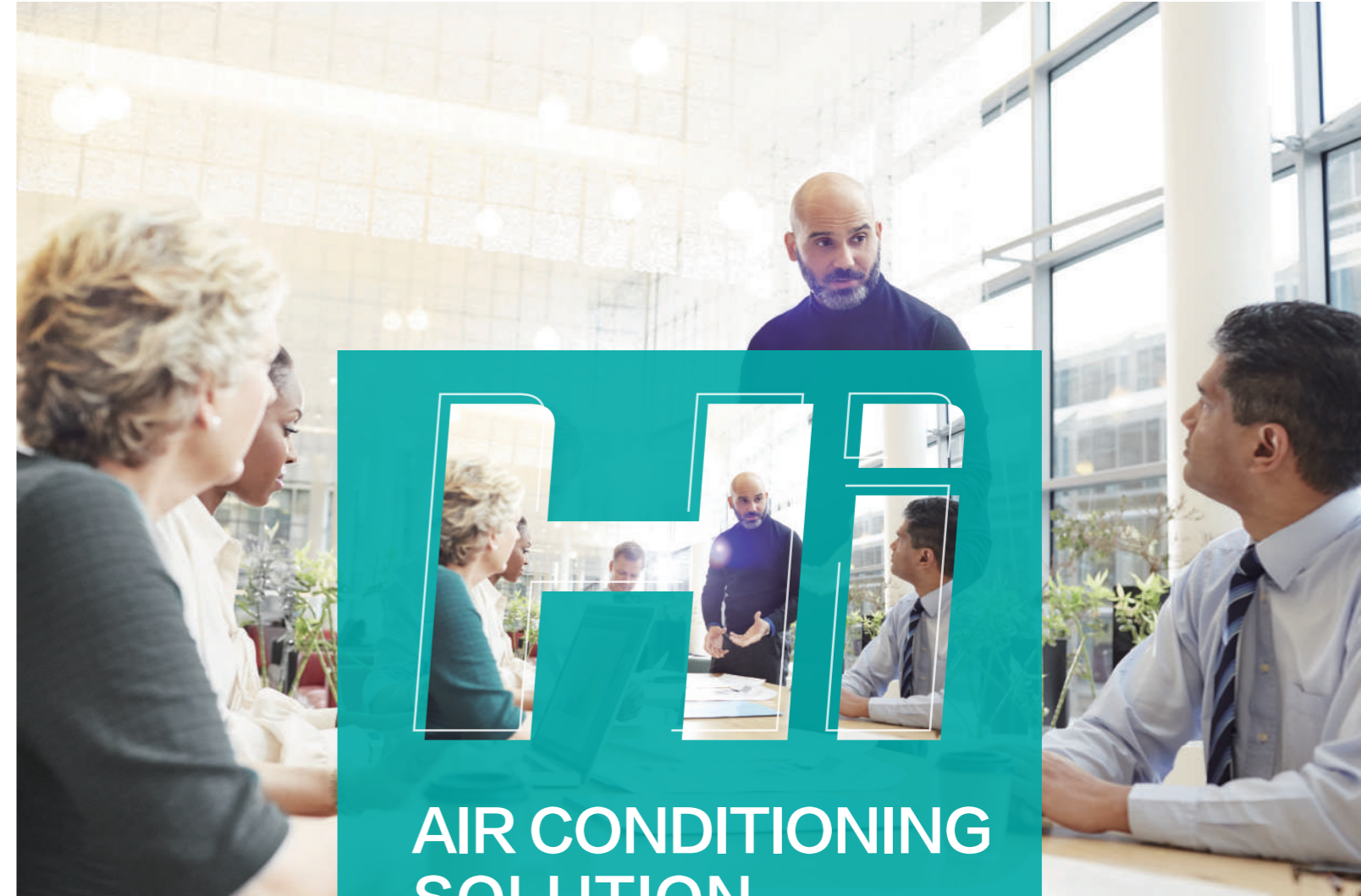

**AIR CONDITIONING
SOLUTION**

Reimagine your solution



Hisense SINCE 1969

Hisense Group is a well-known large-scale electronic information industry group company. Based on technology and focusing on innovation-oriented culture, its scientific and efficient technological innovation system makes Hisense always be at the forefront of the counterparts. Hisense brand family has continued to grow with Toshiba, Gorenje and ASKO. Multi-brand operations will be defined according to Group's Strategy Management Department.

SINCE 1969

BUSINESS LAYOUT

Multimedia

- TV and Display Devices
- Internet TV Operation
- Mobile Communication Devices
- Optical Communication Devices
- Chip

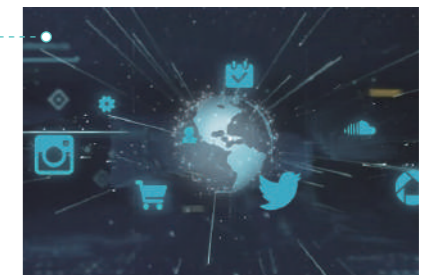

Household Appliances

- Refrigerator
- Freezer
- Air-conditioner
- Washing Machine
- Kitchen Appliance



IT Smart Systems

- Smart City
- Smart Community
- Smart Transportation
- Smart Business
- Medical Electronic Devices
- Smart Home System and Service

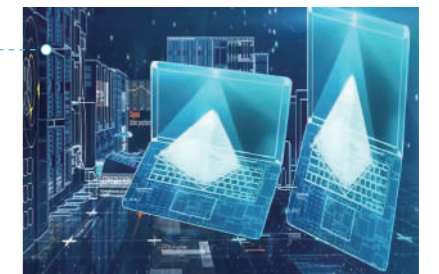

Real Estate & Modern Services

- Real Estate
- High-end Plaza Chains
- Mould Design and Manufacturing
- Finance
- Trade



GLOBAL HISENSE SINCE 1969

Hisense has started a long-term sports marketing strategy to increase brand awareness worldwide. After the successful sponsorship of **UEFA EURO 2016&2020** and **FIFA WORLD CUP 2018**, Hisense has made clear its focus on football. And now, Hisense becomes the official partner of **FIFA WORLD CUP 2022**.

2014 Official Sponsor of the Australian Open

2015 Team Supplier to Red Bull Racing

2016 Official Partner of UEFA EURO 2016

2018 Official Sponsor of the 2018 FIFA World Cup

2020 Official Partner of UEFA EURO 2020

2022 Official Sponsor of the 2022 FIFA World Cup



Hisense HVAC MANUFACTURING BASE

Qingdao Hisense HVAC Equipment Co., Ltd. is a wholly owned subsidiary of Qingdao Hisense Hitachi Air-conditioning Systems Co., Ltd., who is a joint-venture of Hisense and Hitachi (changed to Johnson Control Hitachi in 2015) and was established in 2003.

It integrates technology development for commercial and residential central air conditioners, product manufacturing, marketing and service as a whole. With the full support of all the shareholders such as Hisense and Johnson Control Hitachi, Hisense HVAC is committed to becoming the market leader in the industry.

With solid technical innovation strength, Hisense HVAC has participated in the formulation and revision of 50 national standards, industry standards and association standards, and has 1045 authorized patents in the field of CAC and heat pump products. Since 2008, 65 technologies have reached the advanced level through authorized certification. Now Hisense HVAC has become a leading CAC enterprise in China.

Note: The above data is valid before Dec. 31th, 2021.



266,000 m²
Manufacturing Area



40+
Production Line



6,000,000 units/year
Production Capacity



16,700 m²/70+
Laboratory



CONTENTS



03
RELIABILITY



25
COMFORT



41
OUTDOOR UNIT



155
CONTROL SYSTEM

17
EFFICIENCY



33
FLEXIBILITY



117
INDOOR UNIT



173
ACCESSORIES &
ENGINEERING TOOLS

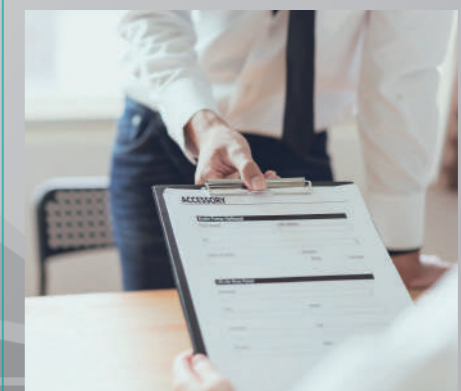

RELIABILITY

Refrigerant Circuit

Enhanced Anti-corrosion Solution

System & Operation

Electrical & Electronics

Indoor Unit Reliability

Refrigerant Circuit

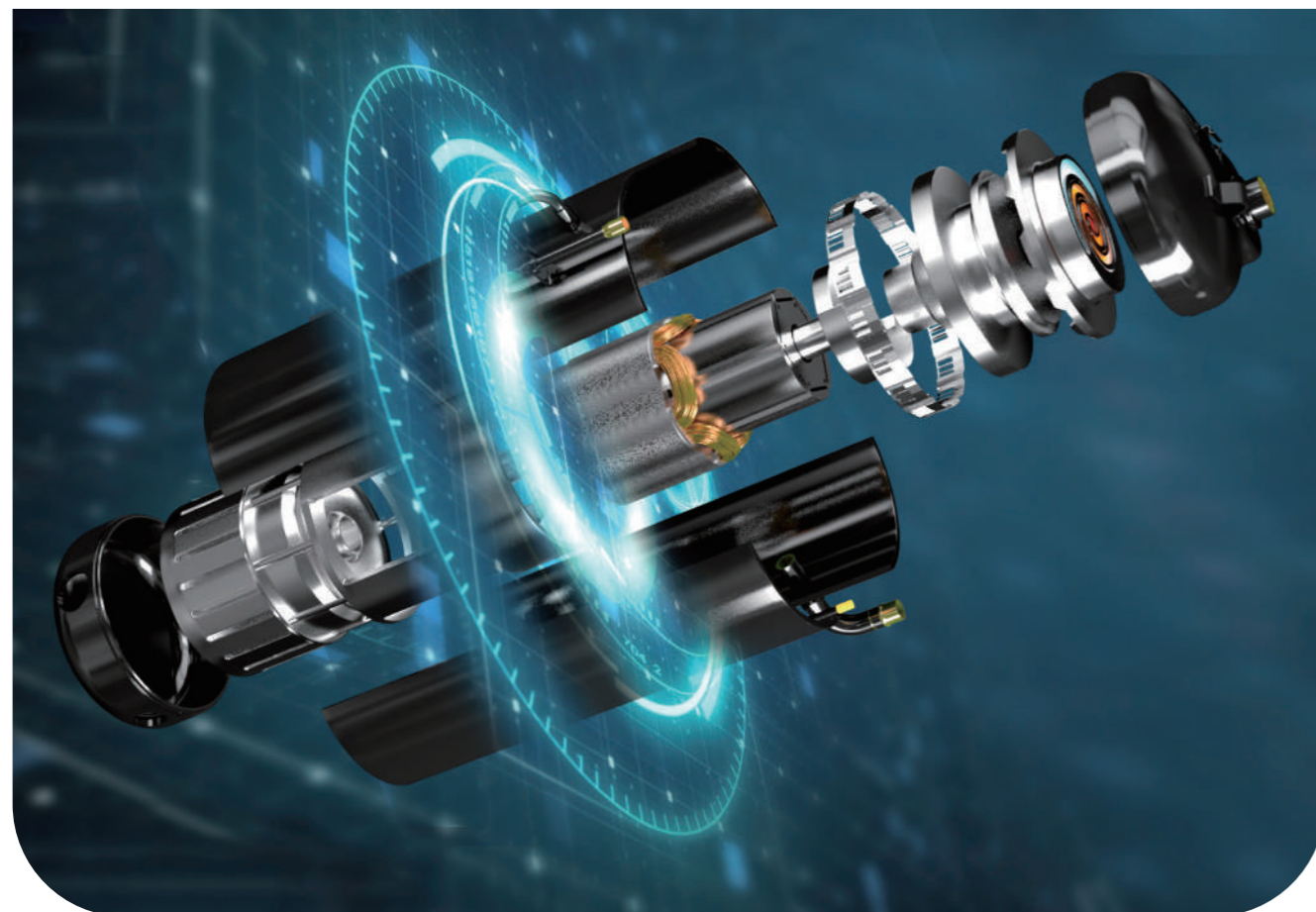

Efficient energy usage

Wasted power is reduced by minimizing leakage and anti-overcompression while compressing refrigerant gas with asymmetric scroll and patented release valves.

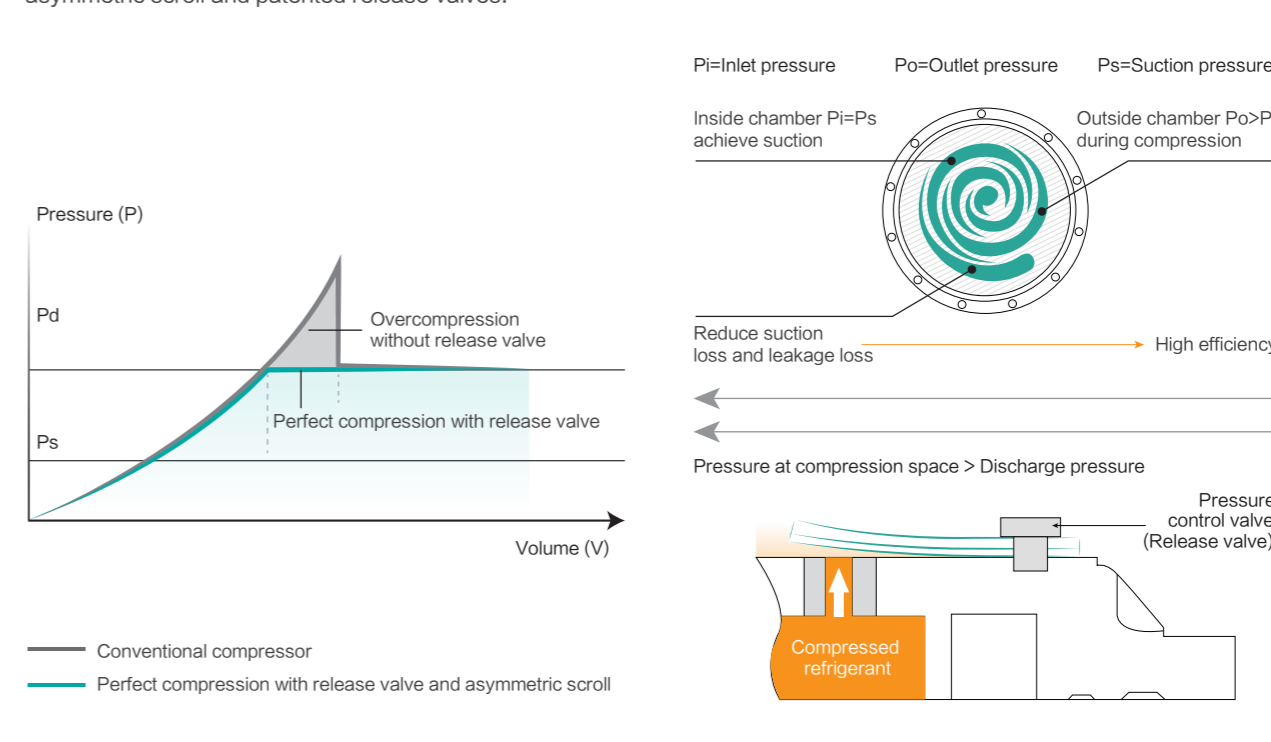

Enhanced oil level retaining capability

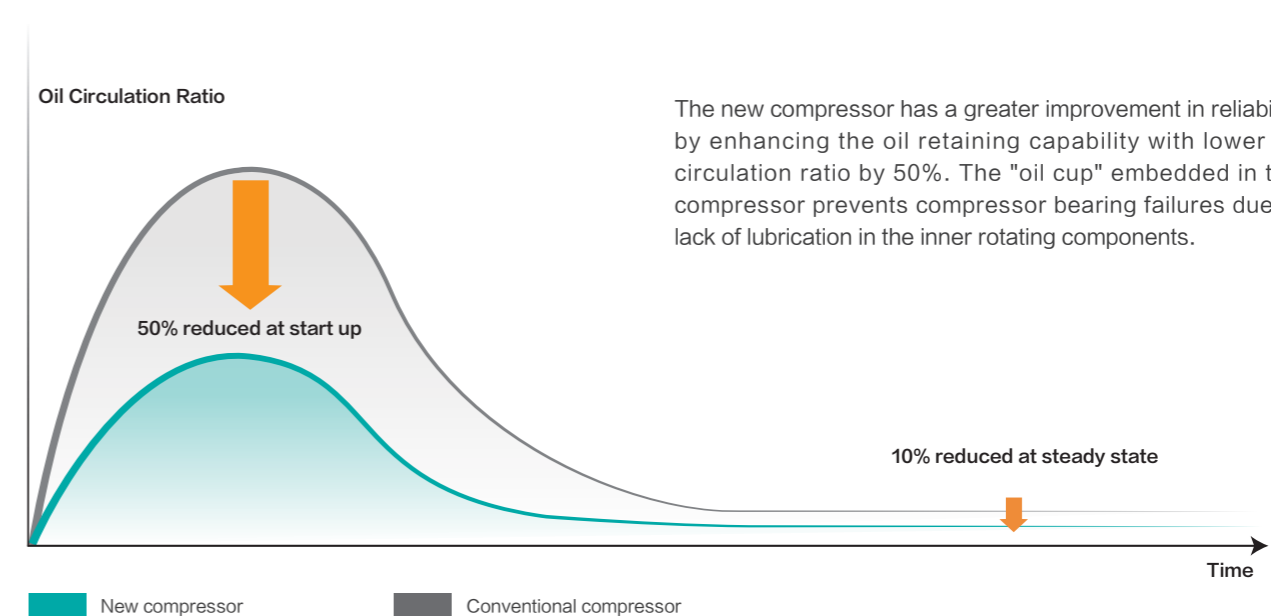

The new compressor has a greater improvement in reliability by enhancing the oil retaining capability with lower oil circulation ratio by 50%. The "oil cup" embedded in the compressor prevents compressor bearing failures due to lack of lubrication in the inner rotating components.

Revolutionary HVAC compressor

Vapour injection technology

New generation scroll compressor is now patented with higher performance capability vapour injection technology, increasing capacity up to 25% compared to conventional scroll compressor with same amount of power consumed.

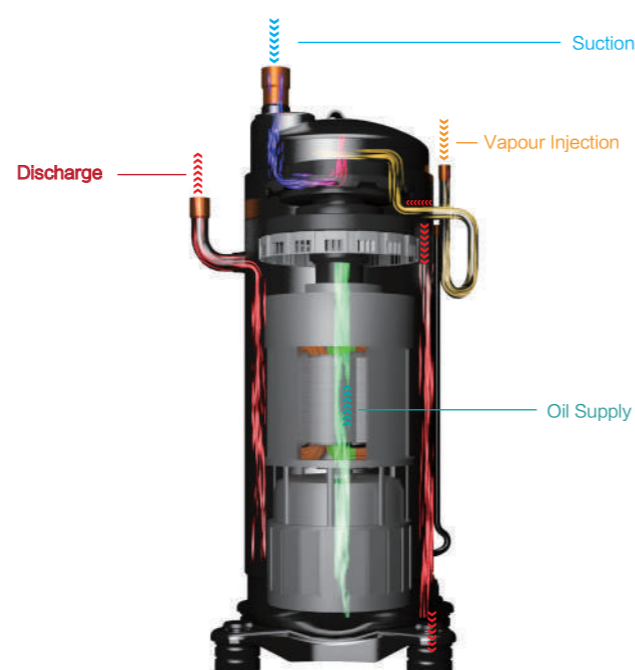



Oil separation and oil return

Oil separation

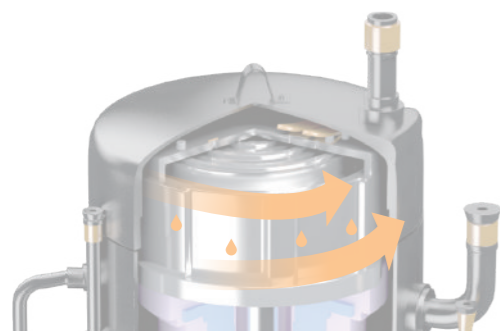

First-stage Oil Separation

First-stage oil separation is realized through efficient oil separation structure inside the high-pressure-chamber compressor. Only a small amount of oil is brought out of the compressor.

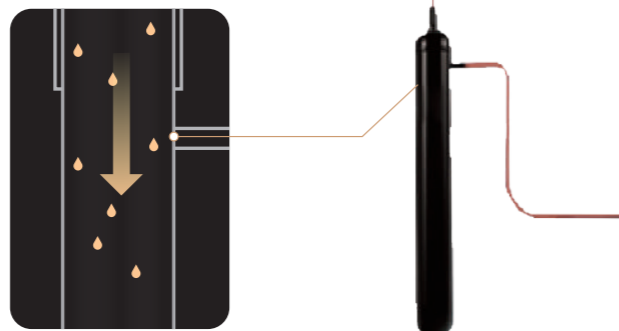

Second-stage Oil Separation

During second-stage oil separation, the small amount of oil discharged from compressor is separated by a large-capacity high-efficiency centrifugal oil separator, with efficiency over 99%.

Oil return

The accumulator adopts pore tube oil return technology with a built-in fine strainer, which not only ensures oil balance between compressors within one module, but also plays an important role in the oil balance between modules.

Besides this, the system implements oil-return function based on compressor frequency and corresponding operation time. The oil-return takes 60 seconds and can return to previous condition when it is finished.

In winter under heating mode, this operation is implemented without switching to cooling mode, which guarantees the heating performance.

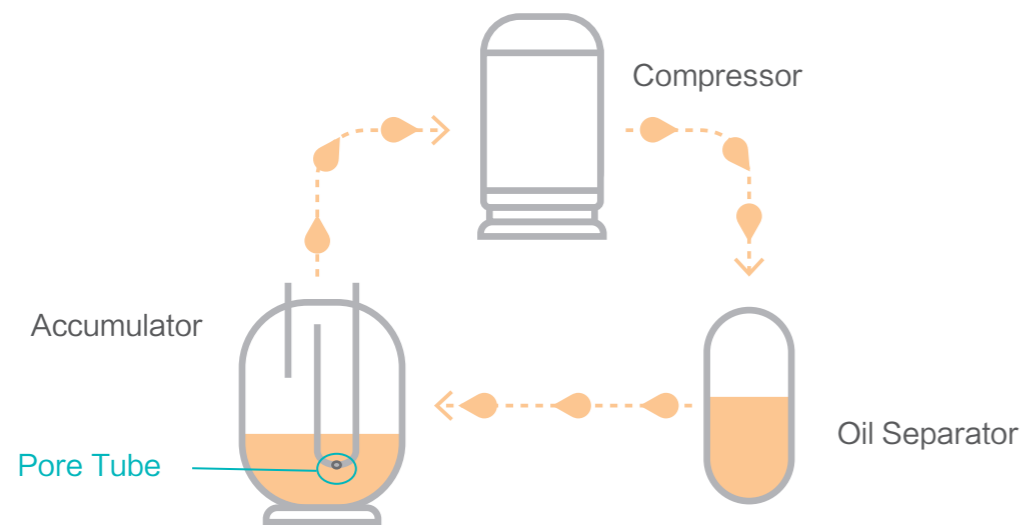

Enhanced Anti-corrosion Solution

Hisense's complete corrosion-proof is a perfect solution in seaside and chemical factory applications (sulphide contamination occasion), providing ultimate comfort without sacrificing life span and reducing maintenance cost simultaneously.

The components from top to toe are treated with effect treatments, and the systems have acquired UL certification.



- 1 Front Panel** Galvanized steel treated with zirconium & 100 μm ~ 180 μm epoxy zinc rich primer + pure polyester paint coating.
- 2 Heat Exchanger** Black fin (with epoxy resin & hydrophilic film); Cooper fin.
- 3 Electrical Box** Galvanized steel treated with zirconium & 50 μm~120 μm pure polyester.
- 4 Fan Motor** Coated with 10 μm ~ 30 μm Acrylic Resin coating Thickness: 10 μm ~30 μm.
- 5 Top Grill**
- 6 Motor Bracket**
- 7 Protection Net**

Note

Please refer to the catalog of Hisense VRF Anti-corrosion Solution for detailed anti-corrosion treatment measures.

System & Operation



Self-diagnosis & self-protection measures

Self-diagnosis

Operation monitoring and maintenance are made simpler by having the AC unit tells you what and where is wrong with them. Alarm codes will be flashed out when an error or breakdown occurs. Extremely helpful for installers during test run and also end-users to understand what's going on. Besides alarm codes, operating status and parameters like history temperature, pressure, compressor frequency and etc are traceable on controllers and the outdoor unit, easing service maintenance and troubleshooting.

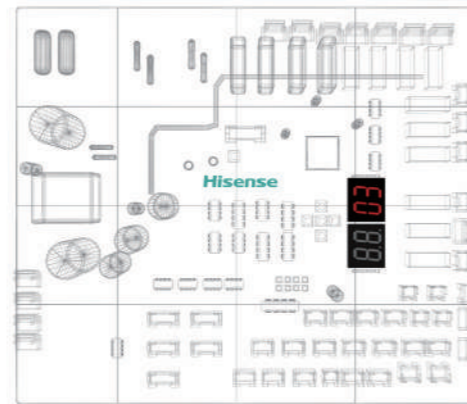

Self-protection

Hisense VRF can protect itself with algorithms embedded to make necessary protective decisions and measures by different sensor readings and parameters, including compressor protections, system protections, inverter protections and electric protections.



Smart rotative operation & triple backup operation

Smart rotative operation

Operation duties are smartly balanced in higher capacity module combinations to prevent occurrence of individual unit overworked and hence extending the overall operating life of the overall system.

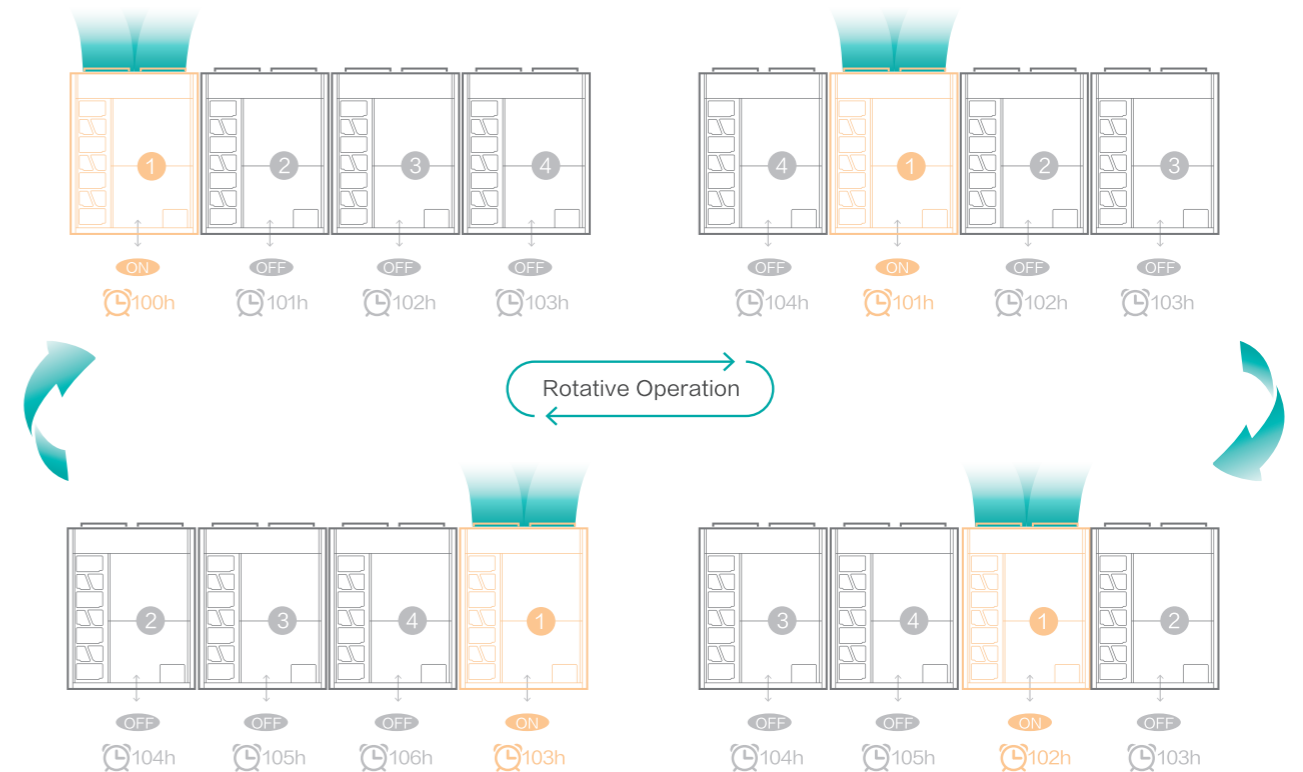

Triple backup operation

Module backup operation

If one module in a combination system malfunctions, the other ones can still keep working to ensure an emergency operation until service and repair.



Compressor backup operation

In the single module system equipped with two compressors, if one compressor malfunctions, the other one can provide emergency operation. In the combined modules, if the compressor in one module goes wrong, the other modules can provide emergency operation. Thus a stable and continuous operation can be ensured thanks to the backup of compressors.

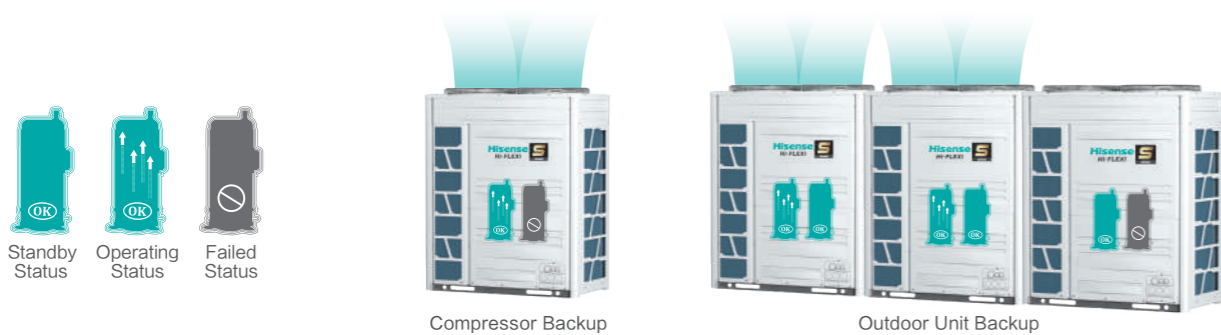

Fan backup operation

For the module equipped with two fans, if one fan breaks down, the other one won't be influenced, the module can still keep working.



Snow hood (optional)

The snow hood kit can effectively prevent heavy snow from accumulating on the top of the unit and covering the heat exchanger. Heavy snow accumulating will affect the heat exchange seriously, thus stable operation can be ensured thanks to the snow hood.

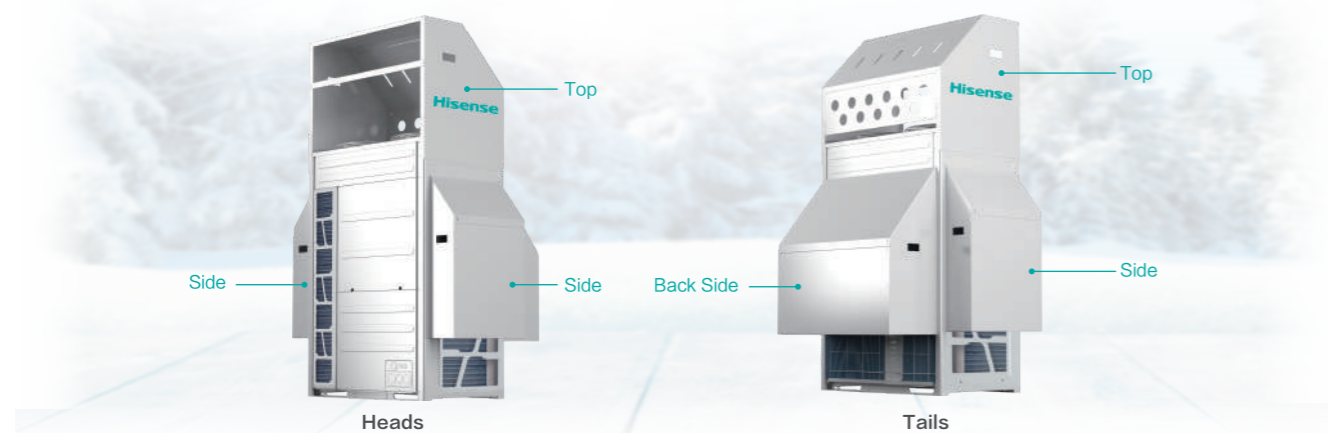

Wider operation range

Extended operation range creates wider application potential, in cooling mode the operation range is from -5°C DB to 52°C DB and in heating mode the operation range is from -25°C WB to 16.5°C WB, which adapts to extreme conditions.

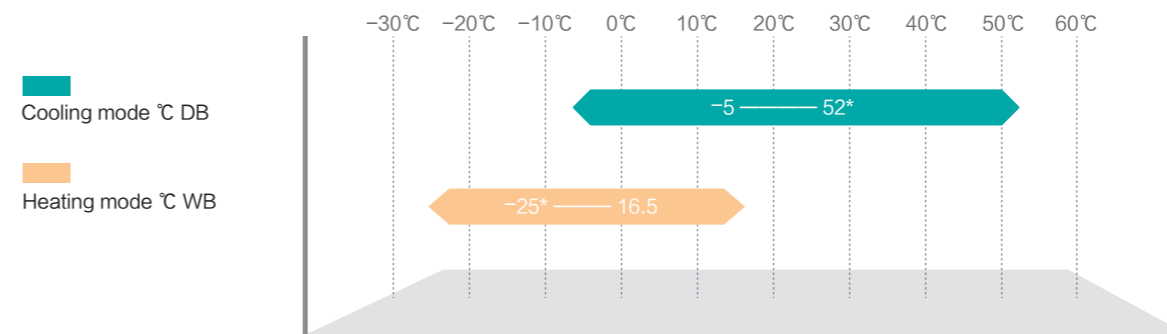

Note

1. When the temperature is in 48°C~52°C and -20°C~ -25°C, the module is in intermittent operation.
2. The dry temperature range of heating operation mode is from -25°C to 26°C.
3. Please refer to the specification table of each series for detailed operation range.

Automatic Restart

Hisense indoor units are capable to restart automatically to the previous state whenever the power supply is shut off suddenly and restores immediately. When there is long power shortage, the default setting is to keep all the indoor units off when the power restores. Also there are two other settings for users' choice, recovering to the state before power failure or restarting all the indoor units.

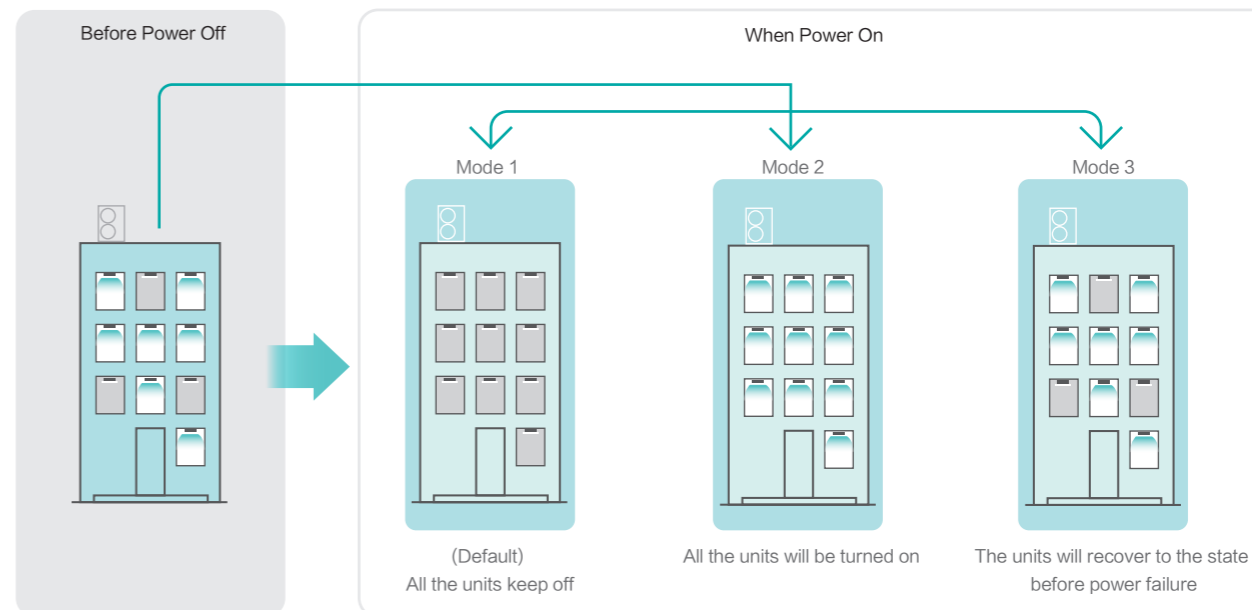

* DIP setting is necessary for mode 2 and mode 3.

Electrical & Electronics

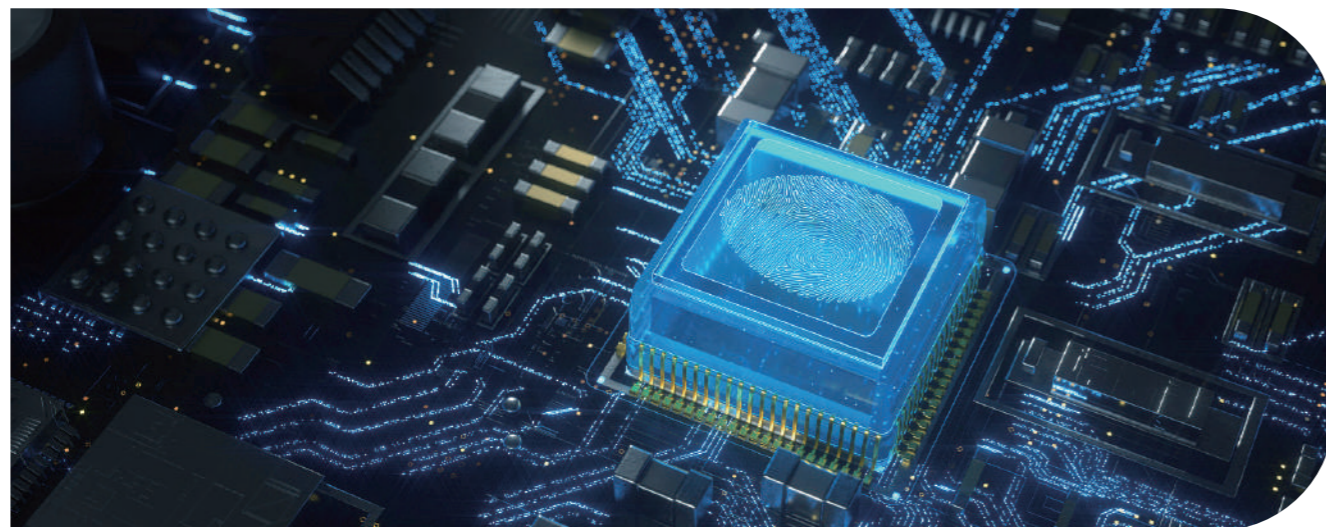

Patented 360° fitted refrigerant cooling technology

Hisense VRF uses refrigerant cooling technology to cool the electrical control box. It overcomes the poor heat dissipation and high ambient temperature issues to maintain efficient operation even at harsh environment. Compared with air-cooled technology, the temperature inside the electrical box can be reduced by up to 20%*. Moreover, the refrigerant cooling kit adds a temperature sensor, which could be more precise to control the refrigerant cooling temperature and ensure the whole reliability.

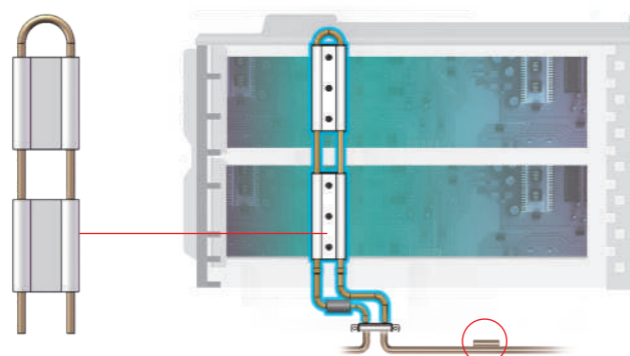

Note

1. * The data is based on the S mavo+ unit under low fan speed operation. 2. Temperature sensor is only available for S mavo+ series.

Insect protection design

Special design nettings are placed on insect easy-entry openings, effectively preventing unnecessary electrical component damages.

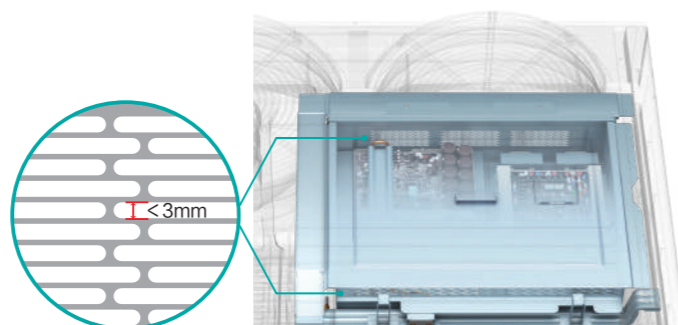

Voltage protector reserved (optional)

Too low or too high voltage can easily damage the electronic components. The new generation of top flow unit has reserved the space for assembling the voltage protector, which can be an effective solution to protect outdoor units from any voltage spikes. The power supply of outdoor unit will be automatically cut off when there is abnormal voltage, and will be restored when power supply returns to normal after 30s. Meanwhile, it's helpful for checking the phase sequence error or phase loss according to the indicator lights, convenient for commission and maintenance.

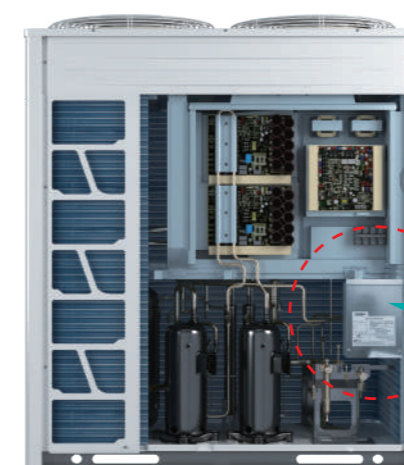

Can bear **15000** times actions



Can be installed in the factory or on site

Quality electrical and magnetism precaution measure

Air-conditioning unit produced by Hisense VRF requires strict electromagnetic protection and preventive quality assurance to not allow electromagnetic wave from other devices surrounding the unit to interfere the normal operation and function of our unit and vice versa onto other equipment. Another typical damage causes of electronic and electrical failure is sudden high external power source exerted into the electronic compositions like thunder strike during a storm. As to overcome such inevitable natural phenomenon to cause damage, 4000V sudden high voltage test is infused into the long list of electromagnetism quality test in our internationally qualified test lab.



Indoor Unit Reliability



Independent maintenance of indoor unit

To maintain the whole system's continual operation even when there is a breakdown occur within a system, Hisense VRF is capable to isolate the malfunction unit from the others while conducting restoration and maintaining continuous operation of other units simultaneously. Especially practical for retail shops or offices where multiple indoor units share the same system, there is a breakdown or powered cut-off during renovation of a shop does not affect shops of the same system from routine business operation.

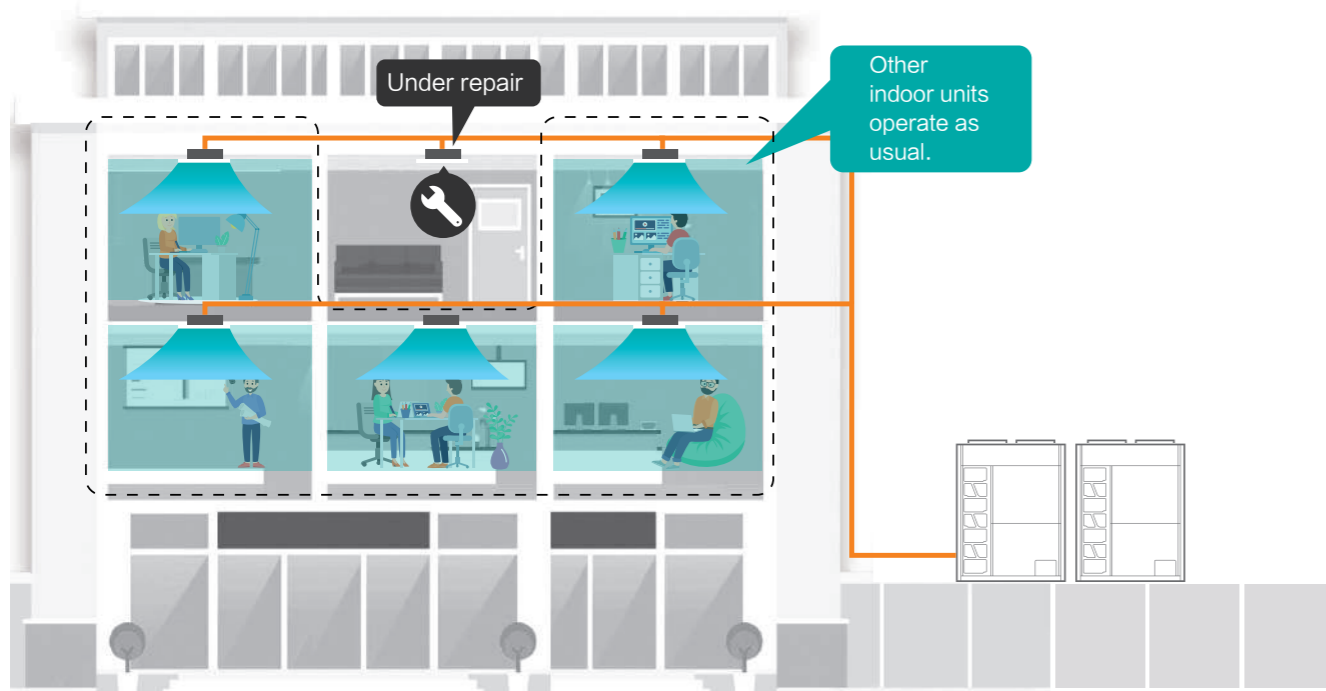

*Preliminary setting is unnecessary

Condensate water leakage protection

Indoor units have build-in water-leakage float switches. Alarming warnings will be displayed on controllers when condensate reaches a certain level. Save your ceiling and carpet from being soaked in time when drain pipe is clogged or drain pump breakdowns.

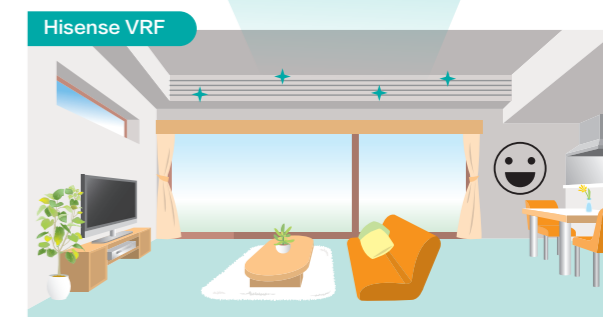
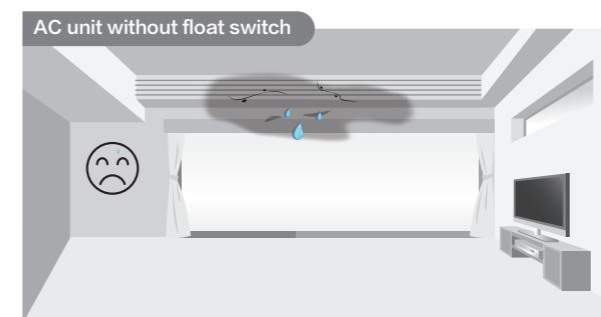
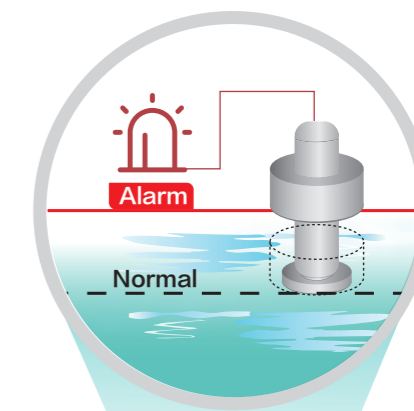

Effective drainage solution

High quality seals

Water could seep through anywhere as long as there is a void. Thus, Hisense utilizes the best quality sealing material to seal up gaps between the heat exchanger and drain pan, which effectively prevents condensate leakage.

Transparent drain pipe

To ease drainage inspection, Hisense indoor units adopt transparent drain hose connection. It enhances installation and maintenance, making sure drain hoses are connected securely and make blockage inspections much easier.

EFFICIENCY

Efficient Heat Exchanger

Intelligent Defrosting Logic

Steady Air Discharge

Efficient Heat Exchanger

New advanced corrugated fin design

The heat exchanger of Hisense VRF adopts the new advanced corrugated fin design. With this new design, larger amount of fins can be allocated into the heat exchanger, increasing 20% heat exchange surface area maximally compared with the last generation fin and the heating capability increase 10% averagely.

Long-time stable heating performance

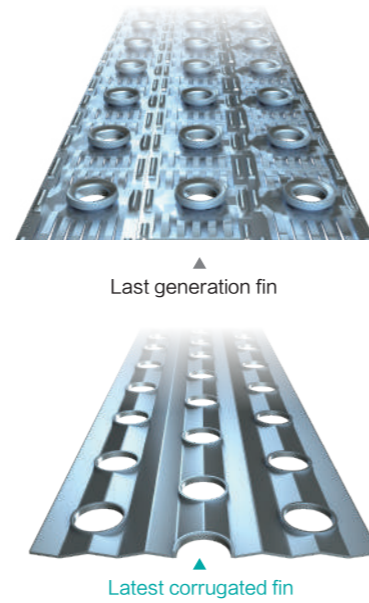
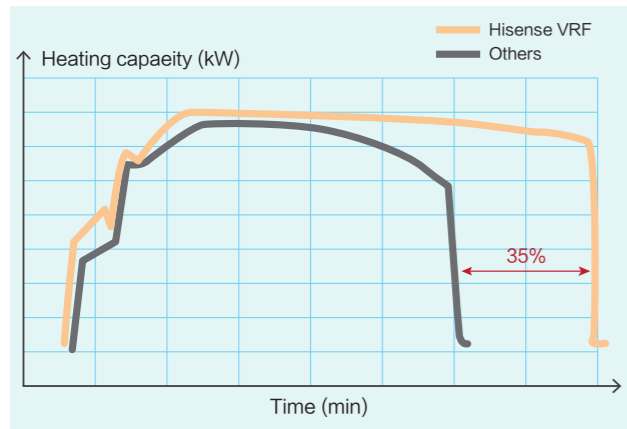

Two-stage subcooling

For the conventional VRF systems without the sub-coolers, the subcooling temperature is about 12.5°C with one-stage subcooling. However, Hisense VRF's 2-stage subcooling technology can realize the subcooling temperature up to 27°C, distinctly improving the cooling capacity by pushing refrigerant further beyond its condensing temperature.

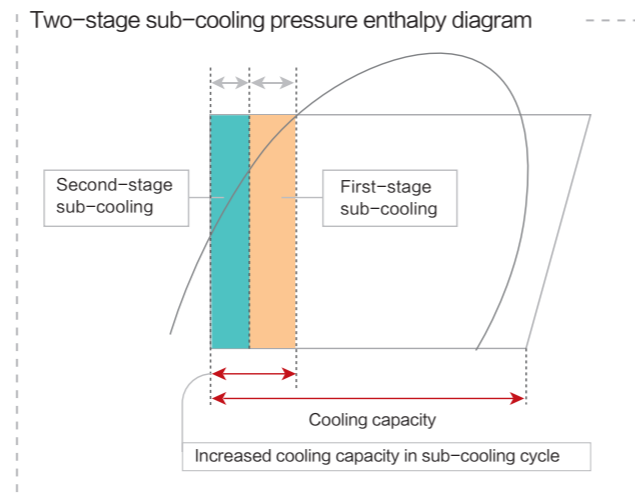
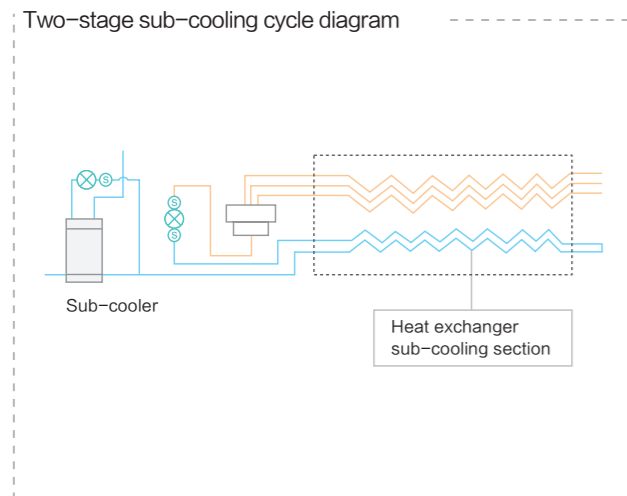

Optimized refrigerant circuit

As refrigerant flows in the system, energy will be lost due to friction and other factors naturally especially when refrigerant change phase, latent heat are lost when gas turns to liquid. Whereby, as more heat is dissipated out, higher the heat exchanger efficiency is. By making full use of heat dissipation, refrigerant flow layout is maneuvered into 2 to 1 refrigerant flow path extends liquid refrigerant's occupancy and eventually the efficiency too.

Conventional technology

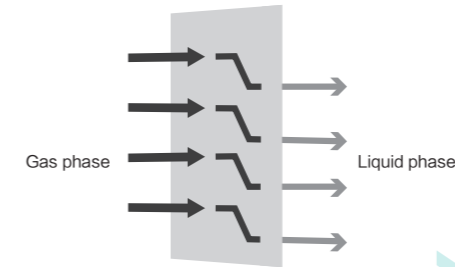

2-to-1 refrigerant flow path

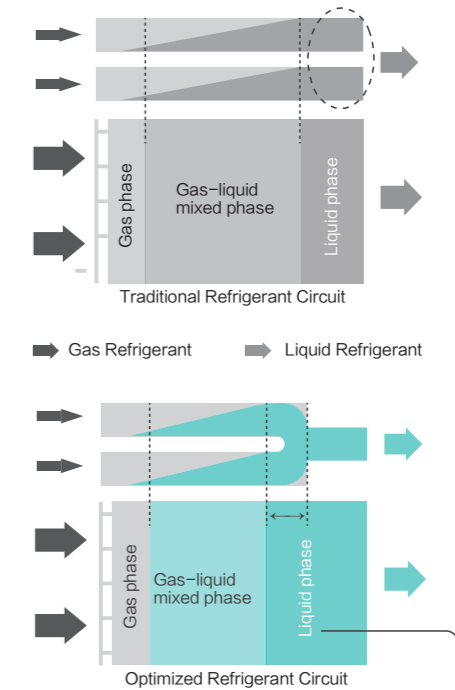
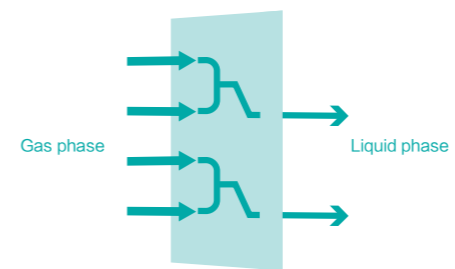

Increase the proportion of liquid refrigerant in the heat exchanger to improve heat transfer efficiency

Why does 2 to 1 refrigerant circuit is higher in efficiency?

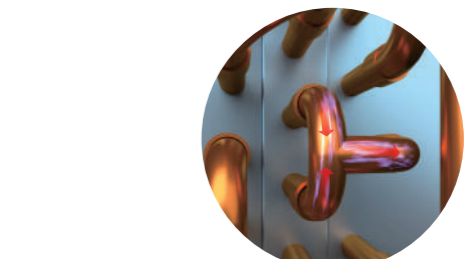
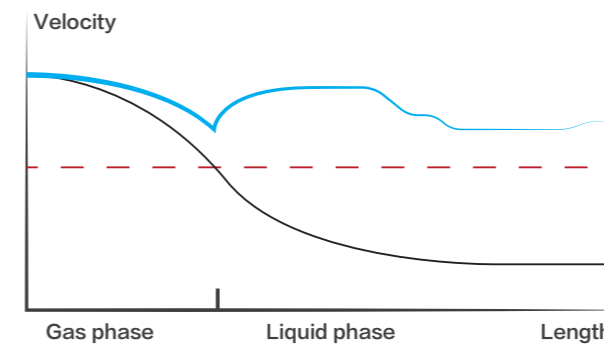

2 to 1 refrigerant circuit: velocity is maintained same goes to the efficiency of refrigerant heat exchange.
 Conventional refrigerant circuit: Heat exchange slows down with decreased velocity. Efficiency is greatly reduced.

Intelligent Defrosting Logic

PTT defrosting mode

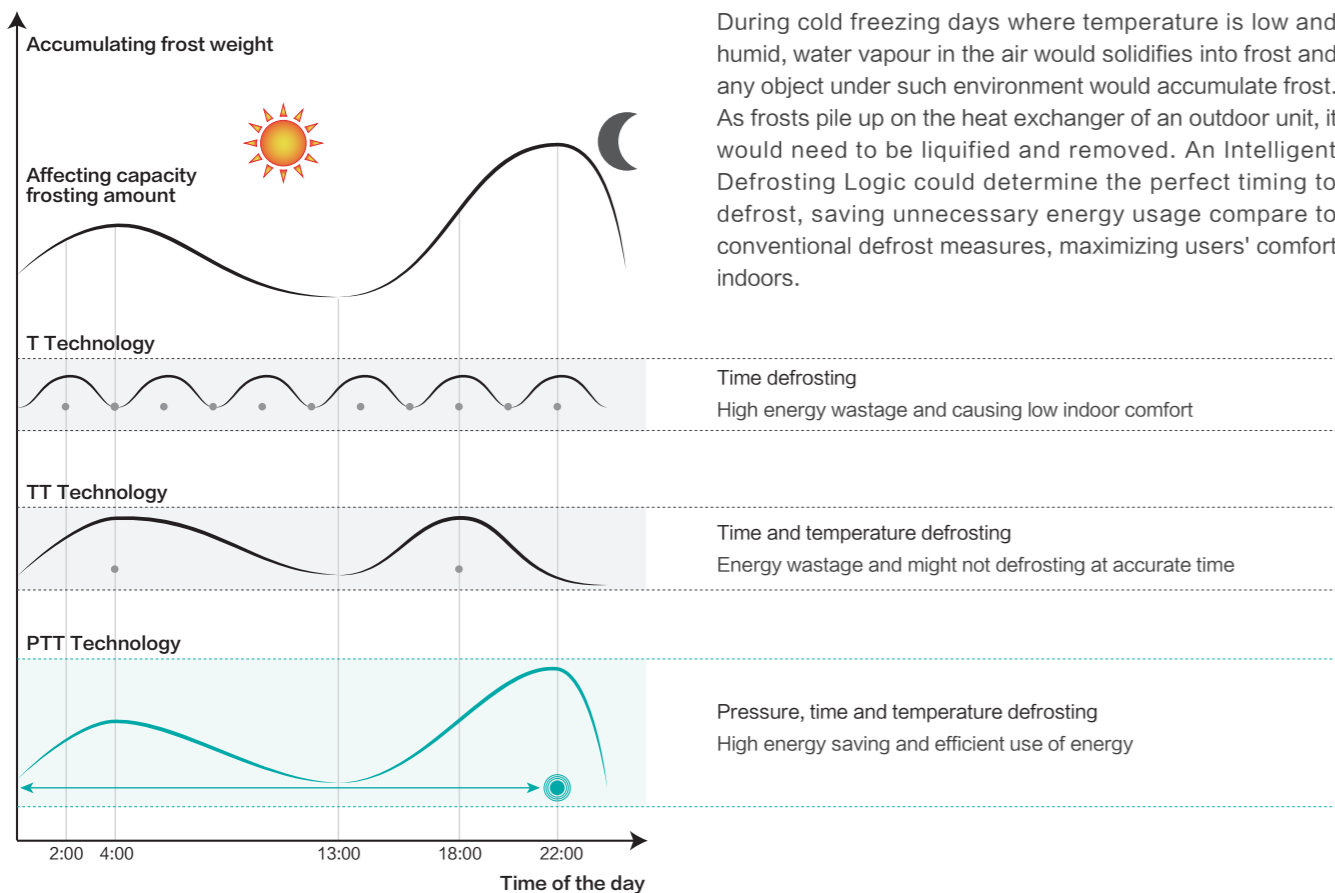

During cold freezing days where temperature is low and humid, water vapour in the air would solidifies into frost and any object under such environment would accumulate frost. As frosts pile up on the heat exchanger of an outdoor unit, it would need to be liquified and removed. An Intelligent Defrosting Logic could determine the perfect timing to defrost, saving unnecessary energy usage compare to conventional defrost measures, maximizing users' comfort indoors.

Continuous heating during defrost

Considering user's ultimate comfort in cold unbearable times, indoor heating can now be supplied continuously to prevent periodic idle intervals.

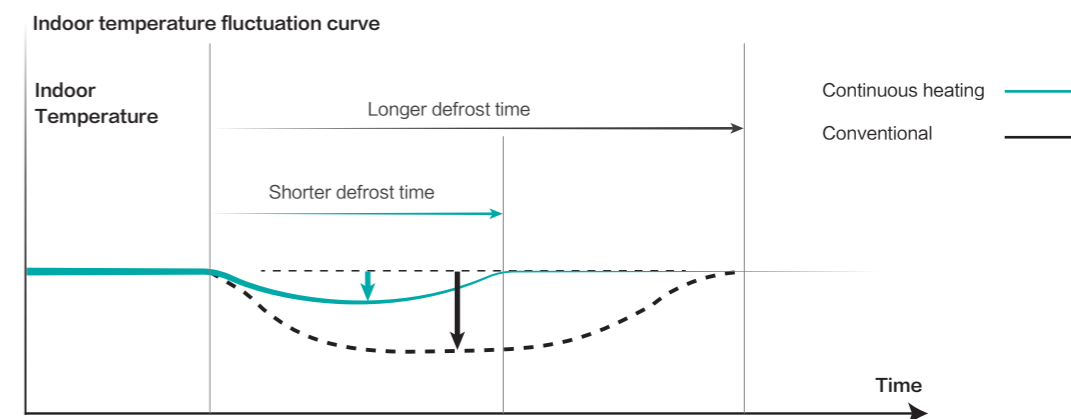

Bottom anti-frosting structure

To ensure effective frost removal, heat exchanger circuit is extended to the bottom to make sure melted frost from the top does not solidify as it reaches to the condensate drain and hence enhances smooth discharge. In the meantime, the heat also extends frost formation periods whereby prolongs defrost interval.

Extended heat exchange coils, keeping the bottom warm

Smooth continuous condensate drainage

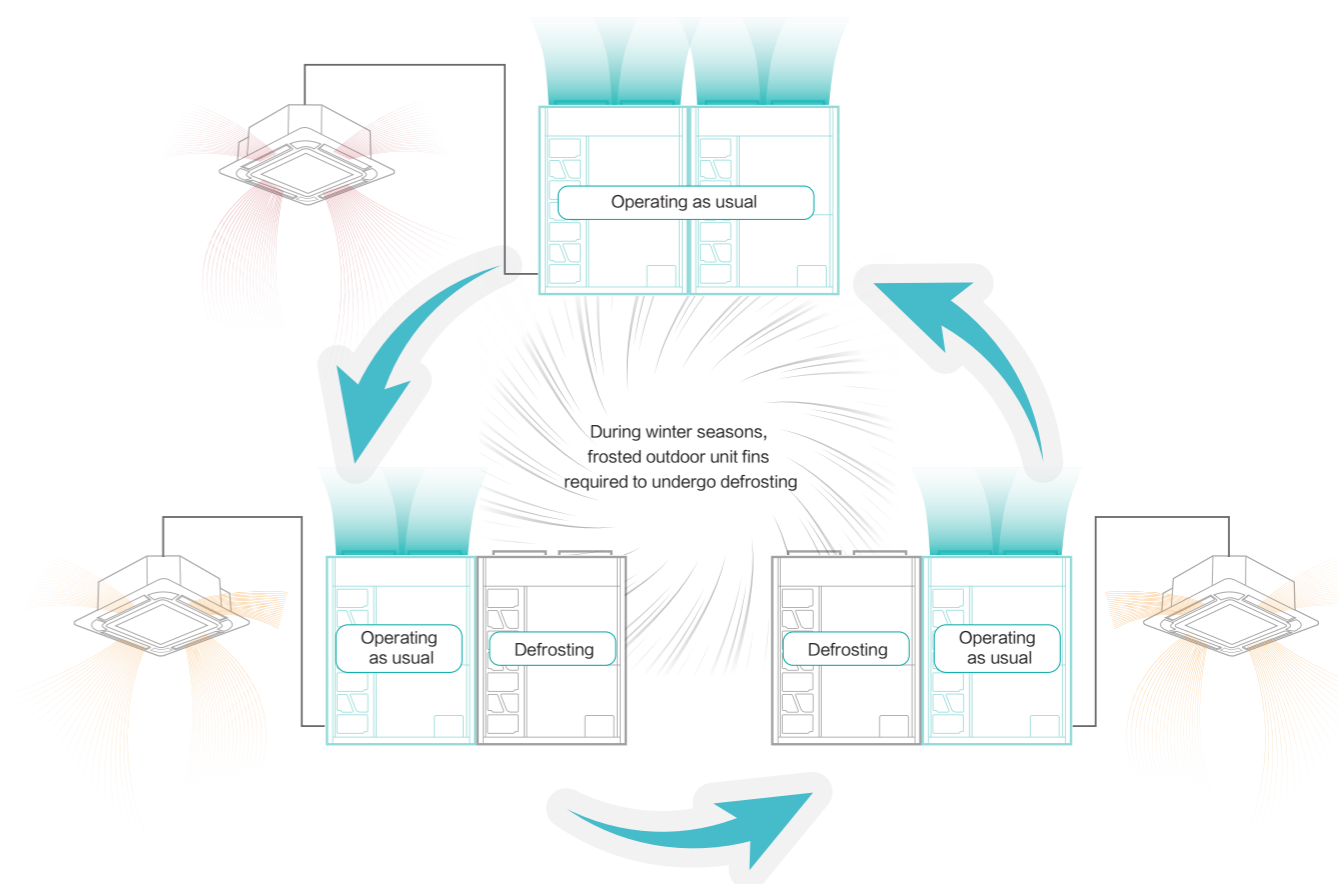
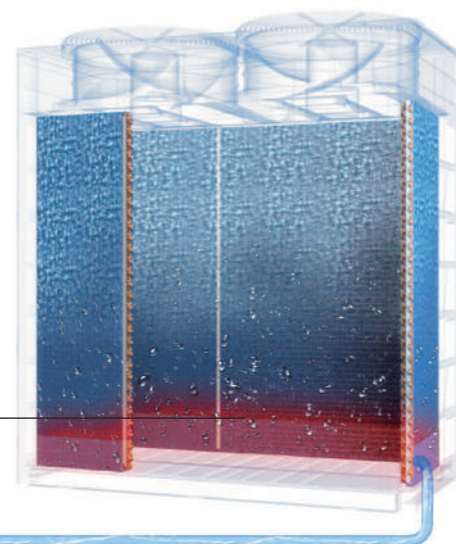

Note

Only available for module combinations of Hi-FLEXi S Heat Recovery.

Steady Air Discharge

High efficiency aerodynamic axial fan

The propeller bearing which acts as the joint connecting the propeller and motor are specially treated with anti-rain corrosion treatment and propeller made of fiber glass composite is now better corrosion resistance. Fan blades are aerodynamically designed to reduce energy wastage in converting power consumed to unnecessary noise energy, reserving the energy to improve on flowrate performance and static pressure. Integration with brushless DC fan motor further improves the efficiency and reduces noise of the propeller structure.

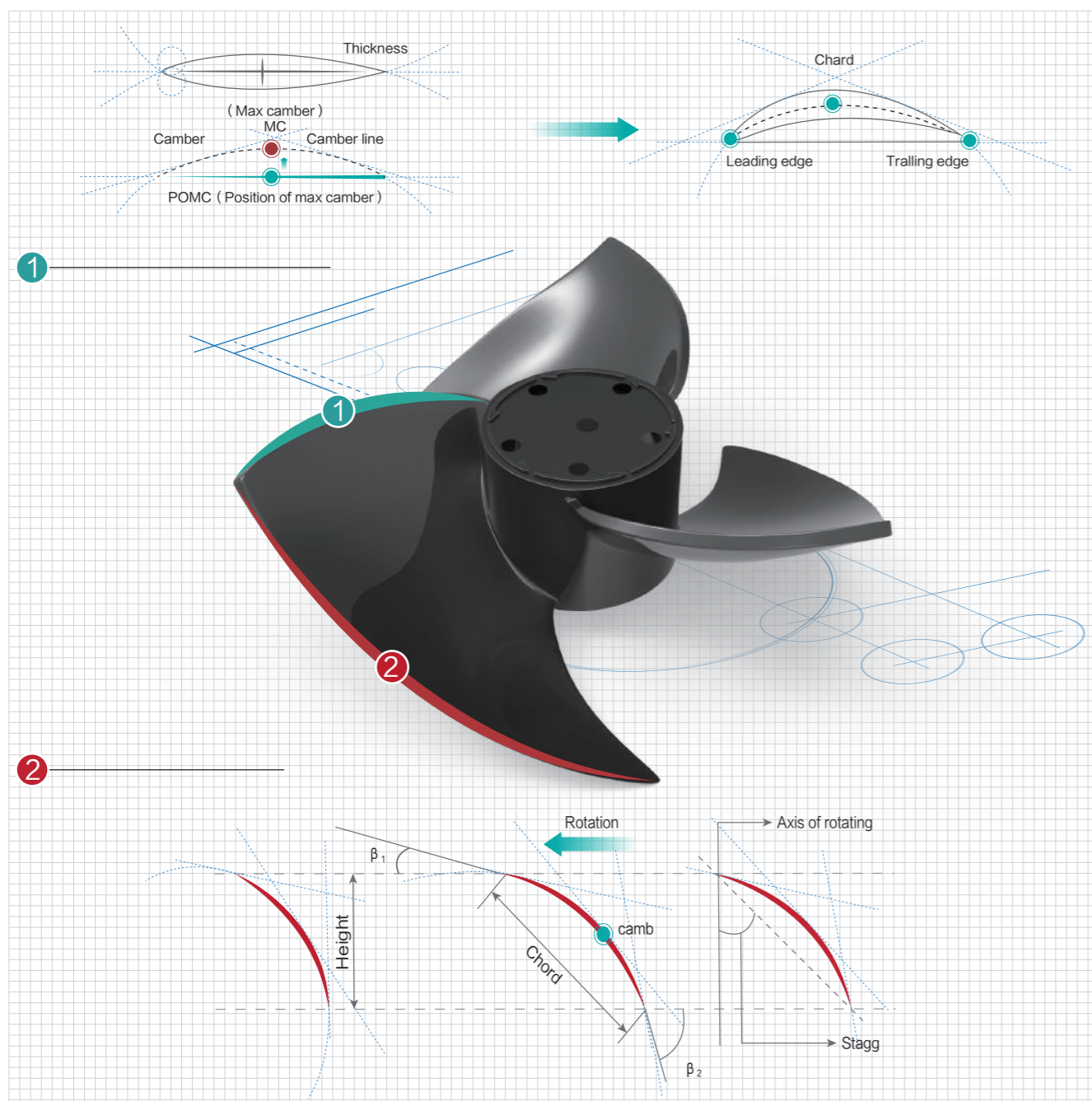

Stepless-smooth fan speed control

Inverter fan motors are now commonly used, where efficiency increase by 40%. Whereas in Hisense VRF, brushless DC fan motors are used, as it could further reduce power consumption and noise production than normal inverter motors.

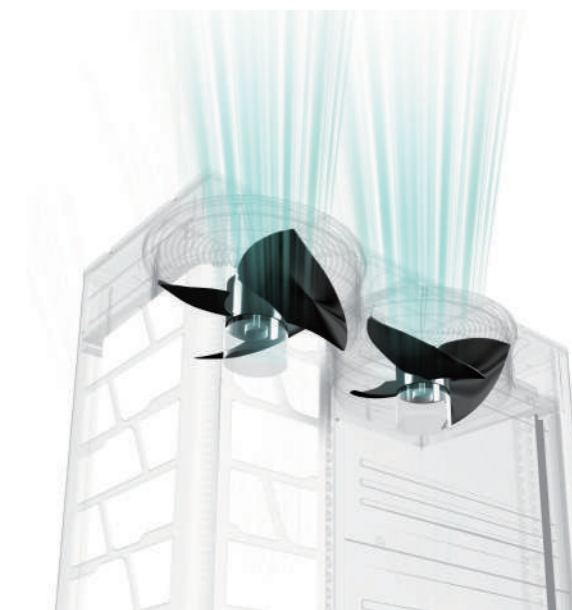

Efficient axial fan

Auto Refrigerant Temperature Control (ART)

Hisense VRF system featured with ART technology can meet the indoor loads more accurately at a higher efficiency. The system adjusts the evaporating temperature (E_t) according to actual indoor loads automatically in a wide range. The E_t is raised to minimize the difference with the condensing temperature when the air-conditioning load is low, thus further improving the energy efficiency.

Features:

1. Energy efficiency is improved without sacrificing comfort.
2. ART is particularly efficient under low-load operation.
3. The initial evaporation temperature can be adjusted between 2–11°C, which is the widest in the market.
4. Realize rapid cooling with lower evaporating temperature.
5. Avoiding cold draft with higher evaporating temperature.

$E_t = E_{to} + K$
 E_t : Evaporation temperature
 E_{to} : The initial evaporation temperature
 ΔT : The temperature difference between air inlet and the setting temperature

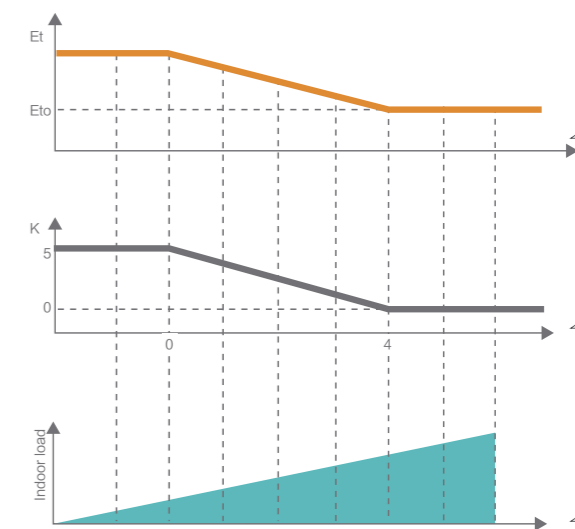

Hisense VRF

COMFORT

Smart Air Supply

Lower Noise

Clean Fresh Air

Auto Refrigerant Temperature Control (ART)

VIP Mode

AIR
CONDITIONING
SOLUTION

Smart Air Supply

Precise temperature control

There are multiple temperature sensors equipped in the system, which will be very helpful to judge the indoor load more accurately. Also the 2000-step EEV is specially adopted to ensure precise refrigerant flow adjustment according to the actual load of indoor units, achieving a more comfortable indoor environment with small temperature fluctuation.

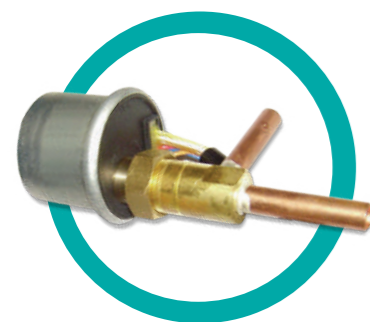

2000-step EEV

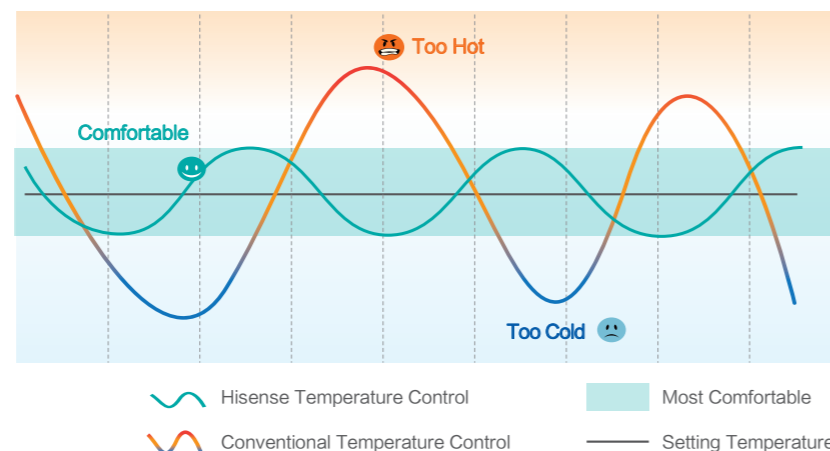

3D air-flow panel

The 3D air-flow panel with luxurious appearance is available for the low-height ceiling ducted indoor units (optional). The 3D airflow panel can offer even airflow and wide airflow coverage to keep every corners of your room cool or warm. It also has three wind setting, normal mode, 3D mode and super long distance mode, flexible for you choice.

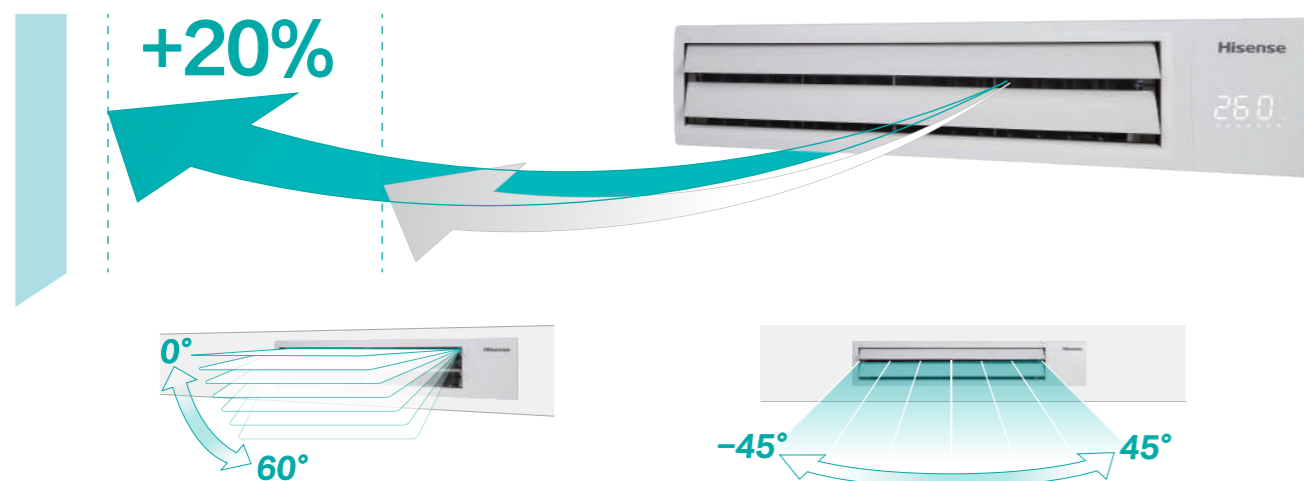

Hi-motion (optional)

Hi-Motion works as an independent human sensor and can be installed separately from indoor unit. It can detect the human activities indoors to provide comfort and energy savings.

1. Automatically stops the unit when no one is in the room in order to realize energy saving.
2. Adjusting the setting temperature and air flow according to the actual human activity.

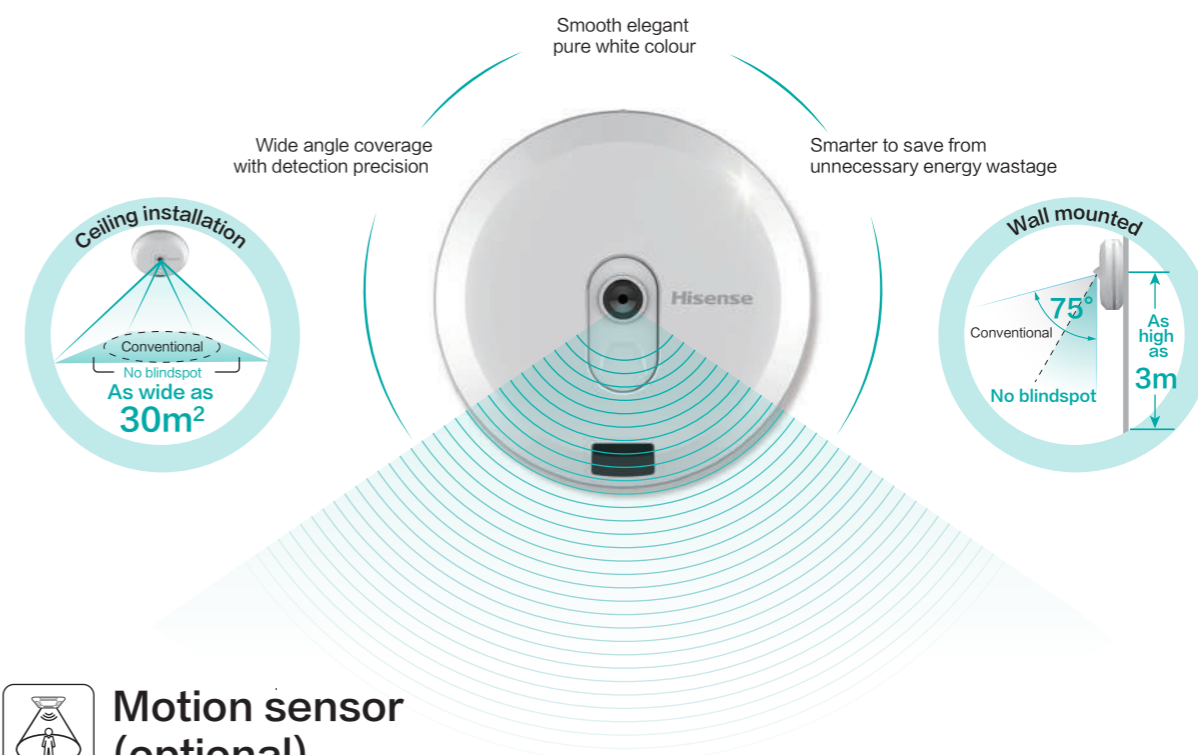

Motion sensor (optional)

Motion Sensor, assembled in the panel of 4-Way Cassette and Mini 4-Way Cassette, can provide a more comfortable environment, and achieve efficient and energy-saving operation of the unit at the same time.

1. With the sensor, indoor unit can ON or OFF automatically when people enter or leave the room.
2. The people location can be detected by the sensor automatically, and the air flow direction can be set to blow directly or to avoid blowing at people as they like.
3. The setting temperature can be changed automatically by detecting the number of people changing.

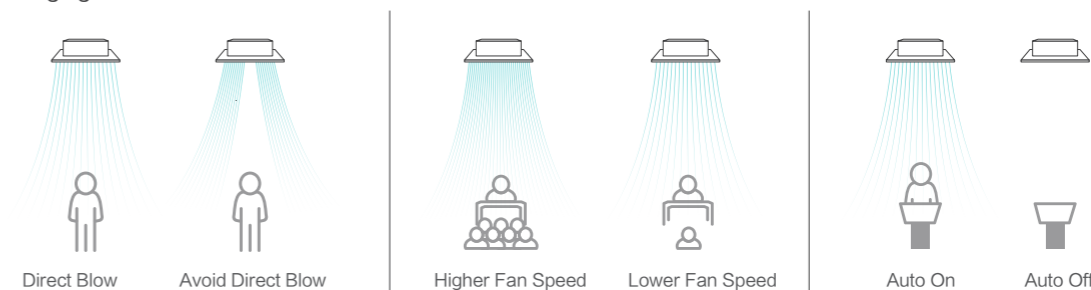

Lower Noise

Lower noise for indoor units

Hisense VRF offers indoor units with sound pressure level as low as 21dB(A), perfectly blending into library, auditorium and hospital rooms where require sound level lower than 25dB(A).

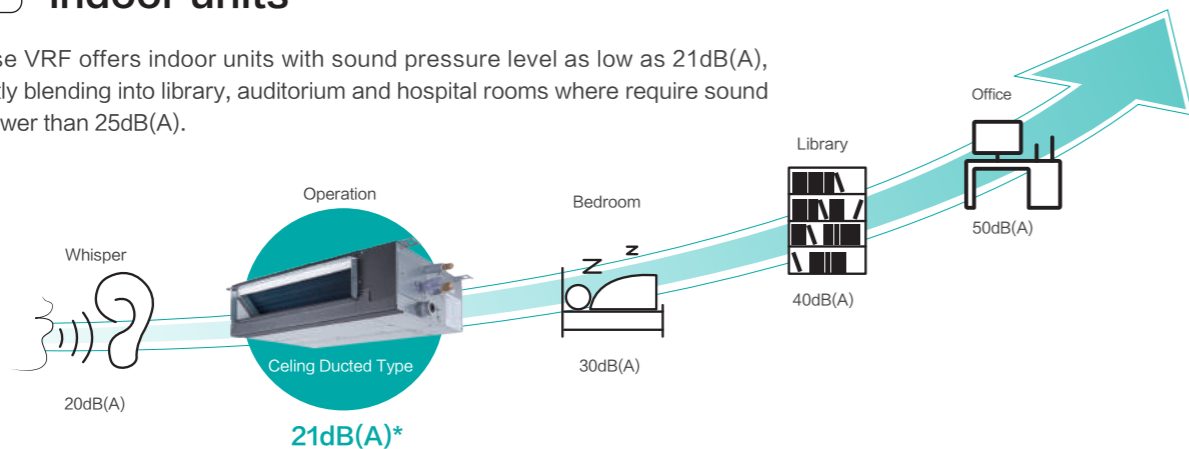

Note

*The DC ceiling ducted type (AVE-05HJFDL) can achieve the 21dB(A) under the standard test condition.

Outdoor unit noise control

Auto night quiet mode

When outdoor conditions call for special low noise requirements, like in cases where outdoor units are installed in indoor equipment rooms with poor soundproof walls or continuous night operating conditions. The night mode reduces sound pressure levels upto 30% routinely with flexible time intervals to meet different customer needs.

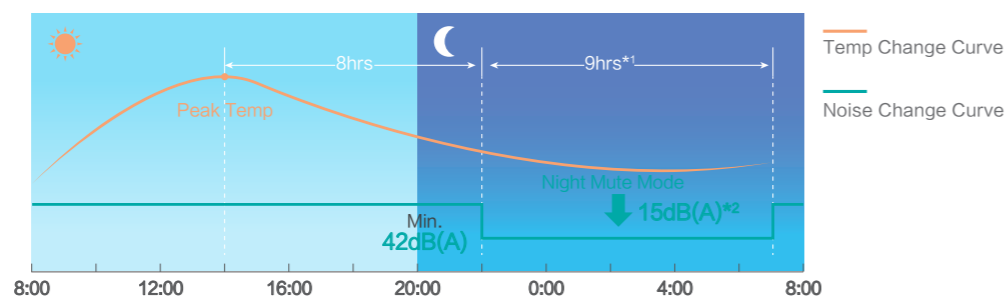

Note

*1: The night mute mode can last for 8hrs, 9hrs or 10hrs according to the setting.

*2: Take the unit AWWT-96HKFSEA of S mavo+ series as an example.

Low noise mode

Low noise mode can be set by operating the DIP in the PCB. There are multiple levels by set different frequencies of compressor and fan motor speed. What's more, the low noise mode can be achieved by external input signal. The noise can be reduced by up to 14dB(A).

90s Rapid Heating Start-up

To keep you comfortable and cozy as fast as possible, Hisense VRF starts supplying warm air so rapidly with only just 90s reaching a 100% capacity output. Besides, even in extreme weather condition like -15°C outdoor temperature, Hisense VRF performance is tested with persisting capability to supply 40°C or higher warm air within 7 minutes.

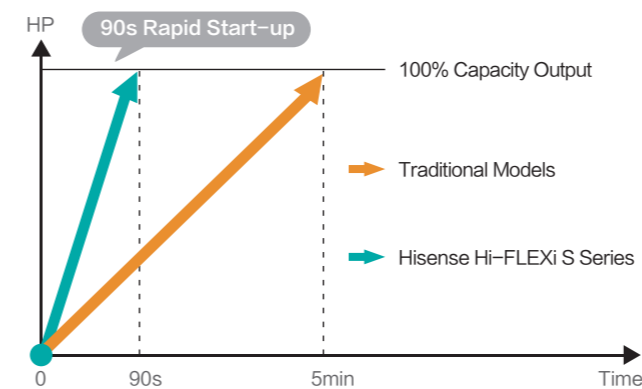

*Taking 66HP as an example

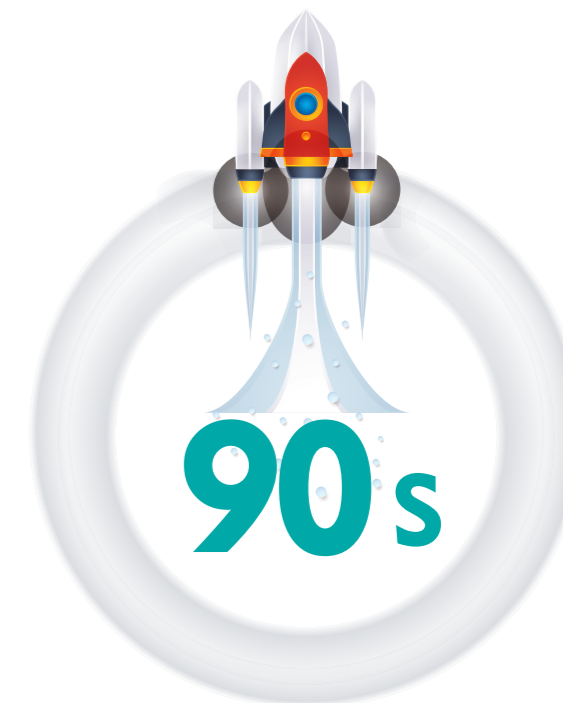

VIP Mode

Hisense VRF offers VIP mode to give priority to the specific room, keeping them comfortable and satisfied as fast as possible and 5 indoor units can be set as VIP mode at the same time. Such function is exclusively practical for hotel application, where AC unit in the presidential suite is often set to VIP mode.



Clean Fresh Air

AirPure

Hisense VRF indoor unit equipped with AirPure kit can release lots of negative ions, about 20 million pcs/cc. These negative ions are carried throughout the room with air-conditioned air flow whereby obtaining air conditioning and air purification simultaneously. With the AirPure kit, the indoor unit has got the Tick Mark certification which is an authentication for air-conditioning sterilization products.

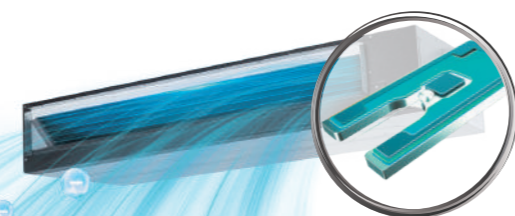

AirPure



*Take AVE-09HCFRL as the test sample.



Note

4-way Cassette, Mini 4-way Cassette, Console, Ceiling Ducted can be equipped with the AirPure kit (optional).

Self-cleaning function

Featured with self-cleaning technology, the evaporator can be self-cleaned automatically, preventing the dust and potentially harmful substances from accumulating on the surface of the heat exchanger. Thus the air blown from the air conditioner is clean and healthy.

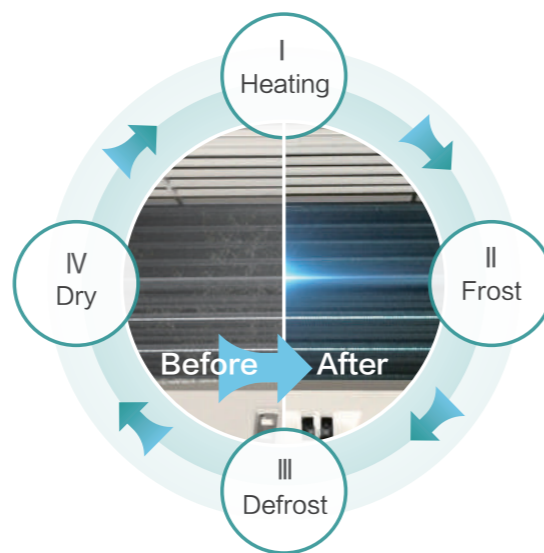

4 processes for deep cleaning

Note

The self-cleaning function is available in the wall mounted unit and DC high ESP ceiling ducted unit(AVD-07~AVD-54).

Humidity sensor (optional)

To keep up with the indoor quality requirements, Hisense VRF offers auto dehumidification function and it can be achieved by choosing a humidity sensor, and the control range is from 35% to 90%.

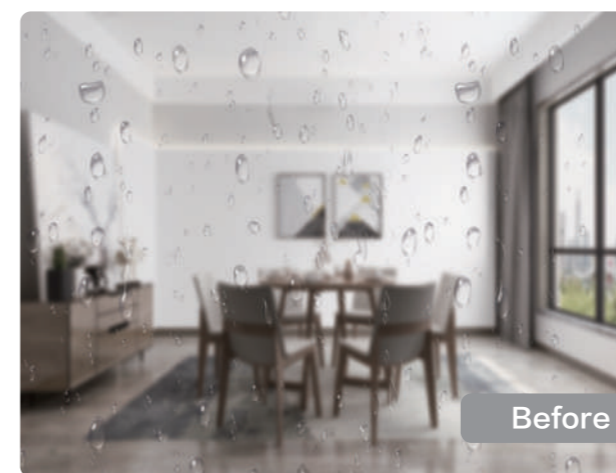

Fresh air intake

New Hisense VRF indoor units are now infused with a fresh air duct opening for 10% free fresh air introductory directly from outdoor air, creating a comfortable and health environment.

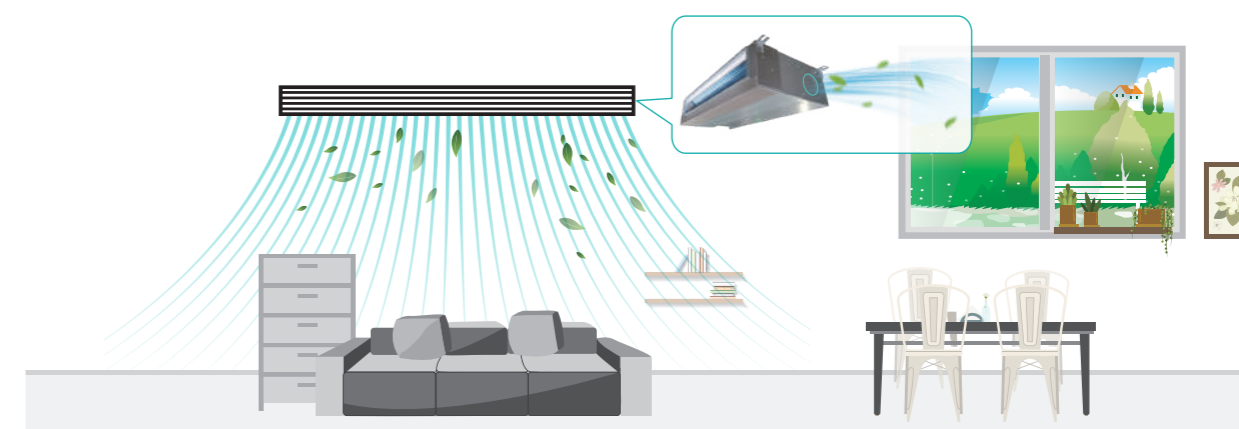

FLEXIBILITY



Design Flexibility

Installation Convenience

Service & Maintenance Simplicity

Design Flexibility

Interlocking solution using dry contact

3rd party thermostats can be used to control the air conditioner in a room by using the dry contact interface. Indoor units can be interlocked with various types of input signal such as key-card, window contact signal, smoke alarm signal and so on.

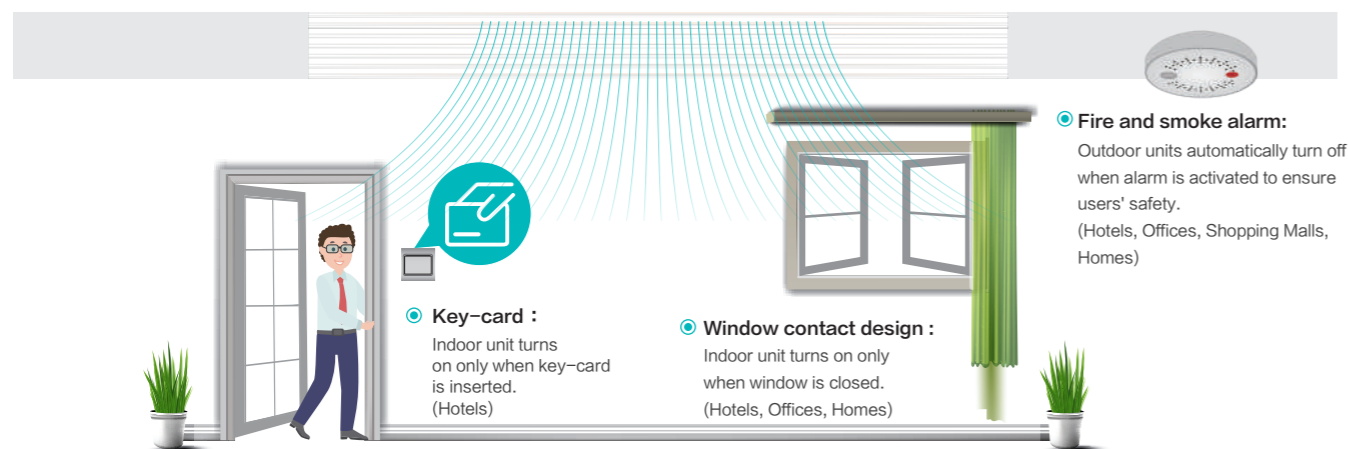

Adaptive fan static pressure technology

External static pressure is essential to determine the air discharge and duct connection distance. Hisense VRF's outdoor unit external static pressure is reachable upto 110Pa compare to the conventional 80Pa. Allowing longer ducting connection for better air discharge when are installed in the equipment platform that is not easy to exhaust.

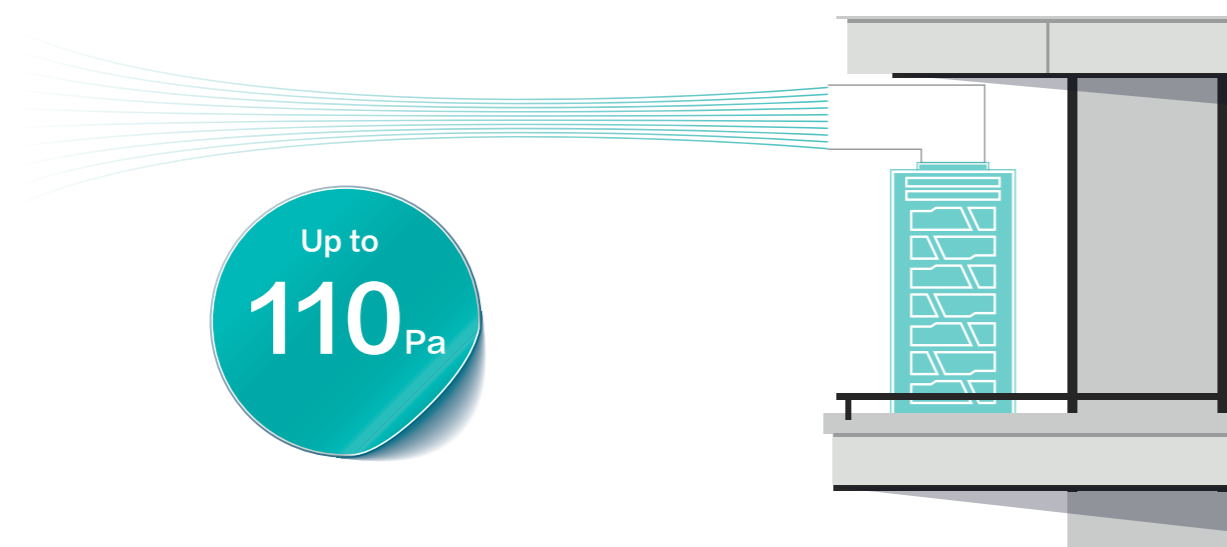

Note The initial setting is 80Pa. Can be set to 110Pa from the PCB on site.

Larger capacity, minimizing footprint area

Hisense VRF outdoor units now possess larger capacity per single module unit. Reducing the installation floor space significantly also eliminates the necessity of modules for bigger capacity. Despite the beneficial space saving properties, same goes to the unit's weight per capacity too. Hence, offering more design and installation flexibility even in limited spaces.

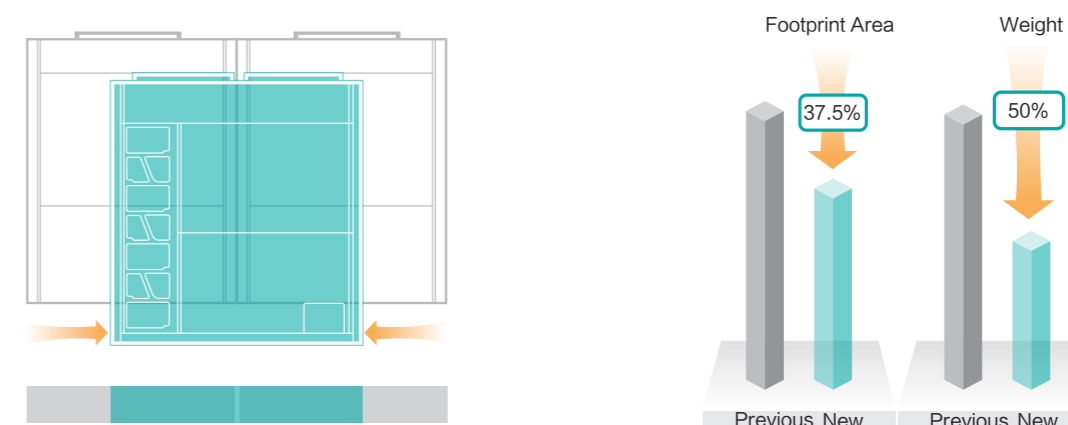

All in one renewable energy solution

Hisense VRF heat recovery series offers an ultimate solution to satisfy heating and cooling, domestic hot water supply, floor/wall/ceiling cooling and heating simultaneously. The heat recovery system is also compatible with any auxiliary heaters like solar, electric heater and gas boiler to supply additional energy to the system in unfavorable conditions.

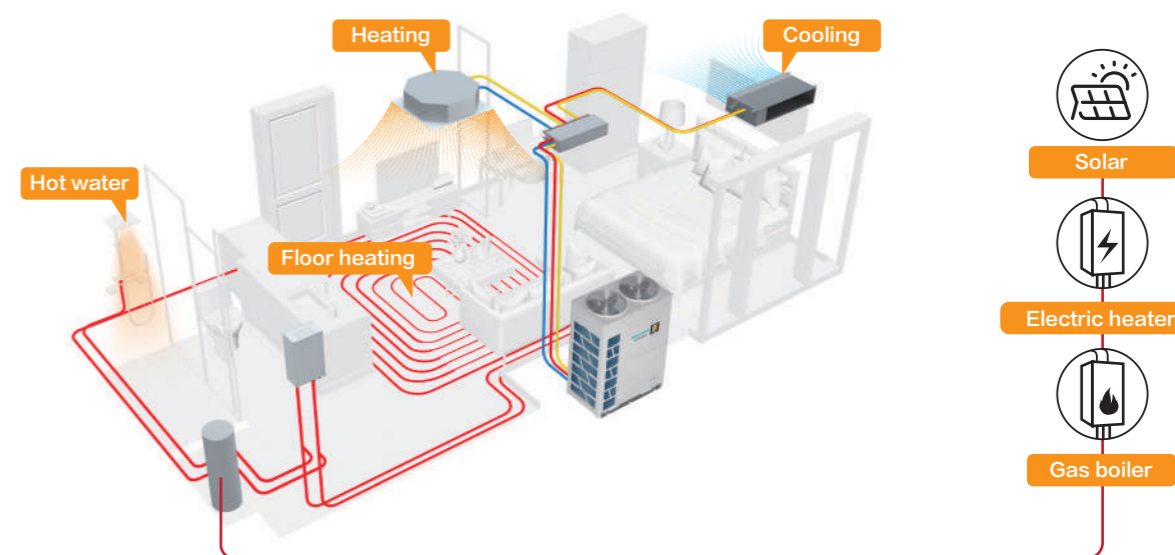

Installation Convenience

Compact and light-weight

With larger capacity per unit, Hisense VRF outdoor units are more compact in size with the largest capacity of 28HP single module, leading capacity of a single module in the market. Compact yet reduced overall weight makes transportation much convenient and even fit into elevators.



One-touch test run

Test run is one of the essential part in testing and commissioning to make sure the HVAC system in a building works steadily and safely before hand over or soft opening. To make test run as simple as possible, Hisense VRF systems are capable to conduct test runs with just a button away wherever installers are, both indoors and outdoors.

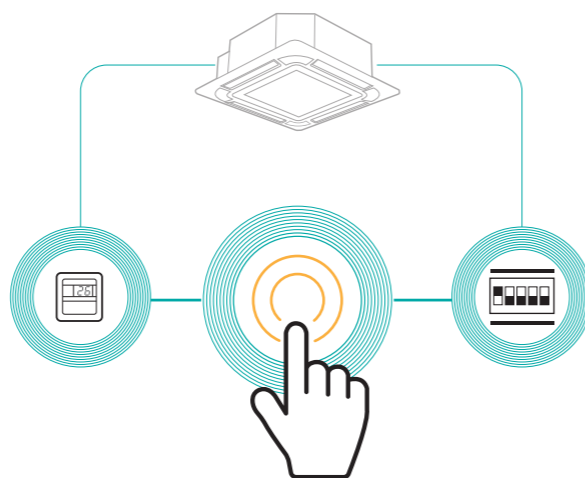

AUTO Intelligent matching IDUs

Match all kinds of hisense indoor units. If each air deflector can be controlled independently, the key will light. On the contrary, the key will dim and you can not click.

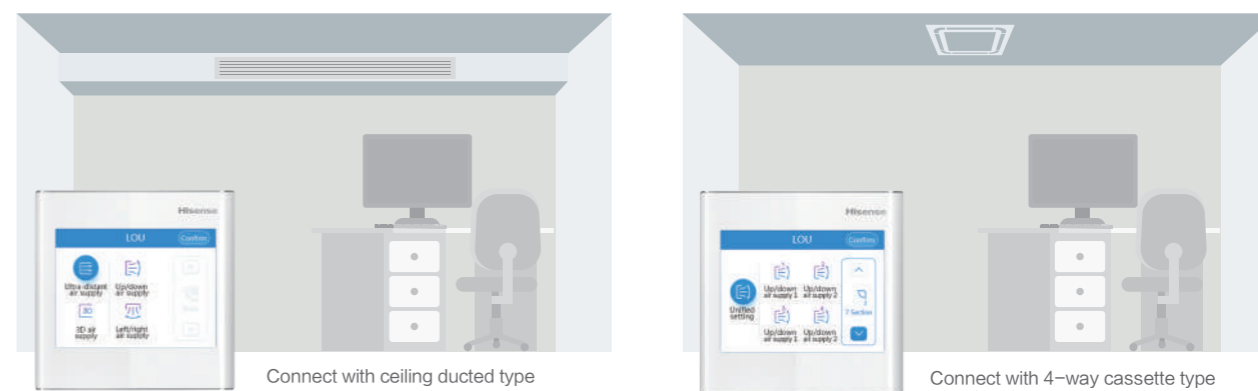

One-touch refrigerant recycle

Hisense VRF has one-touch refrigerant recycle function. Just with a press of the button on the PCB, the refrigerant can be recycled directly, it is very helpful and convenient when the indoor units or the compressor are under repair.



Scan the QR code to view the detailed introduction

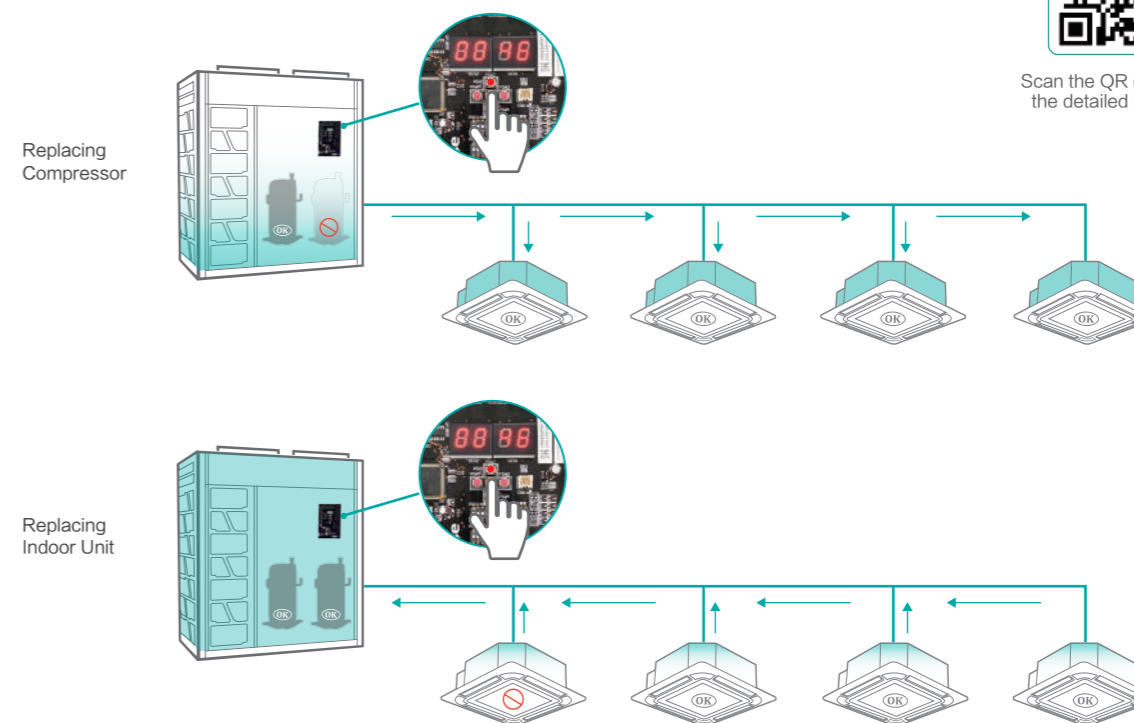

Mistake impossible communication connection

Communication line connections between outdoor unit to indoor units might be confusing when comes to long cables from the outdoors to the indoors and vice versa. It is often incorrectly connected and caused various errors affecting the end user's comfort levels. Despite of Hisense VRF's simple wiring connection ports, the outdoor unit itself could also check on the connections and display warnings when the connections are improper.

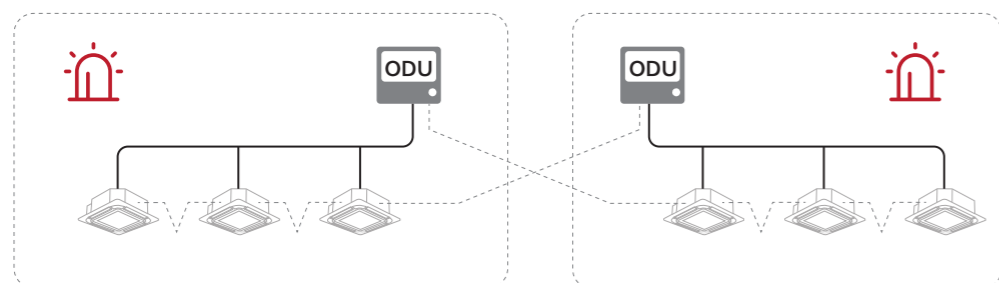

Indoor units from different systems are connected to the incorrect outdoor unit, alarm codes flashes out warning installers to make proper corrections.

Service & Maintenance Simplicity

Plug and play automatic addressing

The necessity to address each units could be so troublesome hence why not letting the software to auto address each indoor units by default. Such function is very important in troubleshooting and fault diagnosis when only specific indoor units malfunctioned. It is as easy as plug and play, connect the indoor units to the outdoor units and indoor unit addresses are completely set automatically.

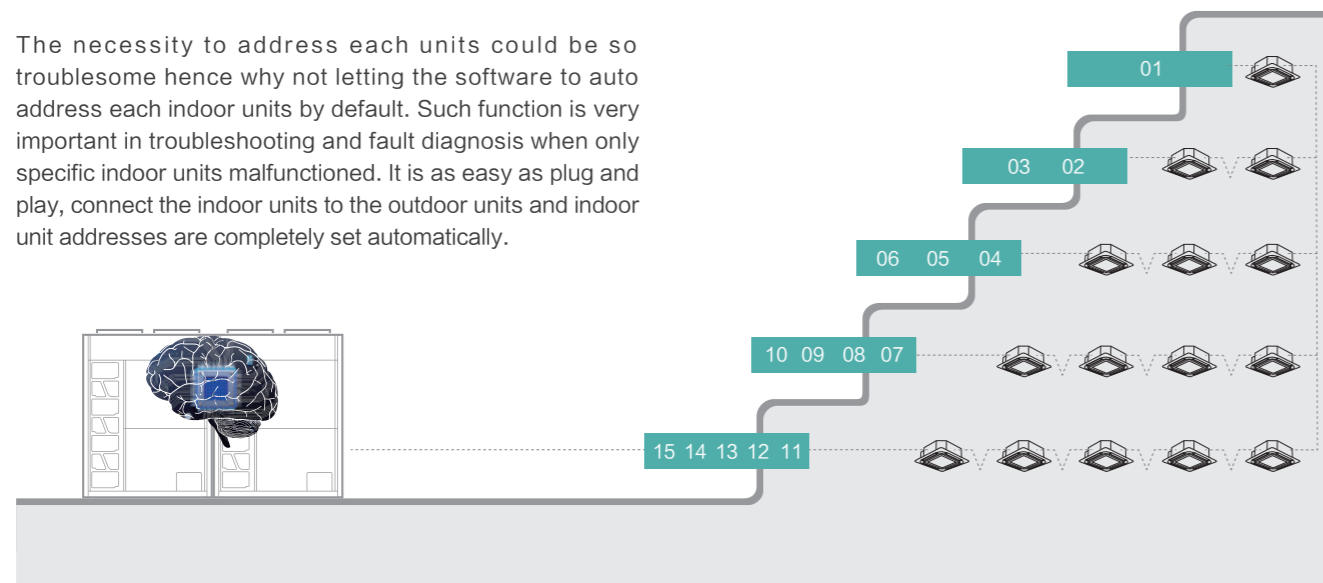

Safe and convenient system management

The new outdoor units are equipped with a service window on top of the electrical box protection panel for easy access to parameters checking and maintenance manipulation safely without exposing to high voltage segments of the electric box. With the new service windows, press switch buttons, DIP switches and the 7 segment LED operation are made safer and more convenient to operate.



Separated mechanical & electrical compartment

The outdoor unit's mechanical and electrical segments is now designed and optimized repositioned separately for a more organized maintenance. The electrical and electronics are placed on top of the compressors and accumulator to meet the practical law of center of gravity, hence minimizing toppling accidents and unnecessary vibration produced during operation. Besides, it also maximizes the heat dissipation of electrical box to keep the electrical in a stable temperature by maximizing airflow passed by.

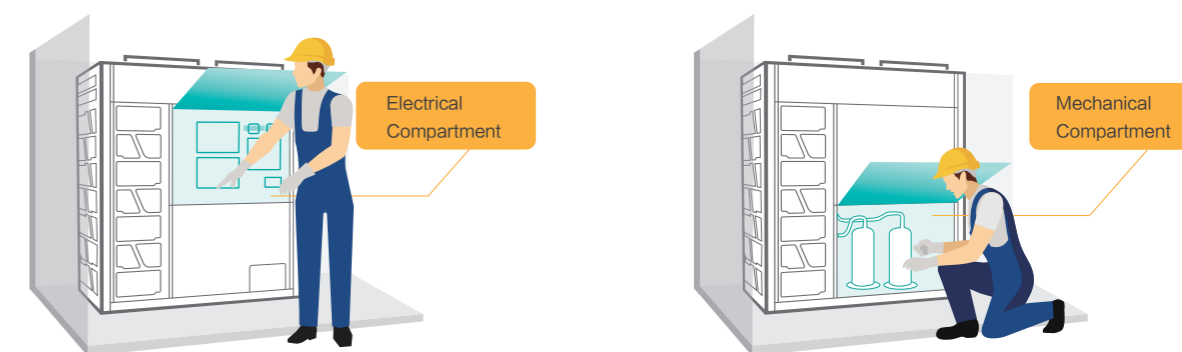

Accurate intelligent system diagnosis

Exclusive Hi-Checker is a super intelligent service tool for system diagnosis, which can provides easy access to service parameters. Detail operation status and recent error history can be checked and analyzed by using Hi-Checker.

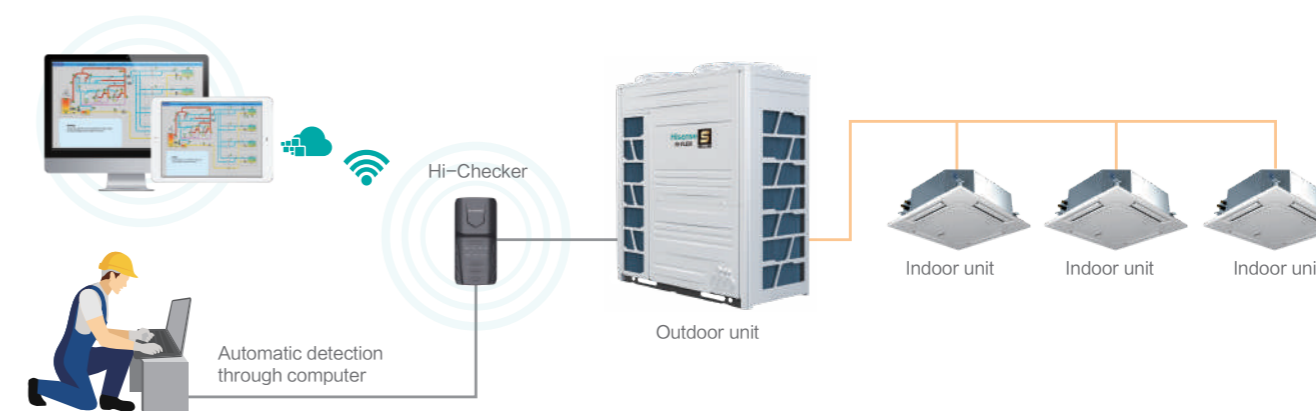

Hi-FLEXi S Heat Recovery



All in One Renewable Energy Solution

With S heat recovery series, cooling and heating of air can be realised simultaneously including water. During summer, it serves cool indoor rooms and warm water supply for night showers. With the same system, floor heating and fan coil unit heating and cooling can be done during season transition periods.

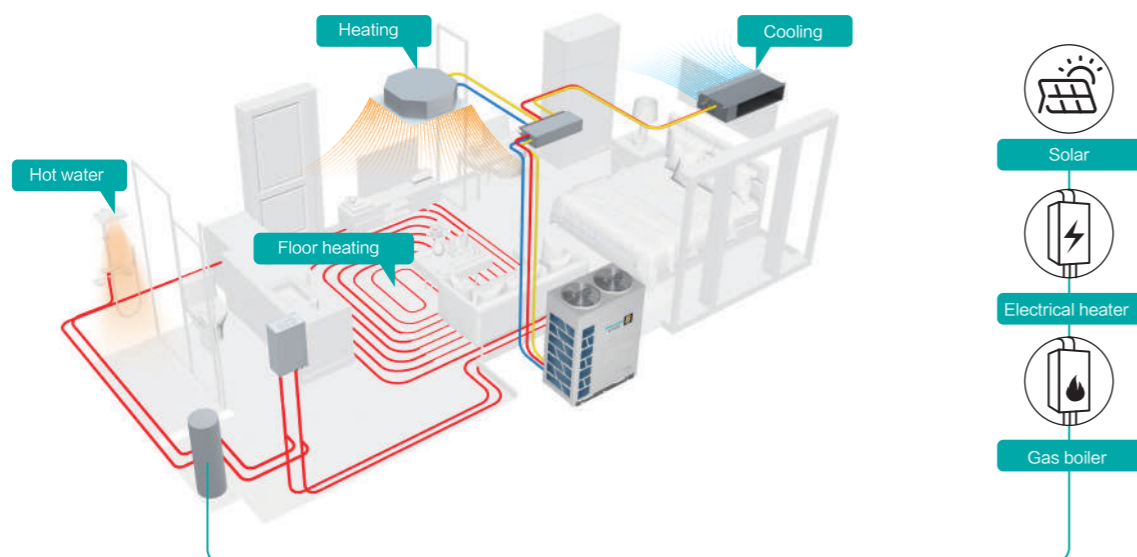

200% Connection Ratio

The powerful S heat recovery series outdoor units are connectable to indoor units up to 2 times of its own capacity with ratio of 200% for a more efficient and cost saving system.



External Static Pressure

External static pressure is reachable up to 110Pa, allowing better air discharge when are installed indoors with ducting or even outdoors in poor air ventilation spaces.

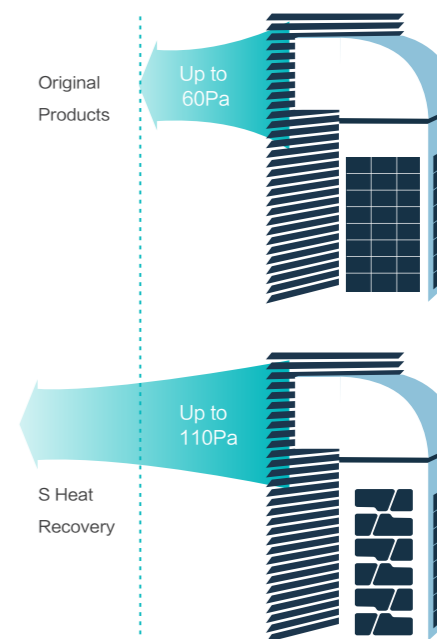

Piping Length

With extra long pipe, the height difference between the indoor unit and outdoor unit is up to 90 meters*, which makes installation more flexible.

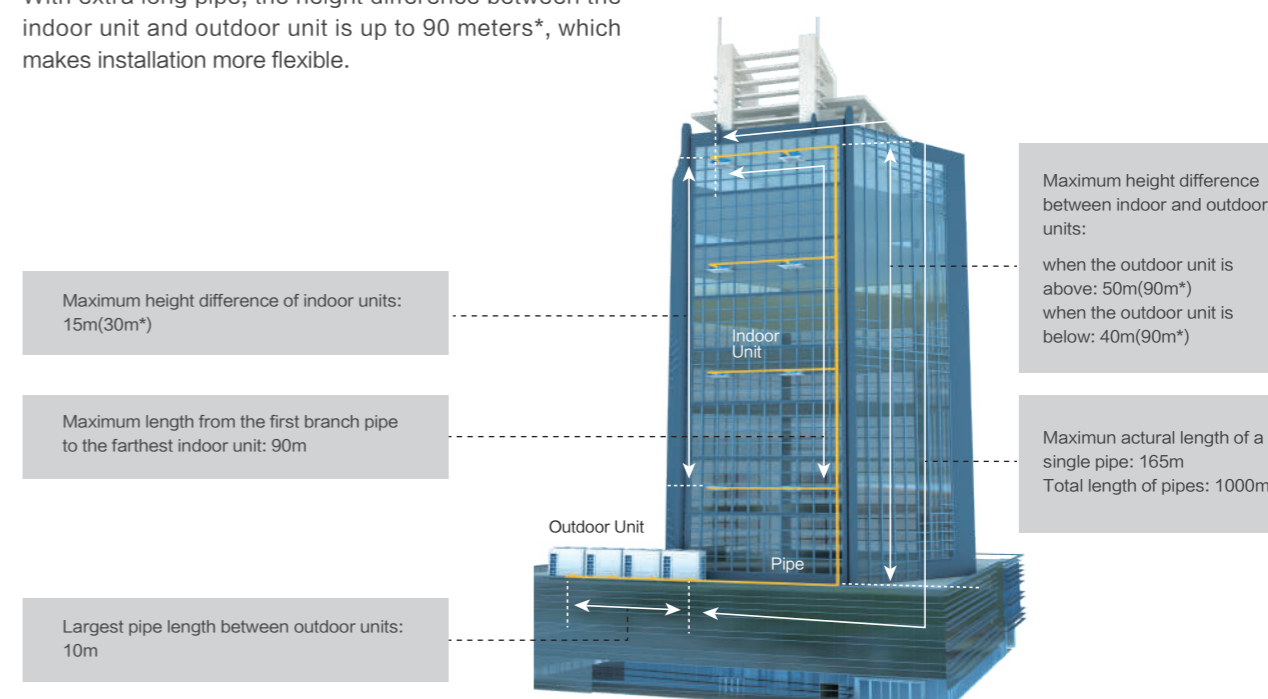

*Note: For detailed information, please contact Hisense's technical staff.

New Upgraded Switch Box

Switch box defies the complicated piping of 3pipe heat recovery systems and simplifies the system with lesser connections and piping including refrigerant and condensate piping. Now with larger capacity up to 85kW for larger systems and increased up to 16 branch ports for more indoor units connections.

Heating Domination Mode

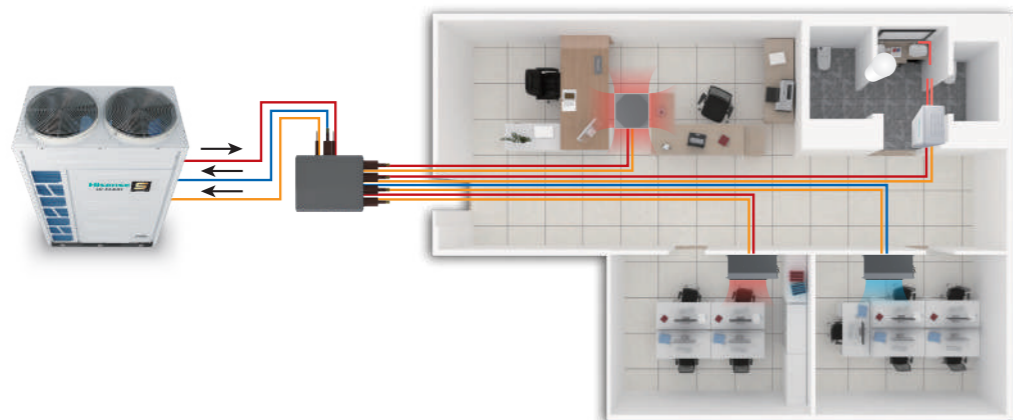

3 Pipes Without Switch Box

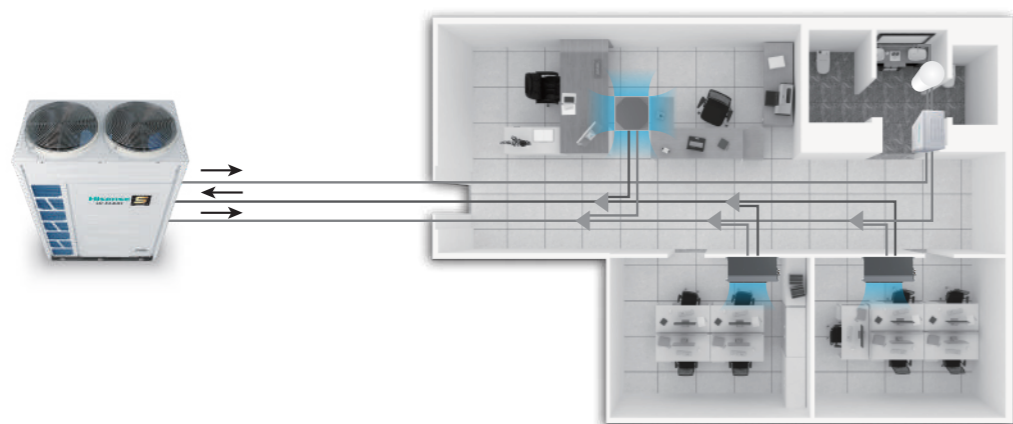

Dual 20RT EEV

Compared with conventional 10RT EEV with 480 steps, dual 20RT EEV with 3000pls can better reduce pressure loss and improve performance.

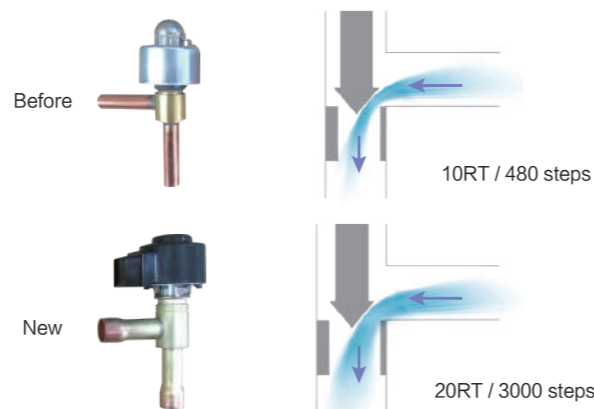
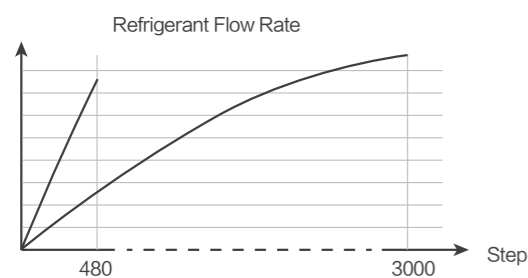

Hi-FLEXi S Heat Recovery



HP		8HP	10HP	12HP	14HP	16HP	18HP
Model	Model	AVWT-76FKFSA	AVWT-96FKFSA	AVWT-114FKFSA	AVWT-136FKFSA	AVWT-154FKFSA	AVWT-170FKFSA
	Modules	—	—	—	—	—	—
Power Supply		AC 3φ, 380-415V/50/60Hz					
Cooling	Capacity	kW	22.4	28.0	33.5	40.0	50.0
		kBtu/h	76.4	95.5	114.3	136.5	153.5
	Power Input	kW	4.87	6.75	8.09	10.26	12.16
	EER	kW/kW	4.60	4.15	4.14	3.90	3.70
Heating	Capacity(Max/Nom)	kW	25.0 / 22.4	31.5 / 28.0	37.5 / 33.5	45.0 / 40.0	50.0 / 45.0
		kBtu/h	85.3 / 76.4	107.5 / 95.5	128.0 / 114.3	153.5 / 136.5	170.6 / 153.5
	Power Input(Max/Nom)	kW	5.20 / 4.36	6.77 / 5.63	9.17 / 7.70	10.82 / 8.89	12.14 / 10.32
	COP(Max)	kW/kW	4.81	4.65	4.09	4.16	4.12
Ventilation	Air Flow Rate	m³/min	183	183	183	200	200
	Fan Quantity		1	1	1	2	2
	Static Pressure	Pa	110	110	110	110	110
Sound	Sound Pressure Level	dB(A)	59	60	62	62	62
	Type		Enhanced Vapor Injection Scroll Compressor				
Compressor	Compressor Quantity	pcs	1	1	1	1	2
	Type		R410A				
Refrigerant	Pre-charged Quantity	kg	5.60	5.90	6.00	8.80	9.20
	Net Weight	kg	226	227	246	289	290
Weight	Gross Weight	kg	246	247	266	311	349
	External(HxWxD)	mm	1730x950x750	1730x950x750	1730x950x750	1730x1210x750	1730x1210x750
Dimensions	Packing(HxWxD)	mm	1930x1015x790	1930x1015x790	1930x1015x790	1930x1275x790	1930x1275x790
	Cabinet Color		Ivory White	Ivory White	Ivory White	Ivory White	Ivory White
Heat Recovery Operation System	Low Pressure Gas Line	mm(in.)	φ 19.05(3/4)	φ 22.20(7/8)	φ 25.40(1)	φ 25.40(1)	φ 28.60(1-1/8)
	High/Low Pressure Gas Line	mm(in.)	φ 15.88(5/8)	φ 19.05(3/4)	φ 22.2(7/8)	φ 22.2(7/8)	φ 22.2(7/8)
	Liquid Line	mm(in.)	φ 9.53(3/8)	φ 9.53(3/8)	φ 12.70(1/2)	φ 12.70(1/2)	φ 15.88(5/8)
Heat Pump Operation System	Gas Line	mm(in.)	φ 19.05(3/4)	φ 22.20(7/8)	φ 25.40(1)	φ 25.40(1)	φ 28.60(1-1/8)
	Liquid Line	mm(in.)	φ 9.53(3/8)	φ 9.53(3/8)	φ 12.70(1/2)	φ 12.70(1/2)	φ 15.88(5/8)
Connectable Indoor Units	Quantity	pcs	13	16	19	23	29
	Total Capacity		200%*1	200%*1	200%*1	200%*1	200%*1
Piping Design	Height Difference Between ODU and IDU	m(above)	50(90°)	50(90°)	50(90°)	50(90°)	50(90°)
		m(below)	40(90°)	40(90°)	40(90°)	40(90°)	40(90°)
	Height Difference Between IDUs	m	15(30°)	15(30°)	15(30°)	15(30°)	15(30°)
	Max. Piping Length	m	165	165	165	165	165
Operation Range	Cooling	DB	-10°C-52°C	-10°C-52°C	-10°C-52°C	-10°C-52°C	-10°C-52°C
	Heating	WB	-25°C-16.5°C	-25°C-16.5°C	-25°C-16.5°C	-25°C-16.5°C	-25°C-16.5°C

Hi-FLEXi S Heat Recovery



HP		20HP	22HP	24HP	26HP	28HP
Model	Model	AVWT-190FKFSA	AVWT-212FKFSA	AVWT-232FKFSA	AVWT-250FKFSA	AVWT-272FKFSA
	Modules	—	—	—	—	—
Power Supply		AC 3Φ, 380-415V/50/60Hz				
Cooling	Capacity	kW 56.0	61.5	68.0	72.5	80.0
		kBtu/h 191.1	209.8	232.0	247.4	273.0
	Power Input	kW 15.60	18.04	20.61	21.90	24.24
	EER	kW/kW 3.59	3.41	3.30	3.31	3.30
Heating	Capacity(Max/Nom)	kW 63.0 / 56.0	69.0 / 61.5	75.0 / 68.0	80.0 / 72.5	90.0 / 80.0
		kBtu/h 215.0 / 191.1	235.4 / 209.8	255.9 / 232.0	273.0 / 247.4	307.1 / 273.0
	Power Input(Max/Nom)	kW 16.54 / 13.56	18.80 / 15.89	21.43 / 18.38	22.35 / 19.23	26.01 / 21.92
	COP(Max)	kW/kW 3.81	3.67	3.50	3.58	3.46
Ventilation	Air Flow Rate	m ³ /min 267	296	296	350	350
	Fan Quantity	2	2	2	2	2
	Static Pressure	Pa 110	110	110	110	110
Sound	Sound Pressure Level	dB(A) 63	64	66	67	67
Compressor	Type	Enhanced Vapor Injection Scroll Compressor				
	Compressor Quantity	2	2	2	2	2
Refrigerant	Type	R410A				
	Pre-charged Quantity	kg 9.80	10.60	10.60	11.50	11.50
Weight	Net Weight	kg 369	377	378	400	401
	Gross Weight	kg 393	401	402	426	427
Dimensions	External(HxWxD)	mm 1730x1350x750	1730x1350x750	1730x1350x750	1730x1600x750	1730x1600x750
	Packing(HxWxD)	mm 1930x1420x790	1930x1420x790	1930x1420x790	1930x1665x790	1930x1665x790
Cabinet Color		Ivory White				
Heat Recovery Operation System	Low Pressure Gas Line	mm(in.) Φ28.60(1-1/8)	Φ28.60(1-1/8)	Φ28.60(1-1/8)	Φ31.75(1-1/4)	Φ31.75(1-1/4)
	High/Low Pressure Gas Line	mm(in.) Φ22.2(7/8)	Φ25.4(1)	Φ25.4(1)	Φ25.4(1)	Φ28.6(1-1/8)
	Liquid Line	mm(in.) Φ15.88(5/8)	Φ15.88(5/8)	Φ15.88(5/8)	Φ19.05(3/4)	Φ19.05(3/4)
Heat Pump Operation System	Gas Line	mm(in.) Φ28.60(1-1/8)	Φ28.60(1-1/8)	Φ28.60(1-1/8)	Φ31.75(1-1/4)	Φ31.75(1-1/4)
	Liquid Line	mm(in.) Φ15.88(5/8)	Φ15.88(5/8)	Φ15.88(5/8)	Φ19.05(3/4)	Φ19.05(3/4)
Connectable Indoor Units	Quantity	pcs 33	36	40	43	47
	Total Capacity	— 200%*1	200%*1	200%*1	200%*1	200%*1
Piping Design	Height Difference Between ODU and IDU	m(above) 50(90*2)	50(90*2)	50(90*2)	50(90*2)	50(90*2)
		m(below) 40(90*2)	40(90*2)	40(90*2)	40(90*2)	40(90*2)
	Height Difference Between IDUs	m 15(30*2)	15(30*2)	15(30*2)	15(30*2)	15(30*2)
	Max. Piping Length	m 165	165	165	165	165
Operation Range	Cooling	DB -10°C-52°C	-10°C-52°C	-10°C-52°C	-10°C-52°C	-10°C-52°C
	Heating	WB -25°C-16.5°C	-25°C-16.5°C	-25°C-16.5°C	-25°C-16.5°C	-25°C-16.5°C

Hi-FLEXi S Heat Recovery



HP		30HP	32HP	34HP	36HP	38HP
Model	Model	AVWT-290FKFSA	AVWT-308FKFSA	AVWT-324FKFSA	AVWT-344FKFSA	AVWT-360FKFSA
	Modules	AVWT-136FKFSA AVWT-154FKFSA	AVWT-154FKFSA AVWT-154FKFSA	AVWT-154FKFSA AVWT-170FKFSA	AVWT-154FKFSA AVWT-190FKFSA	AVWT-170FKFSA AVWT-190FKFSA
Power Supply		AC 3Φ, 380-415V/50/60Hz				
Cooling	Capacity	kW 85.0	90.0	95.0	101.0	106.0
		kBtu/h 290.0	307.1	324.1	344.6	361.7
	Power Input	kW 22.41	24.32	26.20	27.75	29.64
	EER	kW/kW 3.79	3.70	3.63	3.64	3.58
Heating	Capacity(Max/Nom)	kW 95.0 / 85.0	100.0 / 90.0	106.0 / 95.0	113.0 / 101.0	119.0 / 106.0
		kBtu/h 324.1 / 290.0	341.2 / 307.1	361.7 / 324.1	385.6 / 344.6	406.0 / 361.7
	Power Input(Max/Nom)	kW 22.95 / 19.21	24.27 / 20.64	26.82 / 22.33	28.62 / 23.86	31.27 / 25.58
	COP(Max)	kW/kW 4.14	4.12	3.95	3.95	3.81
Ventilation	Air Flow Rate	m ³ /min 400	400	400	467	467
	Fan Quantity	4	4	4	4	4
	Static Pressure	Pa 110	110	110	110	110
Sound	Sound Pressure Level	dB(A) 67	67	67	67	67
Compressor	Type	Enhanced Vapor Injection Scroll Compressor				
	Compressor Quantity	2	2	3	3	4
Refrigerant	Type	R410A				
	Pre-charged Quantity	kg 8.80+8.80	8.80+8.80	8.80+9.20	8.80+9.80	9.20+9.80
Weight	Net Weight	kg 289+290	290+290	290+349	290+369	349+369
	Gross Weight	kg 311+312	312+312	312+371	312+393	371+393
Dimensions	External(HxWxD)	mm 1730x (1210+1210) x750	1730x (1210+1210) x750	1730x (1210+1210) x750	1730x (1210+1350) x750	1730x (1210+1350) x750
	Packing(HxWxD)	mm 1930x (1275+1275) x790	1930x (1275+1275) x790	1930x (1275+1275) x790	1930x (1275+1420) x790	1930x (1275+1420) x790
Cabinet Color		Ivory White				
Heat Recovery Operation System	Low Pressure Gas Line	mm(in.) Φ31.75(1-1/4)	Φ31.75(1-1/4)	Φ31.75(1-1/4)	Φ38.1(1-1/2)	Φ38.1(1-1/2)
	High/Low Pressure Gas Line	mm(in.) Φ28.6(1-1/8)	Φ28.6(1-1/8)	Φ28.6(1-1/8)	Φ28.6(1-1/8)	Φ31.75(1-1/4)
	Liquid Line	mm(in.) Φ19.05(3/4)	Φ19.05(3/4)	Φ19.05(3/4)	Φ19.05(3/4)	Φ19.05(3/4)
Heat Pump Operation System	Gas Line	mm(in.) Φ31.75(1-1/4)	Φ31.75(1-1/4)	Φ31.75(1-1/4)	Φ38.1(1-1/2)	Φ38.1(1-1/2)
	Liquid Line	mm(in.) Φ19.05(3/4)	Φ19.05(3/4)	Φ19.05(3/4)	Φ19.05(3/4)	Φ19.05(3/4)
Connectable Indoor Units	Quantity	pcs 50	53	56	59	64
	Total Capacity	— 200%*1	200%*1	200%*1	200%*1	200%*1
Piping Design	Height Difference Between ODU and IDU	m(above) 50(90*2)	50(90*2)	50(90*2)	50(90*2)	50(90*2)
		m(below) 40(90*2)	40(90*2)	40(90*2)	40(90*2)	40(90*2)
	Height Difference Between IDUs	m 15(30*2)	15(30*2)	15(30*2)	15(30*2)	15(30*2)
	Max. Piping Length	m 165	165	165	165	165
Operation Range	Cooling	DB -10°C-52°C	-10°C-52°C	-10°C-52°C	-10°C-52°C	-10°C-52°C
	Heating	WB -25°C-16.5°C	-25°C-16.5°C	-25°C-16.5°C	-25°C-16.5°C	-25°C-16.5°C

RELIABILITY

EFFICIENCY

COMFORT

FLEXIBILITY

OUTDOOR UNIT

INDOOR UNIT

CONTROL SYSTEM

ACCESSORY

Hi-FLEXi S Heat Recovery



HP		40HP	42HP	44HP	46HP	48HP
Model	Model	AVWT-380FKFSA	AVWT-402FKFSA	AVWT-422FKFSA	AVWT-444FKFSA	AVWT-464FKFSA
	Modules	AVWT-190FKFSA AVWT-190FKFSA	AVWT-170FKFSA AVWT-232FKFSA	AVWT-190FKFSA AVWT-232FKFSA	AVWT-212FKFSA AVWT-232FKFSA	AVWT-232FKFSA AVWT-232FKFSA
Power Supply		AC 3Φ, 380-415V/50/60Hz				
Cooling	Capacity	kW 112.0	118.0	124.0	129.5	136.0
		kBtu/h 382.1	402.6	423.1	441.9	464.0
	Power Input	kW 31.20	34.60	36.15	38.63	41.21
	EER	kW/kW 3.59	3.41	3.43	3.35	3.30
Heating	Capacity(Max/Nom)	kW 126.0 / 112.0	131.0 / 118.0	138.0 / 124.0	144.0 / 129.5	150.0 / 136.0
		kBtu/h 429.9 / 382.1	447.0 / 402.6	470.9 / 423.1	491.3 / 441.9	511.8 / 464.0
	Power Input(Max/Nom)	kW 33.07 / 27.12	36.12 / 30.30	37.92 / 31.85	40.21 / 34.25	42.86 / 36.76
	COP(Max)	kW/kW 3.81	3.63	3.64	3.58	3.50
Ventilation	Air Flow Rate	m³/min 534	496	563	592	592
	Fan Quantity	4	4	4	4	4
	Static Pressure	Pa 110	110	110	110	110
Sound	Sound Pressure Level	dB(A) 67	67	68	68	69
Compressor	Type	Enhanced Vapor Injection Scroll Compressor				
	Compressor Quantity	4	4	4	4	4
Refrigerant	Type	R410A				
	Pre-charged Quantity	kg 9.80+9.80	9.20+10.60	9.80+10.60	10.60+10.60	10.60+10.60
Weight	Net Weight	kg 369+369	349+378	369+378	377+378	378+378
	Gross Weight	kg 393+393	371+402	393+402	401+402	402+402
Dimensions	External(HxWxD)	mm (1350+1350) x750	(1210+1350) x750	(1350+1350) x750	(1350+1350) x750	(1350+1350) x750
		mm 1930x	1930x	1930x	1930x	1930x
	Packing(HxWxD)	mm (1420+1420) x790	(1275+1420) x790	(1420+1420) x790	(1420+1420) x790	(1420+1420) x790
		mm 1930x	1930x	1930x	1930x	1930x
Cabinet Color		Ivory White	Ivory White	Ivory White	Ivory White	Ivory White
Heat Recovery Operation System	Low Pressure Gas Line	mm(in.) Φ38.1(1-1/2)	Φ38.1(1-1/2)	Φ38.1(1-1/2)	Φ38.1(1-1/2)	Φ38.1(1-1/2)
	High/Low Pressure Gas Line	mm(in.) Φ31.75(1-1/4)	Φ31.75(1-1/4)	Φ31.75(1-1/4)	Φ31.75(1-1/4)	Φ31.75(1-1/4)
	Liquid Line	mm(in.) Φ19.05(3/4)	Φ19.05(3/4)	Φ19.05(3/4)	Φ19.05(3/4)	Φ19.05(3/4)
Heat Pump Operation System	Gas Line	mm(in.) Φ38.1(1-1/2)	Φ38.1(1-1/2)	Φ38.1(1-1/2)	Φ38.1(1-1/2)	Φ38.1(1-1/2)
	Liquid Line	mm(in.) Φ19.05(3/4)	Φ19.05(3/4)	Φ19.05(3/4)	Φ19.05(3/4)	Φ19.05(3/4)
Connectable Indoor Units	Quantity	pcs 64	64	64	64	64
	Total Capacity	– 200%*1	200%*1	200%*1	200%*1	200%*1
Piping Design	Height Difference Between ODU and IDU	m(above) 50(90°)	50(90°)	50(90°)	50(90°)	50(90°)
		m(below) 40(90°)	40(90°)	40(90°)	40(90°)	40(90°)
	Height Difference Between IDUs	m 15(30°)	15(30°)	15(30°)	15(30°)	15(30°)
	Max. Piping Length	m 165	165	165	165	165
Operation Range	Cooling	DB -10°C-52°C	-10°C-52°C	-10°C-52°C	-10°C-52°C	-10°C-52°C
	Heating	WB -25°C-16.5°C	-25°C-16.5°C	-25°C-16.5°C	-25°C-16.5°C	-25°C-16.5°C

Hi-FLEXi S Heat Recovery



HP		50HP	52HP	54HP	56HP
Model	Model	AVWT-482FKFSA	AVWT-504FKFSA	AVWT-522FKFSA	AVWT-544FKFSA
	Modules	AVWT-232FKFSA AVWT-250FKFSA	AVWT-232FKFSA AVWT-272FKFSA	AVWT-250FKFSA AVWT-272FKFSA	AVWT-272FKFSA AVWT-272FKFSA
Power Supply		AC 3Φ, 380-415V/50/60Hz			
Cooling	Capacity	kW 140.5	148.0	152.5	160.0
		kBtu/h 479.4	505.0	520.3	545.9
	Power Input	kW 42.51	44.85	46.15	48.48
	EER	kW/kW 3.31	3.30	3.30	3.30
Heating	Capacity(Max/Nom)	kW 155.0 / 140.5	165.0 / 148.0	170.0 / 152.5	180.0 / 160.0
		kBtu/h 528.9 / 479.4	563.0 / 505.0	580.0 / 520.3	614.2 / 545.9
	Power Input(Max/Nom)	kW 43.77 / 37.60	47.44 / 40.29	48.33 / 41.13	52.02 / 43.84
	COP(Max)	kW/kW 3.54	3.48	3.52	3.46
Ventilation	Air Flow Rate	m³/min 646	646	700	700
	Fan Quantity	4	4	4	4
	Static Pressure	Pa 110	110	110	110
Sound	Sound Pressure Level	dB(A) 70	70	70	70
Compressor	Type	Enhanced Vapor Injection Scroll Compressor			
	Compressor Quantity	4	4	4	4
Refrigerant	Type	R410A			
	Pre-charged Quantity	kg 10.60+11.50	10.60+11.50	11.50+11.50	11.50+11.50
Weight	Net Weight	kg 378+400	378+401	400+401	401+401
	Gross Weight	kg 402+426	402+427	426+427	427+427
Dimensions	External(HxWxD)	mm (1350+1600) x750	(1350+1600) x750	(1600+1600) x750	(1600+1600) x750
		mm 1930x	1930x	1930x	1930x
	Packing(HxWxD)	mm (1420+1665) x790	(1420+1665) x790	(1665+1665) x790	(1665+1665) x790
		mm 1930x	1930x	1930x	1930x
Cabinet Color		Ivory White	Ivory White	Ivory White	Ivory White
Heat Recovery Operation System	Low Pressure Gas Line	mm(in.) Φ38.1(1-1/2)	Φ38.1(1-1/2)	Φ38.1(1-1/2)	Φ41.3(1-5/8)
	High/Low Pressure Gas Line	mm(in.) Φ31.75(1-1/4)	Φ31.75(1-1/4)	Φ31.75(1-1/4)	Φ38.1(1-1/2)
	Liquid Line	mm(in.) Φ19.05(3/4)	Φ19.05(3/4)	Φ19.05(3/4)	Φ22.2(7/8)
Heat Pump Operation System	Gas Line	mm(in.) Φ38.1(1-1/2)	Φ38.1(1-1/2)	Φ38.1(1-1/2)	Φ41.3(1-5/8)
	Liquid Line	mm(in.) Φ19.05(3/4)	Φ19.05(3/4)	Φ19.05(3/4)	Φ22.2(7/8)
Connectable Indoor Units	Quantity	pcs 64	64	64	64
	Total Capacity	– 200%*1	200%*1	200%*1	200%*1
Piping Design	Height Difference Between ODU and IDU	m(above) 50(90°)	50(90°)	50(90°)	50(90°)
		m(below) 40(90°)	40(90°)	40(90°)	40(90°)
	Height Difference Between IDUs	m 15(30°)	15(30°)	15(30°)	15(30°)
	Max. Piping Length	m 165	165	165	165
Operation Range	Cooling	DB -10°C-52°C	-10°C-52°C	-10°C-52°C	-10°C-52°C
	Heating	WB -25°C-16.5°C	-25°C-16.5°C	-25°C-16.5°C	-25°C-16.5°C

RELIABILITY

EFFICIENCY

COMFORT

FLEXIBILITY

OUTDOOR UNIT

INDOOR UNIT

CONTROL SYSTEM

ACCESSORY

Hi-FLEXi S Heat Recovery



HP		58HP	60HP	62HP	64HP	
Model	Model	AVWT-552FKFSA	AVWT-570FKFSA	AVWT-592FKFSA	AVWT-612FKFSA	
	Modules	AVWT-170FKFSA	AVWT-190FKFSA	AVWT-170FKFSA	AVWT-190FKFSA	
		AVWT-170FKFSA	AVWT-190FKFSA	AVWT-190FKFSA	AVWT-232FKFSA	
Power Supply		AC 3Φ, 380-415V/50/60Hz				
Cooling	Capacity	kW	161.5	168.0	174.0	180.0
		kBtu/h	551.0	573.2	593.7	614.2
	Power Input	kW	46.11	46.80	50.18	51.72
	EER	kW/kW	3.50	3.59	3.47	3.48
Heating	Capacity(Max/Nom)	kW	181.0 / 161.5	189.0 / 168.0	194.0 / 174.0	201.0 / 180.0
		kBtu/h	617.6 / 551.0	644.9 / 573.2	661.9 / 593.7	685.8 / 614.2
	Power Input(Max/Nom)	kW	48.27 / 39.89	49.61 / 40.68	52.64 / 43.83	54.43 / 45.37
	COP(Max)	kW/kW	3.75	3.81	3.69	3.69
Ventilation	Air Flow Rate	m ³ /min	696	801	763	830
	Fan Quantity		6	6	6	6
	Static Pressure	Pa	110	110	110	110
Sound	Sound Pressure Level	dB(A)	70	70	70	70
Compressor	Type	Enhanced Vapor Injection Scroll Compressor				
	Compressor Quantity	pcs	6	6	6	6
Refrigerant	Type	R410A				
	Pre-charged Quantity	kg	9.20+9.20+10.60	9.80+9.80+9.80	9.20+9.80+10.60	9.80+9.80+10.60
Weight	Net Weight	kg	349+349+377	369+369+369	349+369+378	369+369+378
	Gross Weight	kg	371+371+401	393+393+393	371+393+402	393+393+402
Dimensions	External(HxWxD)	mm	1730x (1210+1210+1350) x750	1730x (1350+1350+1350) x750	1730x (1210+1350+1350) x750	1730x (1350+1350+1350) x750
		mm	1930x (1275+1275+1420) x790	1930x (1420+1420+1420) x790	1930x (1275+1420+1420) x790	1930x (1420+1420+1420) x790
	Packing(HxWxD)	mm	1930x (1275+1275+1420) x790	1930x (1420+1420+1420) x790	1930x (1275+1420+1420) x790	1930x (1420+1420+1420) x790
		mm	1930x (1275+1275+1420) x790	1930x (1420+1420+1420) x790	1930x (1275+1420+1420) x790	1930x (1420+1420+1420) x790
Cabinet Color		Ivory White	Ivory White	Ivory White	Ivory White	
Heat Recovery Operation System	Low Pressure Gas Line	mm(in.)	φ44.5(1-3/4)	φ44.5(1-3/4)	φ44.5(1-3/4)	φ44.5(1-3/4)
	High/Low Pressure Gas Line	mm(in.)	φ41.3(1-5/8)	φ41.3(1-5/8)	φ41.3(1-5/8)	φ41.3(1-5/8)
	Liquid Line	mm(in.)	φ22.2(7/8)	φ22.2(7/8)	φ22.2(7/8)	φ22.2(7/8)
Heat Pump Operation System	Gas Line	mm(in.)	φ44.5(1-3/4)	φ44.5(1-3/4)	φ44.5(1-3/4)	φ44.5(1-3/4)
	Liquid Line	mm(in.)	φ22.2(7/8)	φ22.2(7/8)	φ22.2(7/8)	φ22.2(7/8)
Connectable Indoor Units	Quantity	pcs	64	64	64	64
	Total Capacity	-	200%*1	200%*1	200%*1	200%*1
Piping Design	Height Difference Between ODU and IDU	m(above)	50(90°)	50(90°)	50(90°)	50(90°)
		m(below)	40(90°)	40(90°)	40(90°)	40(90°)
	Height Difference Between IDUs	m	15(30°)	15(30°)	15(30°)	15(30°)
	Max. Piping Length	m	165	165	165	165
Operation Range	Cooling	DB	-10°C-52°C	-10°C-52°C	-10°C-52°C	-10°C-52°C
	Heating	WB	-25°C-16.5°C	-25°C-16.5°C	-25°C-16.5°C	-25°C-16.5°C

Hi-FLEXi S Heat Recovery



HP		66HP	68HP	70HP	72HP	
Model	Model	AVWT-634FKFSA	AVWT-654FKFSA	AVWT-676FKFSA	AVWT-696FKFSA	
	Modules	AVWT-190FKFSA	AVWT-190FKFSA	AVWT-212FKFSA	AVWT-232FKFSA	
		AVWT-212FKFSA	AVWT-232FKFSA	AVWT-232FKFSA	AVWT-232FKFSA	
Power Supply		AC 3Φ, 380-415V/50/60Hz				
Cooling	Capacity	kW	185.5	192.0	197.5	204.0
		kBtu/h	632.9	655.1	673.9	696.0
	Power Input	kW	54.18	56.73	59.23	61.82
	EER	kW/kW	3.42	3.38	3.33	3.30
Heating	Capacity(Max/Nom)	kW	207.0 / 185.5	213.0 / 192.0	219.0 / 197.5	225.0 / 204.0
		kBtu/h	706.3 / 632.9	726.8 / 655.1	747.2 / 673.9	767.7 / 696.0
	Power Input(Max/Nom)	kW	56.72 / 47.74	59.33 / 50.20	61.63 / 52.62	64.29 / 55.14
	COP(Max)	kW/kW	3.65	3.59	3.55	3.50
Ventilation	Air Flow Rate	m ³ /min	859	859	888	888
	Fan Quantity		6	6	6	6
	Static Pressure	Pa	110	110	110	110
Sound	Sound Pressure Level	dB(A)	70	70	70	71
Compressor	Type	Enhanced Vapor Injection Scroll Compressor				
	Compressor Quantity	pcs	6	6	6	6
Refrigerant	Type	R410A				
	Pre-charged Quantity	kg	9.80+10.60+10.60	9.80+10.60+10.60	10.60+10.60+10.60	10.60+10.60+10.60
Weight	Net Weight	kg	369+377+378	369+378+378	377+378+378	378+378+378
	Gross Weight	kg	393+401+402	393+402+402	401+402+402	402+402+402
Dimensions	External(HxWxD)	mm	1730x (1350+1350+1350) x750	1730x (1350+1350+1350) x750	1730x (1350+1350+1350) x750	1730x (1350+1350+1350) x750
		mm	1930x (1420+1420+1420) x790	1930x (1420+1420+1420) x790	1930x (1420+1420+1420) x790	1930x (1420+1420+1420) x790
	Packing(HxWxD)	mm	1930x (1420+1420+1420) x790	1930x (1420+1420+1420) x790	1930x (1420+1420+1420) x790	1930x (1420+1420+1420) x790
		mm	1930x (1420+1420+1420) x790	1930x (1420+1420+1420) x790	1930x (1420+1420+1420) x790	1930x (1420+1420+1420) x790
Cabinet Color		Ivory White	Ivory White	Ivory White	Ivory White	
Heat Recovery Operation System	Low Pressure Gas Line	mm(in.)	φ44.5(1-3/4)	φ50.8(2)	φ50.8(2)	φ50.8(2)
	High/Low Pressure Gas Line	mm(in.)	φ41.3(1-5/8)	φ44.5(1-3/4)	φ44.5(1-3/4)	φ44.5(1-3/4)
	Liquid Line	mm(in.)	φ22.2(7/8)	φ25.4(1)	φ25.4(1)	φ25.4(1)
Heat Pump Operation System	Gas Line	mm(in.)	φ44.5(1-3/4)	φ50.8(2)	φ50.8(2)	φ50.8(2)
	Liquid Line	mm(in.)	φ22.2(7/8)	φ25.4(1)	φ25.4(1)	φ25.4(1)
Connectable Indoor Units	Quantity	pcs	64	64	64	64
	Total Capacity	-	200%*1	200%*1	200%*1	200%*1
Piping Design	Height Difference Between ODU and IDU	m(above)	50(90°)	50(90°)	50(90°)	50(90°)
		m(below)	40(90°)	40(90°)	40(90°)	40(90°)
	Height Difference Between IDUs	m	15(30°)	15(30°)	15(30°)	15(30°)
	Max. Piping Length	m	165	165	165	165
Operation Range	Cooling	DB	-10°C-52°C	-10°C-52°C	-10°C-52°C	-10°C-52°C
	Heating	WB	-25°C-16.5°C	-25°C-16.5°C	-25°C-16.5°C	-25°C-16.5°C

Hi-FLEXi S Heat Recovery



HP		74HP	76HP	78HP	80HP
Model	Model	AVWT-714FKFSA	AVWT-732FKFSA	AVWT-754FKFSA	AVWT-776FKFSA
	Modules	AVWT-232FKFSA	AVWT-232FKFSA	AVWT-232FKFSA	AVWT-232FKFSA
		AVWT-232FKFSA AVWT-250FKFSA	AVWT-250FKFSA AVWT-250FKFSA	AVWT-250FKFSA AVWT-272FKFSA	AVWT-272FKFSA
Power Supply		AC 3 ϕ , 380-415V/50/60Hz			
Cooling	Capacity	kW 208.5	213.0	220.5	228.0
		kBtu/h 711.4	726.8	752.3	777.9
	Power Input	kW 63.11	64.41	66.75	69.09
	EER	kW/kW 3.30	3.31	3.30	3.30
Heating	Capacity(Max/Nom)	kW 230.0 / 208.5	235.0 / 213.0	245.0 / 220.5	255.0 / 228.0
		kBtu/h 784.8 / 711.4	801.8 / 726.8	835.9 / 752.3	870.1 / 777.9
	Power Input(Max/Nom)	kW 65.19 / 55.98	66.11 / 56.83	69.76 / 59.51	73.45 / 62.21
	COP(Max)	kW/kW 3.53	3.55	3.51	3.47
Ventilation	Air Flow Rate	m ³ /min 942	996	996	996
	Fan Quantity	6	6	6	6
	Static Pressure	Pa 110	110	110	110
Sound	Sound Pressure Level	dB(A) 71	71	71	71
Compressor	Type	Enhanced Vapor Injection Scroll Compressor			
	Compressor Quantity	6	6	6	6
Refrigerant	Type	R410A			
	Pre-charged Quantity	kg 10.60+10.60+11.50	10.60+11.50+11.50	10.60+11.50+11.50	10.60+11.50+11.50
Weight	Net Weight	kg 378+378+400	378+400+400	378+401+401	378+401+401
	Gross Weight	kg 402+402+426	402+426+426	402+426+427	402+427+427
Dimensions	External(HxWxD)	mm 1730x (1350+1350+1600) x750	1730x (1350+1600+1600) x750	1730x (1350+1600+1600) x750	1730x (1350+1600+1600) x750
		mm 1930x (1420+1420+1665) x790	1930x (1420+1665+1665) x790	1930x (1420+1665+1665) x790	1930x (1420+1665+1665) x790
	Packing(HxWxD)	mm 1730x (1350+1350+1600) x750	1730x (1350+1600+1600) x750	1730x (1350+1600+1600) x750	1730x (1350+1600+1600) x750
		mm 1930x (1420+1420+1665) x790	1930x (1420+1665+1665) x790	1930x (1420+1665+1665) x790	1930x (1420+1665+1665) x790
Cabinet Color		Ivory White	Ivory White	Ivory White	Ivory White
Heat Recovery Operation System	Low Pressure Gas Line	mm(in.) ϕ 50.8(2)	ϕ 50.8(2)	ϕ 50.8(2)	ϕ 50.8(2)
	High/Low Pressure Gas Line	mm(in.) ϕ 44.5(1-3/4)	ϕ 44.5(1-3/4)	ϕ 44.5(1-3/4)	ϕ 44.5(1-3/4)
	Liquid Line	mm(in.) ϕ 25.4(1)	ϕ 25.4(1)	ϕ 25.4(1)	ϕ 25.4(1)
Heat Pump Operation System	Gas Line	mm(in.) ϕ 50.8(2)	ϕ 50.8(2)	ϕ 50.8(2)	ϕ 50.8(2)
	Liquid Line	mm(in.) ϕ 25.4(1)	ϕ 25.4(1)	ϕ 25.4(1)	ϕ 25.4(1)
Connectable Indoor Units	Quantity	64	64	64	64
	Total Capacity	200%*1	200%*1	200%*1	200%*1
Piping Design	Height Difference Between ODU and IDU	m(above) 50(90°)	50(90°)	50(90°)	50(90°)
		m(below) 40(90°)	40(90°)	40(90°)	40(90°)
	Height Difference Between IDUs	m 15(30°)	15(30°)	15(30°)	15(30°)
		m 165	165	165	165
Operation Range	Cooling	DB -10°C~52°C	-10°C~52°C	-10°C~52°C	-10°C~52°C
	Heating	WB -25°C~16.5°C	-25°C~16.5°C	-25°C~16.5°C	-25°C~16.5°C

Hi-FLEXi S Heat Recovery



HP		82HP	84HP	86HP	88HP
Model	Model	AVWT-794FKFSA	AVWT-816FKFSA	AVWT-824FKFSA	AVWT-844FKFSA
	Modules	AVWT-250FKFSA	AVWT-272FKFSA	AVWT-190FKFSA	AVWT-190FKFSA
		AVWT-272FKFSA AVWT-272FKFSA	AVWT-272FKFSA AVWT-272FKFSA	AVWT-212FKFSA AVWT-232FKFSA	AVWT-232FKFSA AVWT-232FKFSA
Power Supply		AC 3 ϕ , 380-415V/50/60Hz			
Cooling	Capacity	kW 232.5	240.0	241.5	248.0
		kBtu/h 793.3	818.9	824.0	846.2
	Power Input	kW 70.39	72.73	69.76	72.29
	EER	kW/kW 3.30	3.30	3.46	3.43
Heating	Capacity(Max/Nom)	kW 260.0 / 232.5	270.0 / 240.0	270.0 / 241.5	276.0 / 248.0
		kBtu/h 887.1 / 793.3	921.2 / 818.9	921.2 / 824.0	941.7 / 846.2
	Power Input(Max/Nom)	kW 74.33 / 63.05	78.03 / 65.75	73.24 / 61.26	75.83 / 63.69
	COP(Max)	kW/kW 3.50	3.46	3.69	3.64
Ventilation	Air Flow Rate	m ³ /min 1050	1050	1126	1126
	Fan Quantity	6	6	8	8
	Static Pressure	Pa 110	110	110	110
Sound	Sound Pressure Level	dB(A) 72	72	72	72
Compressor	Type	Enhanced Vapor Injection Scroll Compressor			
	Compressor Quantity	6	6	8	8
Refrigerant	Type	R410A			
	Pre-charged Quantity	kg 11.50+11.50+11.50	11.50+11.50+11.50	9.80+9.80+10.60+10.60	9.80+9.80+10.60+10.60
Weight	Net Weight	kg 400+401+401	401+401+401	369+369+377+378	369+369+378+378
	Gross Weight	kg 426+427+427	427+427+427	393+393+401+402	393+393+402+402
Dimensions	External(HxWxD)	mm 1730x (1600+1600+1600) x750	1730x (1600+1600+1600) x750	1730x (1350+1350+1350+1350) x750	1730x (1350+1350+1350+1350) x750
		mm 1930x (1665+1665+1665) x790	1930x (1665+1665+1665) x790	1930x (1420+1420+1420+1420) x790	1930x (1420+1420+1420+1420) x790
	Packing(HxWxD)	mm 1730x (1600+1600+1600) x750	1730x (1600+1600+1600) x750	1730x (1350+1350+1350+1350) x750	1730x (1350+1350+1350+1350) x750
		mm 1930x (1665+1665+1665) x790	1930x (1665+1665+1665) x790	1930x (1420+1420+1420+1420) x790	1930x (1420+1420+1420+1420) x790
Cabinet Color		Ivory White	Ivory White	Ivory White	Ivory White
Heat Recovery Operation System	Low Pressure Gas Line	mm(in.) ϕ 50.8(2)	ϕ 50.8(2)	ϕ 50.8(2)	ϕ 50.8(2)
	High/Low Pressure Gas Line	mm(in.) ϕ 44.5(1-3/4)	ϕ 44.5(1-3/4)	ϕ 44.5(1-3/4)	ϕ 44.5(1-3/4)
	Liquid Line	mm(in.) ϕ 25.4(1)	ϕ 25.4(1)	ϕ 25.4(1)	ϕ 25.4(1)
Heat Pump Operation System	Gas Line	mm(in.) ϕ 50.8(2)	ϕ 50.8(2)	ϕ 50.8(2)	ϕ 50.8(2)
	Liquid Line	mm(in.) ϕ 25.4(1)	ϕ 25.4(1)	ϕ 25.4(1)	ϕ 25.4(1)
Connectable Indoor Units	Quantity	64	64	64	64
	Total Capacity	200%*1	200%*1	200%*1	200%*1
Piping Design	Height Difference Between ODU and IDU	m(above) 50(90°)	50(90°)	50(90°)	50(90°)
		m(below) 40(90°)	40(90°)	40(90°)	40(90°)
	Height Difference Between IDUs	m 15(30°)	15(30°)	15(30°)	15(30°)
		m 165	165	165	165
Operation Range	Cooling	DB -10°C~52°C	-10°C~52°C	-10°C~52°C	-10°C~52°C
	Heating	WB -25°C~16.5°C	-25°C~16.5°C	-25°C~16.5°C	-25°C~16.5°C

Hi-FLEXi S Heat Recovery



HP		90HP	92HP	94HP	96HP	
Model	Model	AVWT-866FKFSA	AVWT-886FKFSA	AVWT-908FKFSA	AVWT-928FKFSA	
	Modules	AVWT-190FKFSA	AVWT-190FKFSA	AVWT-212FKFSA	AVWT-232FKFSA	
		AVWT-212FKFSA	AVWT-232FKFSA	AVWT-232FKFSA	AVWT-232FKFSA	
		AVWT-232FKFSA	AVWT-232FKFSA	AVWT-232FKFSA	AVWT-232FKFSA	
Power Supply		AC 3 ϕ , 380-415V/50/60Hz				
Cooling	Capacity	kW	253.5	260.0	265.5	272.0
		kBtu/h	864.9	887.1	905.9	928.1
	Power Input	kW	74.77	77.33	79.83	82.42
	EER	kW/kW	3.39	3.36	3.33	3.30
Heating	Capacity(Max/Nom)	kW	282.0 / 253.5	288.0 / 260.0	294.0 / 265.5	300.0 / 272.0
		kBtu/h	962.2 / 864.9	982.7 / 887.1	1003.1 / 905.9	1023.6 / 928.1
	Power Input(Max/Nom)	kW	78.12 / 66.09	80.75 / 68.56	83.06 / 71.00	85.71 / 73.51
	COP(Max)	kW/kW	3.61	3.57	3.54	3.50
Ventilation	Air Flow Rate	m ³ /min	1155	1155	1184	1184
	Fan Quantity		8	8	8	8
	Static Pressure	Pa	110	110	110	110
Sound	Sound Pressure Level	dB(A)	72	72	72	72
Compressor	Type	Enhanced Vapor Injection Scroll Compressor				
	Compressor Quantity	pcs	8	8	8	8
Refrigerant	Type	R410A				
	Pre-charged Quantity	kg	9.80+10.60+10.60+10.60	9.80+10.60+10.60+10.60	10.60+10.60+10.60+10.60	10.60+10.60+10.60+10.60
Weight	Net Weight	kg	369+377+378+378	369+378+378+378	377+378+378+378	378+378+378+378
	Gross Weight	kg	393+401+402+402	393+402+402+402	401+402+402+402	402+402+402+402
Dimensions	External(HxWxD)	mm	1730x (1350+1350+1350+1350)	1730x (1350+1350+1350+1350)	1730x (1350+1350+1350+1350)	1730x (1350+1350+1350+1350)
			x750	x750	x750	x750
	Packing(HxWxD)	mm	1930x (1420+1420+1420+1420)	1930x (1420+1420+1420+1420)	1930x (1420+1420+1420+1420)	1930x (1420+1420+1420+1420)
			x790	x790	x790	x790
Cabinet Color		Ivory White	Ivory White	Ivory White	Ivory White	
Heat Recovery Operation System	Low Pressure Gas Line	mm(in.)	ϕ 50.8(2)	ϕ 50.8(2)	ϕ 50.8(2)	ϕ 50.8(2)
	High/Low Pressure Gas Line	mm(in.)	ϕ 44.5(1-3/4)	ϕ 44.5(1-3/4)	ϕ 44.5(1-3/4)	ϕ 44.5(1-3/4)
	Liquid Line	mm(in.)	ϕ 25.4(1)	ϕ 25.4(1)	ϕ 25.4(1)	ϕ 25.4(1)
Heat Pump Operation System	Gas Line	mm(in.)	ϕ 50.8(2)	ϕ 50.8(2)	ϕ 50.8(2)	ϕ 50.8(2)
	Liquid Line	mm(in.)	ϕ 25.4(1)	ϕ 25.4(1)	ϕ 25.4(1)	ϕ 25.4(1)
Connectable Indoor Units	Quantity	pcs	64	64	64	64
	Total Capacity	-	200%*1	200%*1	200%*1	200%*1
Piping Design	Height Difference Between ODU and IDU	m(above)	50(90°)	50(90°)	50(90°)	50(90°)
		m(below)	40(90°)	40(90°)	40(90°)	40(90°)
	Height Difference Between IDUs	m	15(30°)	15(30°)	15(30°)	15(30°)
	Max. Piping Length	m	165	165	165	165
Operation Range	Cooling	DB	-10°C-52°C	-10°C-52°C	-10°C-52°C	-10°C-52°C
	Heating	WB	-25°C-16.5°C	-25°C-16.5°C	-25°C-16.5°C	-25°C-16.5°C

Hi-FLEXi S Heat Recovery



HP		98HP	100HP	102HP	104HP	
Model	Model	AVWT-946FKFSA	AVWT-968FKFSA	AVWT-988FKFSA	AVWT-1008FKFSA	
	Modules	AVWT-232FKFSA	AVWT-232FKFSA	AVWT-212FKFSA	AVWT-232FKFSA	
		AVWT-232FKFSA	AVWT-232FKFSA	AVWT-232FKFSA	AVWT-232FKFSA	
		AVWT-232FKFSA	AVWT-232FKFSA	AVWT-272FKFSA	AVWT-272FKFSA	
Power Supply		AC 3 ϕ , 380-415V/50/60Hz				
Cooling	Capacity	kW	276.5	284.0	289.5	296.0
		kBtu/h	943.4	969.0	987.8	1010.0
	Power Input	kW	83.72	86.06	87.10	89.70
	EER	kW/kW	3.30	3.30	3.32	3.30
Heating	Capacity(Max/Nom)	kW	305.0 / 276.5	315.0 / 284.0	324.0 / 289.5	330.0 / 296.0
		kBtu/h	1040.7 / 943.4	1074.8 / 969.0	1105.5 / 987.8	1126.0 / 1010.0
	Power Input(Max/Nom)	kW	86.62 / 74.36	90.29 / 77.05	92.19 / 78.05	94.87 / 80.59
	COP(Max)	kW/kW	3.52	3.49	3.51	3.48
Ventilation	Air Flow Rate	m ³ /min	1238	1238	1292	1292
	Fan Quantity		8	8	8	8
	Static Pressure	Pa	110	110	110	110
Sound	Sound Pressure Level	dB(A)	72	72	72	73
Compressor	Type	Enhanced Vapor Injection Scroll Compressor				
	Compressor Quantity	pcs	8	8	8	8
Refrigerant	Type	R410A				
	Pre-charged Quantity	kg	10.60+10.60+10.60+11.50	10.60+10.60+10.60+11.50	10.60+10.60+11.50+11.50	10.60+10.60+11.50+11.50
Weight	Net Weight	kg	378+378+378+400	378+378+378+401	377+378+401+401	378+378+401+401
	Gross Weight	kg	402+402+402+426	402+402+402+427	401+402+427+427	402+402+427+427
Dimensions	External(HxWxD)	mm	1730x (1350+1350+1350+1600)	1730x (1350+1350+1350+1600)	1730x (1350+1350+1600+1600)	1730x (1350+1350+1600+1600)
			x750	x750	x750	x750
	Packing(HxWxD)	mm	1930x (1420+1420+1420+1665)	1930x (1420+1420+1420+1665)	1930x (1420+1420+1665+1665)	1930x (1420+1420+1665+1665)
			x790	x790	x790	x790
Cabinet Color		Ivory White	Ivory White	Ivory White	Ivory White	
Heat Recovery Operation System	Low Pressure Gas Line	mm(in.)	ϕ 50.8(2)	ϕ 50.8(2)	ϕ 50.8(2)	ϕ 50.8(2)
	High/Low Pressure Gas Line	mm(in.)	ϕ 44.5(1-3/4)	ϕ 44.5(1-3/4)	ϕ 44.5(1-3/4)	ϕ 44.5(1-3/4)
	Liquid Line	mm(in.)	ϕ 25.4(1)	ϕ 25.4(1)	ϕ 25.4(1)	ϕ 25.4(1)
Heat Pump Operation System	Gas Line	mm(in.)	ϕ 50.8(2)	ϕ 50.8(2)	ϕ 50.8(2)	ϕ 50.8(2)
	Liquid Line	mm(in.)	ϕ 25.4(1)	ϕ 25.4(1)	ϕ 25.4(1)	ϕ 25.4(1)
Connectable Indoor Units	Quantity	pcs	64	64	64	64
	Total Capacity	-	200%*1	200%*1	200%*1	200%*1
Piping Design	Height Difference Between ODU and IDU	m(above)	50(90°)	50(90°)	50(90°)	50(90°)
		m(below)	40(90°)	40(90°)	40(90°)	40(90°)
	Height Difference Between IDUs	m	15(30°)	15(30°)	15(30°)	15(30°)
	Max. Piping Length	m	165	165	165	165
Operation Range	Cooling	DB	-10°C-52°C	-10°C-52°C	-10°C-52°C	-10°C-52°C
	Heating	WB	-25°C-16.5°C	-25°C-16.5°C	-25°C-16.5°C	-25°C-16.5°C

Hi-FLEXi S Heat Recovery



HP		106HP	108HP	110HP	112HP	
Model	Model	AVWT-1026FKFSA	AVWT-1048FKFSA	AVWT-1066FKFSA	AVWT-1088FKFSA	
	Modules	AVWT-232FKFSA	AVWT-232FKFSA	AVWT-250FKFSA	AVWT-272FKFSA	
		AVWT-250FKFSA	AVWT-272FKFSA	AVWT-272FKFSA	AVWT-272FKFSA	
		AVWT-272FKFSA	AVWT-272FKFSA	AVWT-272FKFSA	AVWT-272FKFSA	
		AVWT-272FKFSA	AVWT-272FKFSA	AVWT-272FKFSA	AVWT-272FKFSA	
Power Supply	AC 3Φ, 380-415V/50/60Hz					
Cooling	Capacity	kW	300.5	308.0	312.5	320.0
		kBtu/h	1025.3	1050.9	1066.3	1091.8
	Power Input	kW	90.99	93.33	94.63	96.97
	EER	kW/kW	3.30	3.30	3.30	3.30
Heating	Capacity(Max/Nom)	kW	335.0 / 300.5	345.0 / 308.0	350.0 / 312.5	360.0 / 320.0
		kBtu/h	1143.0 / 1025.3	1177.1 / 1050.9	1194.2 / 1066.3	1228.3 / 1091.8
	Power Input(Max/Nom)	kW	95.76 / 81.42	99.46 / 84.13	100.34 / 84.96	104.05 / 87.67
	COP(Max)	kW/kW	3.50	3.47	3.49	3.46
Ventilation	Air Flow Rate	m ³ /min	1346	1346	1400	1400
	Fan Quantity		8	8	8	8
	Static Pressure	Pa	110	110	110	110
Sound	Sound Pressure Level	dB(A)	73	73	73	73
Compressor	Type	Enhanced Vapor Injection Scroll Compressor				
	Compressor Quantity	pcs	8	8	8	8
Refrigerant	Type	R410A				
	Pre-charged Quantity	kg	10.60+11.50+11.50+11.50	10.60+11.50+11.50+11.50	11.50+11.50+11.50+11.50	11.50+11.50+11.50+11.50
Weight	Net Weight	kg	378+400+401+401	378+401+401+401	400+401+401+401	401+401+401+401
	Gross Weight	kg	402+426+427+427	402+427+427+427	426+427+427+427	427+427+427+427
Dimensions	External(HxWxD)	mm	1730x (1350+1600+1600+1600)	1730x (1350+1600+1600+1600)	1730x (1600+1600+1600+1600)	1730x (1600+1600+1600+1600)
			x750	x750	x750	x750
	Packing(HxWxD)	mm	1930x (1420+1665+1665+1665)	1930x (1420+1665+1665+1665)	1930x (1665+1665+1665+1665)	1930x (1665+1665+1665+1665)
			x790	x790	x790	x790
Cabinet Color		Ivory White	Ivory White	Ivory White	Ivory White	
Heat Recovery Operation System	Low Pressure Gas Line	mm(in.)	φ50.8(2)	φ50.8(2)	φ50.8(2)	φ50.8(2)
	High/Low Pressure Gas Line	mm(in.)	φ44.5(1-3/4)	φ44.5(1-3/4)	φ44.5(1-3/4)	φ44.5(1-3/4)
	Liquid Line	mm(in.)	φ25.4(1)	φ25.4(1)	φ25.4(1)	φ25.4(1)
Heat Pump Operation System	Gas Line	mm(in.)	φ50.8(2)	φ50.8(2)	φ50.8(2)	φ50.8(2)
	Liquid Line	mm(in.)	φ25.4(1)	φ25.4(1)	φ25.4(1)	φ25.4(1)
Connectable Indoor Units	Quantity	pcs	64	64	64	64
	Total Capacity	-	200%*1	200%*1	200%*1	200%*1
Piping Design	Height Difference Between ODU and IDU	m(above)	50(90°)	50(90°)	50(90°)	50(90°)
		m(below)	40(90°)	40(90°)	40(90°)	40(90°)
	Height Difference Between IDUs	m	15(30°)	15(30°)	15(30°)	15(30°)
	Max. Piping Length	m	165	165	165	165
Operation Range	Cooling	DB	-10°C-52°C	-10°C-52°C	-10°C-52°C	-10°C-52°C
	Heating	WB	-25°C-16.5°C	-25°C-16.5°C	-25°C-16.5°C	-25°C-16.5°C

NOTES:

- Rated cooling capacity and rated heating capacity are tested in the following conditions:
Cooling conditions: indoor air inlet temperature: 27°C DB 19°C WB, outdoor air inlet temperature: 35°C DB, pipe length: 7.5m, pipe height difference: 0m.
Heating conditions: indoor air inlet temperature: 20°C DB, outdoor air inlet temperature: 7°C DB 6°C WB, pipe length: 7.5m, pipe height difference: 0m.
- The above noise values are measured in the anechoic chamber without reflected echo, therefore the impact of the reflected echo must be included at the scene.
- The final appearance of outdoor units is subject to the actual products.

*1: If you have any questions, please contact with the technical engineer.

*2: For detailed information, please contact with Hisense's technical staff.

Switch Box

Introduction

Used for heat recovery systems to achieve simultaneous cooling and heating in a system, it is very important to realize installation flexibility and reduce costs.

Advantage

- Enrich the products (1,4,8,12,16).
- Maximize capacity to 16kW or more.
- Require no drain pipes or drainage connections.
- Combine between single branch and multi-branch flexibility.
- Enable fewer connections, hooks and service parts for easy installation.

Original Products

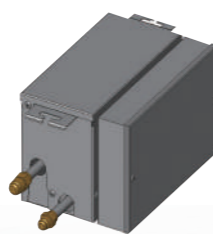

New Switch Box



Model	Single Branch		Multi Branch						
	HCHS-N06XA	HCHS-N10XA	HCHM-N04XA	HCHM-N08XA	HCHM-N12XA	HCHM-N16XA			
Appearance									
Electrical	AC 1Φ, 220-240V/50/60Hz								
Power Supply	-								
Power Input	W	5	5	11.2	22.4	33.6	44.8		
Maximum Total Capacity Index	kW	16	28	44.8	85	85	85		
Number of Branches	-	1	1	4	8	12	16		
Maximum Capacity Index per Branch	kW	-	-	16	16	16	16		
Maximum Connectable Indoor Units per Branch	pics	8	8	8	8	6	6		
Dimensions (H x W x D)	mm	191 x 301 x 214	191 x 301 x 214	260 x 303 x 352	260 x 543 x 352	260 x 783 x 352	260 x 1023 x 352		
Refrigerant	R410A								
Refrigerant	Outdoor Unit Side	Gas Line (High and Low Pressure Side)	mm (in.)	φ 15.88(5/8)	φ 15.88(5/8)	φ 22.20(7/8)	φ 22.20(7/8)	φ 25.40(1)	φ 28.58(1-1/8)
		Gas Line (Suction Gas)	mm (in.)	φ 19.05(3/4)	φ 19.05(3/4)	φ 25.40(1)	φ 28.58(1-1/8)	φ 28.58(1-1/8)	φ 31.75(1-1/4)
		Liquid Line	mm (in.)	Not Included	Not Included	φ 12.70(1/2)	φ 12.70(1/2)	φ 15.88(5/8)	φ 19.05(3/4)
Piping	Indoor Unit Side	Gas Line	mm (in.)	φ 15.88(5/8)	φ 19.05(3/4)	φ 15.88(5/8)	φ 15.88(5/8)	φ 15.88(5/8)	φ 15.88(5/8)
		Liquid Line	mm (in.)	Not Included	Not Included	φ 9.52(3/8)	φ 9.52(3/8)	φ 9.52(3/8)	φ 9.52(3/8)
Net Weight	kg	6.3	6.4	14.1	25.2	35.5	46.7		
Noise Level	Sound Pressure Level	dB (A)	33	33	31	31	34	34	
	Max Sound	dB (A)	46	46	43	46	48	49	

Hydro Box

Specification for Hydro Box

Model		AHM-080FJFAA	AHM-160FJFAA
Power Supply		AC 1Φ, 220~240V/50Hz AC 1Φ, 220V/60Hz	
Cooling Capacity (A 35/24°C/W 12~7°C)		7.5	12.5
Heating Capacity (A 7/6°C/W 30~35°C)	kW	8	16
Power Input	kW	0.08(3.08)	0.14(3.14)
Dimensions	H x W x D	mm	890 x 520 x 320
Packing Dimensions	H x W x D	mm	1120 x 595 x 462
Weight	Net	kg	55
	Gross	kg	72
Heat Exchanger		Plate Heat Exchanger	
Heat Exchanger Insulation Material		Elastomeric Foam	
Water Production	Heating	°C	20 to 55
	DHW(with electric heater)	°C	35 to 75
Sound Pressure	Cooling	°C	5 to 20
		dB(A)	33
Sound Power		dB(A)	46
Piping Connections	Gas	mm	φ 15.88
	Liquid	mm	φ 9.53
Water Pump	Type		DC Motor
	Speed		Inverter Control
	Pumping Head	m	12.5
Booster Heating	Pumping Head for Water Circuit		5
	Power Input	w	100
		kW	3
Water Filter	Diameter Perforations	mm	0.85
	Material		Hpb59-1
Water Circuit	Piping Connections Diameter	mm	G1-1/4"
	Shut off Valve		Yes
	Drain Valve		Yes
	Safety Valve	Bar	3
	Air Purge Valve		Yes
Nominal Water	m³/h	1.38	2.75
Expansion Vessel	Volume	L	8
	Max. Water Pressure	Bar	3

Operation Range

Indoor Unit Cooling

	Maximum	Minimum
Indoor	32°C DB / 23°C WB	21°C DB / 15°C WB
Outdoor	52°C DB*	-10°C DB

Indoor Unit Heating

	Maximum	Minimum
Indoor	27°C DB	15°C DB
Outdoor	16.5°C WB	-25°C WB**

Hydro Box Cooling

	Maximum	Minimum
Inlet Water	25°C	10°C
Outdoor	48°C DB	10°C DB

Hydro Box Heating (Floor Heating)

	Maximum	Minimum
Inlet Water	54°C	10°C
Outdoor	16.5°C WB	-25°C WB**

Hydro Box Heating (DHW)

	Maximum	Minimum
Inlet Water	54°C	10°C
Outdoor	43°C WB	-25°C WB**

DB: Dry Bulb
WB: Wet Bulb
(*) 48°C DB ~ 52°C DB, Operation Control Range
(**) -20°C WB ~ -25°C WB, Operation Control Range



Hi-FLEXi S Series



Piping Length

With extra long pipe, the height difference between the indoor unit and outdoor unit is up to 90 meters*, which makes installation more flexible.

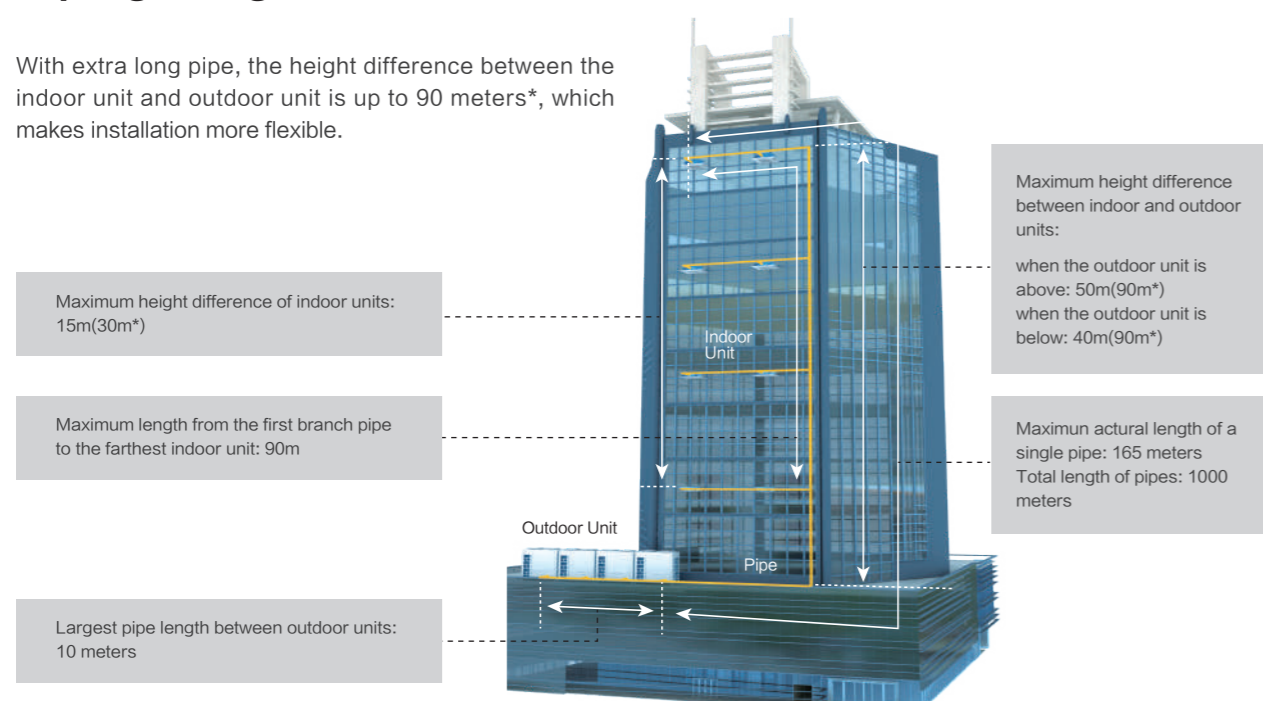

*Note: For detailed information, please contact Hisense's technical staff.

Hi-FLEXi S Series



HP		8HP	10HP	12HP	14HP	16HP	18HP	
Model		AVWT-76HKSS	AVWT-96HKSS	AVWT-114HKSS	AVWT-136HKSS	AVWT-154HKSS	AVWT-170HKSS	
Model	Modules	—	—	—	—	—	—	
Power Supply		AC 3φ, 380-415V/50/60Hz						
Cooling	Capacity	kW	22.4	28.0	33.5	40.0	50.0	
		kBtu/h	76.4	95.5	114.3	136.5	153.5	170.6
	Power Input	kW	5.21	7.00	8.65	10.53	12.50	15.63
	EER	kW/kW	4.30	4.00	3.87	3.80	3.60	3.20
Heating	Capacity	kW	25.0	31.5	37.5	45.0	50.0	56.0
		kBtu/h	85.3	107.5	128.0	153.5	170.6	191.1
	Power Input	kW	5.77	7.59	9.21	11.72	13.70	16.97
	COP	kW/kW	4.33	4.15	4.07	3.84	3.65	3.30
Ventilation	Air Flow Rate	m ³ /min	183	183	183	200	200	200
	Fan Quantity		1	1	1	2	2	2
	Static Pressure	Pa	110	110	110	110	110	110
Sound	Sound Pressure Level	dB(A)	59	60	62	62	62	62
	Type	—	Enhanced Vapor Injection Compressor					
Compressor	Compressor Quantity	pcs	1	1	1	1	1	2
	Type	—	R410A					
Refrigerant	Pre-charged Quantity	kg	7.4	8.6	9.5	12.0	12.0	13.2
	Net Weight	kg	224	244	245	297	298	347
Weight	Gross Weight	kg	243	263	265	321	322	371
	External(HxWxD)	mm	1730x950x750	1730x950x750	1730x950x750	1730x1210x750	1730x1210x750	1730x1210x750
Dimensions	Packing(HxWxD)	mm	1930x1015x790	1930x1015x790	1930x1015x790	1930x1275x790	1930x1275x790	1930x1275x790
	Cabinet Color		Ivory White	Ivory White	Ivory White	Ivory White	Ivory White	Ivory White
Ref. Piping	Gas	mm	φ19.05	φ22.20	φ25.40	φ25.40	φ28.60	φ28.60
		inch	3/4	7/8	1	1	1-1/8	1-1/8
	Liquid	mm	φ9.53	φ9.53	φ12.70	φ12.70	φ12.70	φ15.88
		inch	3/8	3/8	1/2	1/2	1/2	5/8
Connectable Indoor Units	Quantity	pcs	13	16	19	23	26	29
	Total Capacity	—	50%~150%	50%~150%	50%~150%	50%~150%	50%~150%	50%~150%
Piping Design	Height Difference Between ODU and IDU	m(above)	50 (90 ^m *)	50 (90 ^m *)	50 (90 ^m *)	50 (90 ^m *)	50 (90 ^m *)	50 (90 ^m *)
		m(below)	40 (90 ^m *)	40 (90 ^m *)	40 (90 ^m *)	40 (90 ^m *)	40 (90 ^m *)	40 (90 ^m *)
	Height Difference Between IDUs	m	15 (30 ^m *)	15 (30 ^m *)	15 (30 ^m *)	15 (30 ^m *)	15 (30 ^m *)	15 (30 ^m *)
	Max. Piping Length	m	165	165	165	165	165	165
Operation Range	Cooling	DB	-5°C-52°C	-5°C-52°C	-5°C-52°C	-5°C-52°C	-5°C-52°C	-5°C-52°C
	Heating	WB	-25°C-16.5°C	-25°C-16.5°C	-25°C-16.5°C	-25°C-16.5°C	-25°C-16.5°C	-25°C-16.5°C

Hi-FLEXi S Series



Hi-FLEXi S Series



HP		20HP	22HP	24HP	26HP	28HP	
Model	Model	AVWT-190HKSS	AVWT-212HKSS	AVWT-232HKSS	AVWT-250HKSS	AVWT-272HKSS	
Model	Modules	—	—	—	—	—	
	Power Supply	AC 3 ϕ , 380-415V/50/60Hz					
Cooling	Capacity	kW	56.0	61.5	68.0	72.5	80.0
		kBtu/h	191.1	209.8	232.1	246.5	272.0
	Power Input	kW	17.90	20.50	22.82	24.58	27.59
	EER	kW/kW	3.13	3.00	2.98	2.95	2.90
Heating	Capacity	kW	63.0	69.0	75.0	80.0	90.0
		kBtu/h	215.0	235.4	255.0	272.0	306.0
	Power Input	kW	19.87	22.48	24.59	26.67	30.41
	COP	kW/kW	3.17	3.07	3.05	3.00	2.96
Ventilation	Air Flow Rate	m ³ /min	267	296	296	350	350
	Fan Quantity		2	2	2	2	2
	Static Pressure	Pa	110	110	110	110	110
Sound	Sound Pressure Level	dB(A)	63	64	66	67	67
Compressor	Type	Enhanced Vapor Injection Scroll Compressor					
	Compressor Quantity	pcs	2	2	2	2	2
Refrigerant	Type	R410A					
	Pre-charged Quantity	kg	14.3	15.5	15.5	17.3	17.3
Weight	Net Weight	kg	361	369	370	414	415
	Gross Weight	kg	395	396	397	446	447
Dimensions	External(HxWxD)	mm	1730x1350x750	1730x1350x750	1730x1350x750	1730x1600x750	1730x1600x750
	Packing(HxWxD)	mm	1930x1420x790	1930x1420x790	1930x1420x790	1930x1665x790	1930x1665x790
Cabinet Color		Ivory White	Ivory White	Ivory White	Ivory White	Ivory White	
Ref. Piping	Gas	mm	ϕ 28.60	ϕ 28.60	ϕ 28.60	ϕ 31.75	ϕ 31.75
		inch	1-1/8	1-1/8	1-1/8	1-1/4	1-1/4
	Liquid	mm	ϕ 15.88	ϕ 15.88	ϕ 15.88	ϕ 19.05	ϕ 19.05
		inch	5/8	5/8	5/8	3/4	3/4
Connectable Indoor Units	Quantity	pcs	33	36	40	43	47
	Total Capacity	—	50%-150%	50%-150%	50%-150%	50%-150%	50%-150%
Piping Design	Height Difference Between ODU and IDU	m(above)	50 (90 ^{**})	50 (90 ^{**})	50 (90 ^{**})	50 (90 ^{**})	50 (90 ^{**})
		m(below)	40 (90 ^{**})	40 (90 ^{**})	40 (90 ^{**})	40 (90 ^{**})	40 (90 ^{**})
	Height Difference Between IDUs	m	15 (30 ^{**})	15 (30 ^{**})	15 (30 ^{**})	15 (30 ^{**})	15 (30 ^{**})
	Max. Piping Length	m	165	165	165	165	165
Operation Range	Cooling	DB	-5 $^{\circ}$ C-52 $^{\circ}$ C	-5 $^{\circ}$ C-52 $^{\circ}$ C	-5 $^{\circ}$ C-52 $^{\circ}$ C	-5 $^{\circ}$ C-52 $^{\circ}$ C	-5 $^{\circ}$ C-52 $^{\circ}$ C
	Heating	WB	-25 $^{\circ}$ C-16.5 $^{\circ}$ C	-25 $^{\circ}$ C-16.5 $^{\circ}$ C	-25 $^{\circ}$ C-16.5 $^{\circ}$ C	-25 $^{\circ}$ C-16.5 $^{\circ}$ C	-25 $^{\circ}$ C-16.5 $^{\circ}$ C

HP		30HP	32HP	34HP	36HP	38HP	
Model	Model	AVWT-290HKSS	AVWT-308HKSS	AVWT-324HKSS	AVWT-344HKSS	AVWT-360HKSS	
Model	Modules	AVWT-154HKSS AVWT-136HKSS	AVWT-154HKSS AVWT-154HKSS	AVWT-170HKSS AVWT-154HKSS	AVWT-190HKSS AVWT-154HKSS	AVWT-190HKSS AVWT-170HKSS	
	Power Supply	AC 3 ϕ , 380-415V/50/60Hz					
Cooling	Capacity	kW	85.0	90.0	95.0	101.0	106.0
		kBtu/h	290.0	307.0	324.1	344.6	361.7
	Power Input	kW	23.03	25.00	28.13	30.40	33.53
	EER	kW/kW	3.69	3.60	3.38	3.32	3.16
Heating	Capacity	kW	95.0	100.0	106.0	113.0	119.0
		kBtu/h	324.1	341.2	361.7	385.6	406.1
	Power Input	kW	25.42	27.40	30.67	33.57	36.84
	COP	kW/kW	3.74	3.65	3.46	3.37	3.23
Ventilation	Air Flow Rate	m ³ /min	400	400	400	467	467
	Fan Quantity		4	4	4	4	4
	Static Pressure	Pa	110	110	110	110	110
Sound	Sound Pressure Level	dB(A)	67	67	67	67	67
Compressor	Type	Enhanced Vapor Injection Scroll Compressor					
	Compressor Quantity	pcs	2	2	3	3	4
Refrigerant	Type	R410A					
	Pre-charged Quantity	kg	24.0	24.0	25.20	26.30	27.5
Weight	Net Weight	kg	595	596	645	659	708
	Gross Weight	kg	643	644	693	717	766
Dimensions	External(HxWxD)	mm	1730x (1210+1210) x750	1730x (1210+1210) x750	1730x (1210+1210) x750	1730x (1210+1350) x750	1730x (1210+1350) x750
	Packing(HxWxD)	mm	1930x (1275+1275) x790	1930x (1275+1275) x790	1930x (1275+1275) x790	1930x (1275+1420) x790	1930x (1275+1420) x790
Cabinet Color		Ivory White	Ivory White	Ivory White	Ivory White	Ivory White	
Ref. Piping	Gas	mm	ϕ 31.75	ϕ 31.75	ϕ 38.1	ϕ 38.1	ϕ 38.1
		inch	1-1/4	1-1/4	1-1/2	1-1/2	1-1/2
	Liquid	mm	ϕ 19.05	ϕ 19.05	ϕ 19.05	ϕ 19.05	ϕ 19.05
		inch	3/4	3/4	3/4	3/4	3/4
Connectable Indoor Units	Quantity	pcs	49	52	55	59	62
	Total Capacity	—	50%-150%	50%-150%	50%-150%	50%-150%	50%-150%
Piping Design	Height Difference Between ODU and IDU	m(above)	50 (90 ^{**})	50 (90 ^{**})	50 (90 ^{**})	50 (90 ^{**})	50 (90 ^{**})
		m(below)	40 (90 ^{**})	40 (90 ^{**})	40 (90 ^{**})	40 (90 ^{**})	40 (90 ^{**})
	Height Difference Between IDUs	m	15 (30 ^{**})	15 (30 ^{**})	15 (30 ^{**})	15 (30 ^{**})	15 (30 ^{**})
	Max. Piping Length	m	165	165	165	165	165
Operation Range	Cooling	DB	-5 $^{\circ}$ C-52 $^{\circ}$ C	-5 $^{\circ}$ C-52 $^{\circ}$ C	-5 $^{\circ}$ C-52 $^{\circ}$ C	-5 $^{\circ}$ C-52 $^{\circ}$ C	-5 $^{\circ}$ C-52 $^{\circ}$ C
	Heating	WB	-25 $^{\circ}$ C-16.5 $^{\circ}$ C	-25 $^{\circ}$ C-16.5 $^{\circ}$ C	-25 $^{\circ}$ C-16.5 $^{\circ}$ C	-25 $^{\circ}$ C-16.5 $^{\circ}$ C	-25 $^{\circ}$ C-16.5 $^{\circ}$ C

Hi-FLEXi S Series



HP		40HP	42HP	44HP	46HP	48HP	
Model	Model	AVWT-380HKSS	AVWT-402HKSS	AVWT-422HKSS	AVWT-444HKSS	AVWT-464HKSS	
	Modules	AVWT-190HKSS AVWT-190HKSS	AVWT-232HKSS AVWT-170HKSS	AVWT-232HKSS AVWT-190HKSS	AVWT-232HKSS AVWT-212HKSS	AVWT-232HKSS AVWT-232HKSS	
Power Supply		AC 3 ϕ , 380-415V/50/60Hz					
Cooling	Capacity	kW	112.0	118.0	124.0	129.5	136.0
		kBtu/h	382.1	402.7	432.2	441.9	464.2
	Power Input	kW	35.80	38.45	40.72	43.32	45.64
	EER	kW/kW	3.13	3.07	3.05	2.99	2.98
Heating	Capacity	kW	126.0	131.0	138.0	144.0	150.0
		kBtu/h	430.0	446.1	470.0	490.4	510.0
	Power Input	kW	39.74	41.56	44.46	47.07	49.18
	COP	kW/kW	3.17	3.15	3.10	3.06	3.05
Ventilation	Air Flow Rate	m ³ /min	534	496	563	592	592
	Fan Quantity		4	4	4	4	4
	Static Pressure	Pa	110	110	110	110	110
Sound	Sound Pressure Level	dB(A)	67	67	68	68	69
Compressor	Type	Enhanced Vapor Injection Scroll Compressor					
	Compressor Quantity	pcs	4	4	4	4	4
Refrigerant	Type	R410A					
	Pre-charged Quantity	kg	28.6	28.7	29.8	31.0	31.0
Weight	Net Weight	kg	722	717	731	739	740
	Gross Weight	kg	790	768	792	793	794
Dimensions	External(HxWxD)	mm	1730x (1350+1350) x750	1730x (1210+1350) x750	1730x (1350+1350) x750	1730x (1350+1350) x750	1730x (1350+1350) x750
		mm	1930x (1420+1420) x790	1930x (1275+1420) x790	1930x (1420+1420) x790	1930x (1420+1420) x790	1930x (1420+1420) x790
	Packing(HxWxD)	mm	1930x (1420+1420) x790	1930x (1275+1420) x790	1930x (1420+1420) x790	1930x (1420+1420) x790	1930x (1420+1420) x790
		mm	1930x (1420+1420) x790	1930x (1275+1420) x790	1930x (1420+1420) x790	1930x (1420+1420) x790	1930x (1420+1420) x790
Cabinet Color		Ivory White	Ivory White	Ivory White	Ivory White	Ivory White	
Ref. Piping	Gas	mm	ϕ 38.1	ϕ 38.1	ϕ 38.1	ϕ 41.3	ϕ 41.3
		inch	1-1/2	1-1/2	1-1/2	1-5/8	1-5/8
	Liquid	mm	ϕ 19.05	ϕ 19.05	ϕ 19.05	ϕ 22.2	ϕ 22.2
		inch	3/4	3/4	3/4	7/8	7/8
Connectable Indoor Units	Quantity	pcs	64	64	64	64	64
	Total Capacity	-	50%-150%	50%-150%	50%-150%	50%-150%	50%-150%
Piping Design	Height Difference Between ODU and IDU	m(above)	50 (90 ^{**})	50 (90 ^{**})	50 (90 ^{**})	50 (90 ^{**})	50 (90 ^{**})
		m(below)	40 (90 ^{**})	40 (90 ^{**})	40 (90 ^{**})	40 (90 ^{**})	40 (90 ^{**})
	Height Difference Between IDUs	m	15 (30 ^{**})	15 (30 ^{**})	15 (30 ^{**})	15 (30 ^{**})	15 (30 ^{**})
	Max. Piping Length	m	165	165	165	165	165
Operation Range	Cooling	DB	-5 $^{\circ}$ C-52 $^{\circ}$ C	-5 $^{\circ}$ C-52 $^{\circ}$ C	-5 $^{\circ}$ C-52 $^{\circ}$ C	-5 $^{\circ}$ C-52 $^{\circ}$ C	-5 $^{\circ}$ C-52 $^{\circ}$ C
	Heating	WB	-25 $^{\circ}$ C-16.5 $^{\circ}$ C	-25 $^{\circ}$ C-16.5 $^{\circ}$ C	-25 $^{\circ}$ C-16.5 $^{\circ}$ C	-25 $^{\circ}$ C-16.5 $^{\circ}$ C	-25 $^{\circ}$ C-16.5 $^{\circ}$ C

Hi-FLEXi S Series



HP		50HP	52HP	54HP	56HP	
Model	Model	AVWT-482HKSS	AVWT-504HKSS	AVWT-522HKSS	AVWT-544HKSS	
	Modules	AVWT-250HKSS AVWT-232HKSS	AVWT-272HKSS AVWT-232HKSS	AVWT-272HKSS AVWT-250HKSS	AVWT-272HKSS AVWT-272HKSS	
Power Supply		AC 3 ϕ , 380-415V/50/60Hz				
Cooling	Capacity	kW	140.5	148.0	152.5	160.0
		kBtu/h	478.6	504.1	518.5	544.0
	Power Input	kW	47.40	50.41	52.17	55.18
	EER	kW/kW	2.96	2.94	2.92	2.90
Heating	Capacity	kW	155.0	165.0	170.0	180.0
		kBtu/h	527.0	561.0	578.0	612.0
	Power Input	kW	51.26	55.00	57.08	60.82
	COP	kW/kW	3.02	3.00	2.98	2.96
Ventilation	Air Flow Rate	m ³ /min	646	646	700	700
	Fan Quantity		4	4	4	4
	Static Pressure	Pa	110	110	110	110
Sound	Sound Pressure Level	dB(A)	70	70	70	70
Compressor	Type	Enhanced Vapor Injection Scroll Compressor				
	Compressor Quantity	pcs	4	4	4	4
Refrigerant	Type	R410A				
	Pre-charged Quantity	kg	32.8	32.8	34.6	34.6
Weight	Net Weight	kg	784	785	829	830
	Gross Weight	kg	843	844	893	894
Dimensions	External(HxWxD)	mm	1730x (1350+1600) x750	1730x (1350+1600) x750	1730x (1600+1600) x750	1730x (1600+1600) x750
		mm	1930x (1420+1665) x790	1930x (1420+1665) x790	1930x (1665+1665) x790	1930x (1665+1665) x790
	Packing(HxWxD)	mm	1930x (1420+1665) x790	1930x (1420+1665) x790	1930x (1665+1665) x790	1930x (1665+1665) x790
		mm	1930x (1420+1665) x790	1930x (1420+1665) x790	1930x (1665+1665) x790	1930x (1665+1665) x790
Cabinet Color		Ivory White	Ivory White	Ivory White	Ivory White	
Ref. Piping	Gas	mm	ϕ 41.3	ϕ 41.3	ϕ 41.3	ϕ 41.3
		inch	1-5/8	1-5/8	1-5/8	1-5/8
	Liquid	mm	ϕ 22.2	ϕ 22.2	ϕ 22.2	ϕ 22.2
		inch	7/8	7/8	7/8	7/8
Connectable Indoor Units	Quantity	pcs	64	64	64	64
	Total Capacity	-	50%-150%	50%-150%	50%-150%	50%-150%
Piping Design	Height Difference Between ODU and IDU	m(above)	50 (90 ^{**})	50 (90 ^{**})	50 (90 ^{**})	50 (90 ^{**})
		m(below)	40 (90 ^{**})	40 (90 ^{**})	40 (90 ^{**})	40 (90 ^{**})
	Height Difference Between IDUs	m	15 (30 ^{**})	15 (30 ^{**})	15 (30 ^{**})	15 (30 ^{**})
	Max. Piping Length	m	165	165	165	165
Operation Range	Cooling	DB	-5 $^{\circ}$ C-52 $^{\circ}$ C	-5 $^{\circ}$ C-52 $^{\circ}$ C	-5 $^{\circ}$ C-52 $^{\circ}$ C	-5 $^{\circ}$ C-52 $^{\circ}$ C
	Heating	WB	-25 $^{\circ}$ C-16.5 $^{\circ}$ C	-25 $^{\circ}$ C-16.5 $^{\circ}$ C	-25 $^{\circ}$ C-16.5 $^{\circ}$ C	-25 $^{\circ}$ C-16.5 $^{\circ}$ C

Hi-FLEXi S Series



HP		58HP	60HP	62HP	64HP	
Model	Model	AVWT-552HKSS	AVWT-570HKSS	AVWT-592HKSS	AVWT-612HKSS	
	Modules	AVWT-212HKSS	AVWT-190HKSS	AVWT-232HKSS	AVWT-232HKSS	
		AVWT-170HKSS	AVWT-190HKSS	AVWT-190HKSS	AVWT-190HKSS	
Power Supply		AC 3 ϕ , 380-415V/50/60Hz				
Cooling	Capacity	kW	161.5	168.0	174.0	180.0
		kBtu/h	551.0	573.3	593.7	614.3
	Power Input	kW	51.76	53.70	56.35	58.62
	EER	kW/kW	3.12	3.13	3.09	3.07
Heating	Capacity	kW	181.0	189.0	194.0	201.0
		kBtu/h	617.6	645.0	661.1	685.0
	Power Input	kW	56.42	59.61	61.43	64.33
	COP	kW/kW	3.21	3.17	3.16	3.12
Ventilation	Air Flow Rate	m ³ /min	696	801	763	830
	Fan Quantity		6	6	6	6
	Static Pressure	Pa	110	110	110	110
Sound	Sound Pressure Level	dB(A)	70	70	70	70
Compressor	Type	Enhanced Vapor Injection Scroll Compressor				
	Compressor Quantity	pcs	6	6	6	6
Refrigerant	Type	R410A				
	Pre-charged Quantity	kg	41.9	42.9	43.0	44.1
Weight	Net Weight	kg	1063	1083	1078	1092
	Gross Weight	kg	1138	1185	1163	1187
Dimensions	External(HxWxD)	mm	1730x (1210+1210+1350) x750	1730x (1350+1350+1350) x750	1730x (1210+1350+1350) x750	1730x (1350+1350+1350) x750
		mm	1930x (1275+1275+1420) x790	1930x (1420+1420+1420) x790	1930x (1275+1420+1420) x790	1930x (1420+1420+1420) x790
	Packing(HxWxD)	mm	1930x (1275+1275+1420) x790	1930x (1420+1420+1420) x790	1930x (1275+1420+1420) x790	1930x (1420+1420+1420) x790
		mm	1930x (1275+1275+1420) x790	1930x (1420+1420+1420) x790	1930x (1275+1420+1420) x790	1930x (1420+1420+1420) x790
Cabinet Color		Ivory White	Ivory White	Ivory White	Ivory White	
Ref. Piping	Gas	mm	ϕ 44.5	ϕ 44.5	ϕ 44.5	ϕ 44.5
		inch	1-3/4	1-3/4	1-3/4	1-3/4
	Liquid	mm	ϕ 22.2	ϕ 22.2	ϕ 22.2	ϕ 22.2
		inch	7/8	7/8	7/8	7/8
Connectable Indoor Units	Quantity	pcs	64	64	64	64
	Total Capacity	-	50%-150%	50%-150%	50%-150%	50%-150%
Piping Design	Height Difference Between ODU and IDU	m(above)	50 (90 ^{**})	50 (90 ^{**})	50 (90 ^{**})	50 (90 ^{**})
		m(below)	40 (90 ^{**})	40 (90 ^{**})	40 (90 ^{**})	40 (90 ^{**})
	Height Difference Between IDUs	m	15 (30 ^{**})	15 (30 ^{**})	15 (30 ^{**})	15 (30 ^{**})
	Max. Piping Length	m	165	165	165	165
Operation Range	Cooling	DB	-5 $^{\circ}$ C-52 $^{\circ}$ C	-5 $^{\circ}$ C-52 $^{\circ}$ C	-5 $^{\circ}$ C-52 $^{\circ}$ C	-5 $^{\circ}$ C-52 $^{\circ}$ C
	Heating	WB	-25 $^{\circ}$ C-16.5 $^{\circ}$ C	-25 $^{\circ}$ C-16.5 $^{\circ}$ C	-25 $^{\circ}$ C-16.5 $^{\circ}$ C	-25 $^{\circ}$ C-16.5 $^{\circ}$ C

Hi-FLEXi S Series



HP		66HP	68HP	70HP	72HP	
Model	Model	AVWT-634HKSS	AVWT-654HKSS	AVWT-676HKSS	AVWT-696HKSS	
	Modules	AVWT-232HKSS	AVWT-232HKSS	AVWT-232HKSS	AVWT-232HKSS	
		AVWT-212HKSS	AVWT-232HKSS	AVWT-232HKSS	AVWT-232HKSS	
Power Supply		AC 3 ϕ , 380-415V/50/60Hz				
Cooling	Capacity	kW	185.5	192.0	197.5	204.0
		kBtu/h	633.0	655.3	674.0	696.3
	Power Input	kW	61.22	63.54	66.14	68.46
	EER	kW/kW	3.03	3.02	2.99	2.98
Heating	Capacity	kW	207.0	213.0	219.0	225.0
		kBtu/h	705.4	725.0	745.4	765.0
	Power Input	kW	66.94	69.05	71.66	73.77
	COP	kW/kW	3.09	3.08	3.06	3.05
Ventilation	Air Flow Rate	m ³ /min	859	859	888	888
	Fan Quantity		6	6	6	6
	Static Pressure	Pa	110	110	110	110
Sound	Sound Pressure Level	dB(A)	70	70	70	71
Compressor	Type	Enhanced Vapor Injection Scroll Compressor				
	Compressor Quantity	pcs	6	6	6	6
Refrigerant	Type	R410A				
	Pre-charged Quantity	kg	45.3	45.3	46.5	46.5
Weight	Net Weight	kg	1100	1101	1109	1110
	Gross Weight	kg	1188	1189	1190	1191
Dimensions	External(HxWxD)	mm	1730x (1350+1350+1350) x750	1730x (1350+1350+1350) x750	1730x (1350+1350+1350) x750	1730x (1350+1350+1350) x750
		mm	1930x (1420+1420+1420) x790	1930x (1420+1420+1420) x790	1930x (1420+1420+1420) x790	1930x (1420+1420+1420) x790
	Packing(HxWxD)	mm	1930x (1420+1420+1420) x790	1930x (1420+1420+1420) x790	1930x (1420+1420+1420) x790	1930x (1420+1420+1420) x790
		mm	1930x (1420+1420+1420) x790	1930x (1420+1420+1420) x790	1930x (1420+1420+1420) x790	1930x (1420+1420+1420) x790
Cabinet Color		Ivory White	Ivory White	Ivory White	Ivory White	
Ref. Piping	Gas	mm	ϕ 44.5	ϕ 50.8	ϕ 50.8	ϕ 50.8
		inch	1-3/4	2	2	2
	Liquid	mm	ϕ 22.2	ϕ 25.4	ϕ 25.4	ϕ 25.4
		inch	7/8	1	1	1
Connectable Indoor Units	Quantity	pcs	64	64	64	64
	Total Capacity	-	50%-150%	50%-150%	50%-150%	50%-150%
Piping Design	Height Difference Between ODU and IDU	m(above)	50 (90 ^{**})	50 (90 ^{**})	50 (90 ^{**})	50 (90 ^{**})
		m(below)	40 (90 ^{**})	40 (90 ^{**})	40 (90 ^{**})	40 (90 ^{**})
	Height Difference Between IDUs	m	15 (30 ^{**})	15 (30 ^{**})	15 (30 ^{**})	15 (30 ^{**})
	Max. Piping Length	m	165	165	165	165
Operation Range	Cooling	DB	-5 $^{\circ}$ C-52 $^{\circ}$ C	-5 $^{\circ}$ C-52 $^{\circ}$ C	-5 $^{\circ}$ C-52 $^{\circ}$ C	-5 $^{\circ}$ C-52 $^{\circ}$ C
	Heating	WB	-25 $^{\circ}$ C-16.5 $^{\circ}$ C	-25 $^{\circ}$ C-16.5 $^{\circ}$ C	-25 $^{\circ}$ C-16.5 $^{\circ}$ C	-25 $^{\circ}$ C-16.5 $^{\circ}$ C

Hi-FLEXi S Series



HP		74HP	76HP	78HP	80HP	
Model	Model	AVWT-714HKSS	AVWT-732HKSS	AVWT-754HKSS	AVWT-776HKSS	
	Modules	AVWT-250HKSS	AVWT-250HKSS	AVWT-272HKSS	AVWT-272HKSS	
		AVWT-232HKSS	AVWT-250HKSS	AVWT-250HKSS	AVWT-272HKSS	
Power Supply		AC 3 ϕ , 380-415V/50/60Hz				
Cooling	Capacity	kW	208.5	213.0	220.5	228.0
		kBtu/h	710.7	725.1	750.6	776.1
	Power Input	kW	70.22	71.98	74.99	78.00
	EER	kW/kW	2.97	2.96	2.95	2.92
Heating	Capacity	kW	230.0	235.0	245.0	255.0
		kBtu/h	782.0	799.0	833.0	867.0
	Power Input	kW	75.85	77.93	81.67	85.41
	COP	kW/kW	3.03	3.02	3.00	2.98
Ventilation	Air Flow Rate	m ³ /min	942	996	996	996
	Fan Quantity		6	6	6	6
	Static Pressure	Pa	110	110	110	110
Sound	Sound Pressure Level	dB(A)	71	71	71	71
Compressor	Type	Enhanced Vapor Injection Scroll Compressor				
	Compressor Quantity	pcs	6	6	6	6
Refrigerant	Type	R410A				
	Pre-charged Quantity	kg	48.3	50.1	50.1	50.1
Weight	Net Weight	kg	1154	1198	1199	1200
	Gross Weight	kg	1240	1289	1290	1291
Dimensions	External(HxWxD)	mm	(1350+1350+1600)	(1350+1600+1600)	(1350+1600+1600)	(1350+1600+1600)
			x750	x750	x750	x750
	Packing(HxWxD)	mm	1930x	1930x	1930x	1930x
			(1420+1420+1665)	(1420+1665+1665)	(1420+1665+1665)	(1420+1665+1665)
Cabinet Color		Ivory White	Ivory White	Ivory White	Ivory White	
Ref. Piping	Gas	mm	ϕ 50.8	ϕ 50.8	ϕ 50.8	ϕ 50.8
		inch	2	2	2	2
	Liquid	mm	ϕ 25.4	ϕ 25.4	ϕ 25.4	ϕ 25.4
		inch	1	1	1	1
Connectable Indoor Units	Quantity	pcs	64	64	64	64
	Total Capacity	-	50%-150%	50%-150%	50%-150%	50%-150%
Piping Design	Height Difference Between ODU and IDU	m(above)	50 (90 ^{**})	50 (90 ^{**})	50 (90 ^{**})	50 (90 ^{**})
		m(below)	40 (90 ^{**})	40 (90 ^{**})	40 (90 ^{**})	40 (90 ^{**})
	Height Difference Between IDUs	m	15 (30 ^{**})	15 (30 ^{**})	15 (30 ^{**})	15 (30 ^{**})
	Max. Piping Length	m	165	165	165	165
Operation Range	Cooling	DB	-5 $^{\circ}$ C-52 $^{\circ}$ C	-5 $^{\circ}$ C-52 $^{\circ}$ C	-5 $^{\circ}$ C-52 $^{\circ}$ C	-5 $^{\circ}$ C-52 $^{\circ}$ C
	Heating	WB	-25 $^{\circ}$ C-16.5 $^{\circ}$ C	-25 $^{\circ}$ C-16.5 $^{\circ}$ C	-25 $^{\circ}$ C-16.5 $^{\circ}$ C	-25 $^{\circ}$ C-16.5 $^{\circ}$ C

Hi-FLEXi S Series



HP		82HP	84HP	86HP	88HP	
Model	Model	AVWT-794HKSS	AVWT-816HKSS	AVWT-824HKSS	AVWT-844HKSS	
	Modules	AVWT-272HKSS	AVWT-272HKSS	AVWT-232HKSS	AVWT-232HKSS	
		AVWT-272HKSS	AVWT-272HKSS	AVWT-190HKSS	AVWT-190HKSS	
Power Supply		AC 3 ϕ , 380-415V/50/60Hz				
Cooling	Capacity	kW	232.5	240.0	241.5	248.0
		kBtu/h	790.5	816.0	824.1	846.4
	Power Input	kW	79.76	82.77	79.12	81.44
	EER	kW/kW	2.91	2.90	3.05	3.05
Heating	Capacity	kW	260.0	270.0	270.0	276.0
		kBtu/h	884.0	918.0	920.4	940.0
	Power Input	kW	87.49	91.23	86.81	88.92
	COP	kW/kW	2.97	2.96	3.11	3.10
Ventilation	Air Flow Rate	m ³ /min	1050	1050	1126	1126
	Fan Quantity		6	6	8	8
	Static Pressure	Pa	110	110	110	110
Sound	Sound Pressure Level	dB(A)	72	72	72	72
Compressor	Type	Enhanced Vapor Injection Scroll Compressor				
	Compressor Quantity	pcs	6	6	8	8
Refrigerant	Type	R410A				
	Pre-charged Quantity	kg	51.9	51.9	59.6	59.6
Weight	Net Weight	kg	1244	1245	1461	1462
	Gross Weight	kg	1340	1341	1583	1584
Dimensions	External(HxWxD)	mm	(1600+1600+1600)	(1600+1600+1600)	(1350+1350+1350+1350)	(1350+1350+1350+1350)
			x750	x750	x750	x750
	Packing(HxWxD)	mm	1930x	1930x	1930x	1930x
			(1665+1665+1665)	(1665+1665+1665)	(1420+1420+1420+1420)	(1420+1420+1420+1420)
Cabinet Color		Ivory White	Ivory White	Ivory White	Ivory White	
Ref. Piping	Gas	mm	ϕ 50.8	ϕ 50.8	ϕ 50.8	ϕ 50.8
		inch	2	2	2	2
	Liquid	mm	ϕ 25.4	ϕ 25.4	ϕ 25.4	ϕ 25.4
		inch	1	1	1	1
Connectable Indoor Units	Quantity	pcs	64	64	64	64
	Total Capacity	-	50%-150%	50%-150%	50%-150%	50%-150%
Piping Design	Height Difference Between ODU and IDU	m(above)	50 (90 ^{**})	50 (90 ^{**})	50 (90 ^{**})	50 (90 ^{**})
		m(below)	40 (90 ^{**})	40 (90 ^{**})	40 (90 ^{**})	40 (90 ^{**})
	Height Difference Between IDUs	m	15 (30 ^{**})	15 (30 ^{**})	15 (30 ^{**})	15 (30 ^{**})
	Max. Piping Length	m	165	165	165	165
Operation Range	Cooling	DB	-5 $^{\circ}$ C-52 $^{\circ}$ C	-5 $^{\circ}$ C-52 $^{\circ}$ C	-5 $^{\circ}$ C-52 $^{\circ}$ C	-5 $^{\circ}$ C-52 $^{\circ}$ C
	Heating	WB	-25 $^{\circ}$ C-16.5 $^{\circ}$ C	-25 $^{\circ}$ C-16.5 $^{\circ}$ C	-25 $^{\circ}$ C-16.5 $^{\circ}$ C	-25 $^{\circ}$ C-16.5 $^{\circ}$ C

Hi-FLEXi S Series



HP		90HP	92HP	94HP	96HP	
Model	Model	AVWT-866HKSS	AVWT-886HKSS	AVWT-908HKSS	AVWT-928HKSS	
	Modules	AVWT-232HKSS	AVWT-232HKSS	AVWT-232HKSS	AVWT-232HKSS	
		AVWT-232HKSS	AVWT-232HKSS	AVWT-232HKSS	AVWT-232HKSS	
		AVWT-212HKSS	AVWT-232HKSS	AVWT-232HKSS	AVWT-232HKSS	
		AVWT-190HKSS	AVWT-190HKSS	AVWT-212HKSS	AVWT-232HKSS	
Power Supply	AC 3 ϕ , 380-415V/50/60Hz					
Cooling	Capacity	kW	253.5	260.0	265.5	272.0
		kBtu/h	865.1	887.4	906.1	928.4
	Power Input	kW	84.04	86.36	88.96	91.28
	EER	kW/kW	3.02	3.01	2.98	2.98
Heating	Capacity	kW	282.0	288.0	294.0	300.0
		kBtu/h	960.4	980.0	1000.4	1020.0
	Power Input	kW	91.53	93.64	96.25	98.36
	COP	kW/kW	3.08	3.08	3.05	3.05
Ventilation	Air Flow Rate	m ³ /min	1155	1155	1184	1184
	Fan Quantity		8	8	8	8
	Static Pressure	Pa	110	110	110	110
Sound	Sound Pressure Level	dB(A)	72	72	72	72
Compressor	Type	Enhanced Vapor Injection Scroll Compressor				
	Compressor Quantity	pcs	8	8	8	8
Refrigerant	Type	R410A				
	Pre-charged Quantity	kg	60.8	60.8	62.0	62.0
Weight	Net Weight	kg	1470	1471	1479	1480
	Gross Weight	kg	1585	1586	1587	1588
Dimensions	External(HxWxD)	mm	(1350+1350+1350+1350) x750	(1350+1350+1350+1350) x750	(1350+1350+1350+1350) x750	(1350+1350+1350+1350) x750
		mm	1930x x790	1930x x790	1930x x790	1930x x790
	Packing(HxWxD)	mm	(1420+1420+1420+1420) x790	(1420+1420+1420+1420) x790	(1420+1420+1420+1420) x790	(1420+1420+1420+1420) x790
		mm				
Cabinet Color		Ivory White	Ivory White	Ivory White	Ivory White	
Ref. Piping	Gas	mm	ϕ 50.8	ϕ 50.8	ϕ 50.8	ϕ 50.8
		inch	2	2	2	2
	Liquid	mm	ϕ 25.4	ϕ 25.4	ϕ 25.4	ϕ 25.4
		inch	1	1	1	1
Connectable Indoor Units	Quantity	pcs	64	64	64	64
	Total Capacity	-	50%-150%	50%-150%	50%-150%	50%-150%
Piping Design	Height Difference Between ODU and IDU	m(above)	50 (90 ^{**})	50 (90 ^{**})	50 (90 ^{**})	50 (90 ^{**})
		m(below)	40 (90 ^{**})	40 (90 ^{**})	40 (90 ^{**})	40 (90 ^{**})
	Height Difference Between IDUs	m	15 (30 ^{**})	15 (30 ^{**})	15 (30 ^{**})	15 (30 ^{**})
		Max. Piping Length	m	165	165	165
Operation Range	Cooling	DB	-5 $^{\circ}$ C-52 $^{\circ}$ C	-5 $^{\circ}$ C-52 $^{\circ}$ C	-5 $^{\circ}$ C-52 $^{\circ}$ C	-5 $^{\circ}$ C-52 $^{\circ}$ C
	Heating	WB	-25 $^{\circ}$ C-16.5 $^{\circ}$ C	-25 $^{\circ}$ C-16.5 $^{\circ}$ C	-25 $^{\circ}$ C-16.5 $^{\circ}$ C	-25 $^{\circ}$ C-16.5 $^{\circ}$ C

Hi-FLEXi S Series



HP		98HP	100HP	102HP	104HP	
Model	Model	AVWT-946HKSS	AVWT-968HKSS	AVWT-988HKSS	AVWT-1008HKSS	
	Modules	AVWT-250HKSS	AVWT-272HKSS	AVWT-272HKSS	AVWT-272HKSS	
		AVWT-232HKSS	AVWT-232HKSS	AVWT-232HKSS	AVWT-232HKSS	
		AVWT-232HKSS	AVWT-232HKSS	AVWT-232HKSS	AVWT-232HKSS	
		AVWT-232HKSS	AVWT-232HKSS	AVWT-212HKSS	AVWT-232HKSS	
Power Supply	AC 3 ϕ , 380-415V/50/60Hz					
Cooling	Capacity	kW	276.5	284.0	289.5	296.0
		kBtu/h	942.8	968.3	985.9	1008.0
	Power Input	kW	93.04	96.05	98.50	100.82
	EER	kW/kW	2.97	2.96	2.94	2.94
Heating	Capacity	kW	305.0	315.0	324.0	330.0
		kBtu/h	1037.0	1071.0	1102.4	1122.0
	Power Input	kW	100.44	104.18	107.89	110.00
	COP	kW/kW	3.04	3.02	3.00	3.00
Ventilation	Air Flow Rate	m ³ /min	1238	1238	1292	1292
	Fan Quantity		8	8	8	8
	Static Pressure	Pa	110	110	110	110
Sound	Sound Pressure Level	dB(A)	72	72	72	73
Compressor	Type	Enhanced Vapor Injection Scroll Compressor				
	Compressor Quantity	pcs	8	8	8	8
Refrigerant	Type	R410A				
	Pre-charged Quantity	kg	63.8	63.8	65.6	65.6
Weight	Net Weight	kg	1524	1525	1569	1570
	Gross Weight	kg	1637	1638	1687	1688
Dimensions	External(HxWxD)	mm	(1350+1350+1350+1600) x750	(1350+1350+1350+1600) x750	(1350+1350+1600+1600) x750	(1350+1350+1600+1600) x750
		mm	1930x x790	1930x x790	1930x x790	1930x x790
	Packing(HxWxD)	mm	(1420+1420+1420+1665) x790	(1420+1420+1420+1665) x790	(1420+1420+1665+1665) x790	(1420+1420+1665+1665) x790
		mm				
Cabinet Color		Ivory White	Ivory White	Ivory White	Ivory White	
Ref. Piping	Gas	mm	ϕ 50.8	ϕ 50.8	ϕ 50.8	ϕ 50.8
		inch	2	2	2	2
	Liquid	mm	ϕ 25.4	ϕ 25.4	ϕ 25.4	ϕ 25.4
		inch	1	1	1	1
Connectable Indoor Units	Quantity	pcs	64	64	64	64
	Total Capacity	-	50%-150%	50%-150%	50%-150%	50%-150%
Piping Design	Height Difference Between ODU and IDU	m(above)	50 (90 ^{**})	50 (90 ^{**})	50 (90 ^{**})	50 (90 ^{**})
		m(below)	40 (90 ^{**})	40 (90 ^{**})	40 (90 ^{**})	40 (90 ^{**})
	Height Difference Between IDUs	m	15 (30 ^{**})	15 (30 ^{**})	15 (30 ^{**})	15 (30 ^{**})
		Max. Piping Length	m	165	165	165
Operation Range	Cooling	DB	-5 $^{\circ}$ C-52 $^{\circ}$ C	-5 $^{\circ}$ C-52 $^{\circ}$ C	-5 $^{\circ}$ C-52 $^{\circ}$ C	-5 $^{\circ}$ C-52 $^{\circ}$ C
	Heating	WB	-25 $^{\circ}$ C-16.5 $^{\circ}$ C	-25 $^{\circ}$ C-16.5 $^{\circ}$ C	-25 $^{\circ}$ C-16.5 $^{\circ}$ C	-25 $^{\circ}$ C-16.5 $^{\circ}$ C

Hi-FLEXi S Series



HP		106HP	108HP	110HP	112HP	
Model	Model	AVWT-1026HKSS	AVWT-1048HKSS	AVWT-1066HKSS	AVWT-1088HKSS	
	Modules	AVWT-272HKSS	AVWT-272HKSS	AVWT-272HKSS	AVWT-272HKSS	
		AVWT-272HKSS	AVWT-272HKSS	AVWT-272HKSS	AVWT-272HKSS	
		AVWT-250HKSS	AVWT-272HKSS	AVWT-272HKSS	AVWT-272HKSS	
	AVWT-232HKSS	AVWT-232HKSS	AVWT-250HKSS	AVWT-272HKSS		
Power Supply		AC 3 ϕ , 380-415V/50/60Hz				
Cooling	Capacity	kW	300.5	308.0	312.5	320.0
		kBtu/h	1022.6	1048.1	1062.5	1088.0
	Power Input	kW	102.58	105.59	107.35	110.36
	EER	kW/kW	2.93	2.92	2.91	2.90
Heating	Capacity	kW	335.0	345.0	350.0	360.0
		kBtu/h	1139.0	1173.0	1190.0	1224.0
	Power Input	kW	112.08	115.82	117.9	121.64
	COP	kW/kW	2.99	2.98	2.97	2.96
Ventilation	Air Flow Rate	m ³ /min	1346	1346	1400	1400
	Fan Quantity		8	8	8	8
	Static Pressure	Pa	110	110	110	110
Sound	Sound Pressure Level	dB(A)	73	73	73	73
Compressor	Type	Enhanced Vapor Injection Scroll Compressor				
	Compressor Quantity	pcs	8	8	8	8
Refrigerant	Type	R410A				
	Pre-charged Quantity	kg	67.4	67.4	69.2	69.2
Weight	Net Weight	kg	1614	1615	1659	1660
	Gross Weight	kg	1737	1738	1787	1788
Dimensions	External(HxWxD)	mm	(1350+1600+1600+1600)	(1350+1600+1600+1600)	(1600+1600+1600+1600)	(1600+1600+1600+1600)
			x750	x750	x750	x750
	Packing(HxWxD)	mm	(1420+1665+1665+1665)	(1420+1665+1665+1665)	(1665+1665+1665+1665)	(1665+1665+1665+1665)
			x790	x790	x790	x790
Cabinet Color		Ivory White	Ivory White	Ivory White	Ivory White	
Ref. Piping	Gas	mm	ϕ 50.8	ϕ 50.8	ϕ 50.8	ϕ 50.8
		inch	2	2	2	2
	Liquid	mm	ϕ 25.4	ϕ 25.4	ϕ 25.4	ϕ 25.4
		inch	1	1	1	1
Connectable Indoor Units	Quantity	pcs	64	64	64	64
	Total Capacity	-	50%-150%	50%-150%	50%-150%	50%-150%
Piping Design	Height Difference Between ODU and IDU	m(above)	50 (90 ^{**})	50 (90 ^{**})	50 (90 ^{**})	50 (90 ^{**})
		m(below)	40 (90 ^{**})	40 (90 ^{**})	40 (90 ^{**})	40 (90 ^{**})
	Height Difference Between IDUs	m	15 (30 ^{**})	15 (30 ^{**})	15 (30 ^{**})	15 (30 ^{**})
	Max. Piping Length	m	165	165	165	165
Operation Range	Cooling	DB	-5 $^{\circ}$ C-52 $^{\circ}$ C	-5 $^{\circ}$ C-52 $^{\circ}$ C	-5 $^{\circ}$ C-52 $^{\circ}$ C	-5 $^{\circ}$ C-52 $^{\circ}$ C
	Heating	WB	-25 $^{\circ}$ C-16.5 $^{\circ}$ C	-25 $^{\circ}$ C-16.5 $^{\circ}$ C	-25 $^{\circ}$ C-16.5 $^{\circ}$ C	-25 $^{\circ}$ C-16.5 $^{\circ}$ C

NOTES:

1. Rated cooling capacity and rated heating capacity are tested in the following conditions:

Cooling conditions: indoor air inlet temperature: 27 $^{\circ}$ C DB 19 $^{\circ}$ C WB, outdoor air inlet temperature: 35 $^{\circ}$ C DB, pipe length: 7.5m, pipe height difference: 0m.

Heating conditions: indoor air inlet temperature: 20 $^{\circ}$ C DB, outdoor air inlet temperature: 7 $^{\circ}$ C DB 6 $^{\circ}$ C WB, pipe length: 7.5m, pipe height difference: 0m.

2. The above noise values are measured in the anechoic chamber without reflected echo, therefore the impact of the reflected echo must be included at the scene.

3. The final appearance of outdoor units is subject to the actual products.

4. For height difference between ODU & IDU more than 50(40)m, please contact our professional engineer.

5. When the operation temperature is under 48 $^{\circ}$ C ~ 52 $^{\circ}$ C or -25 $^{\circ}$ C ~ -20 $^{\circ}$ C, please contact our professional engineer.

*1: For detailed information, please contact with Hisense's technical staff.

Hi-FLEXi S mavo+ Series



Extra Long Pipe Design

With extra long pipe, the height difference between the indoor unit and outdoor unit is up to 90 meters*, which makes installation more flexible.

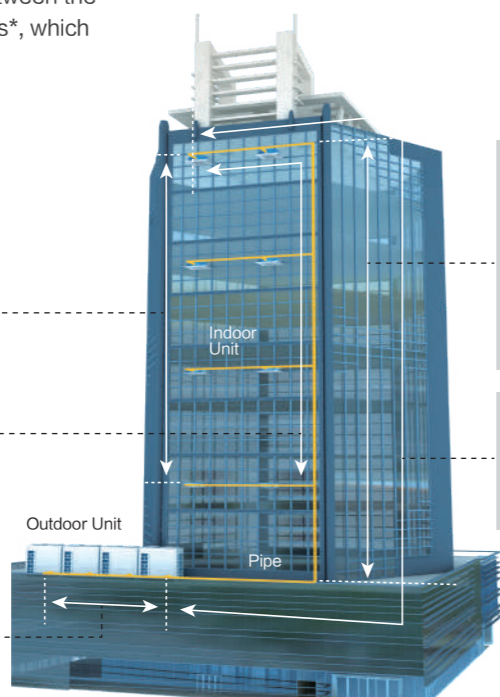

Maximum height difference between indoor and outdoor units:
 when the outdoor unit is above: 50m(90m*)
 when the outdoor unit is below: 40m(90m*)

Maximum length of a single pipe: 165m
 Total length of pipes: 1000m

Maximum height difference of indoor units: 30m

Maximum length from the first branch pipe to the farthest indoor unit: 90m

Largest pipe length between outdoor units: 10m

*Note: For detailed information, please contact Hisense's technical staff.

High-efficiency Compressor

Hi-FLEXi S mavo+ series adopts a new generation of scroll compressor, and it has an excellent mechanism called as FCM (Frame Compliant Mechanism) which will optimally increase the performance of the whole compressor, especially for operation under low load.

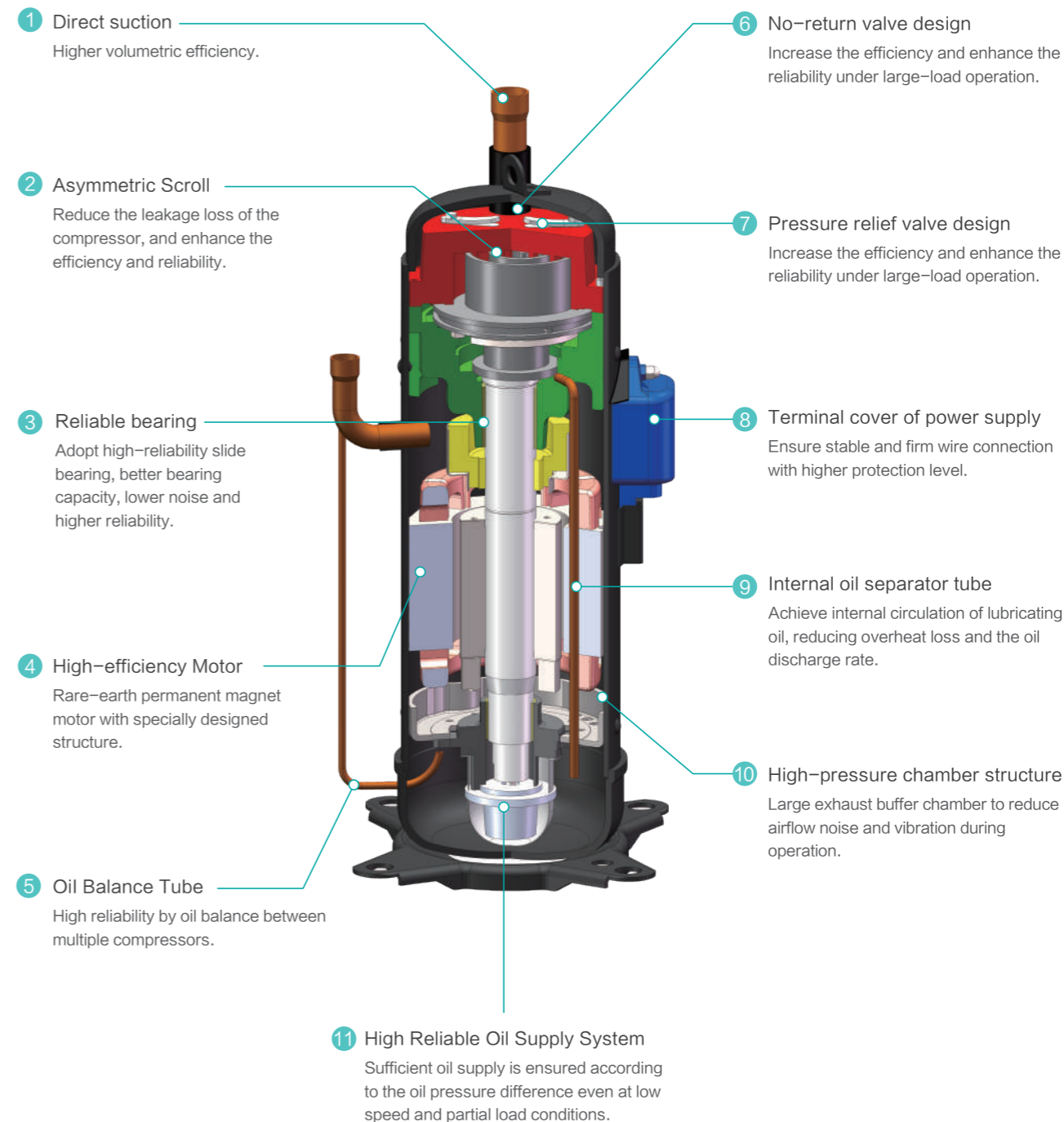

Hi-FLEXi S mavo+ Series



HP		8HP	10HP	12HP	14HP	16HP	18HP
Model	Model	AVWT-76HKFSEA	AVWT-96HKFSEA	AVWT-114HKFSEA	AVWT-136HKFSEA	AVWT-154HKFSEA	AVWT-170HKFSEA
	Modules	—	—	—	—	—	—
Power Supply		AC 3 ϕ , 380-415V/50/60Hz					
Cooling	Capacity	kW	22.4	28.0	33.5	40.0	45.0
		kBtu/h	76.4	95.5	114.3	136.5	153.5
	Power Input	kW	4.79	6.60	7.96	10.34	12.26
	EER	kW/kW	4.68	4.24	4.21	3.87	3.67
Heating	Capacity	kW	25.0	31.5	37.5	45.0	50.0
		kBtu/h	85.3	107.5	128.0	153.5	170.6
	Power Input	kW	5.13	6.79	8.50	10.84	12.20
	COP	kW/kW	4.87	4.64	4.41	4.15	4.10
Ventilation	Air Flow Rate	m ³ /min	183	183	183	200	200
	Fan Quantity		1	1	1	2	2
	Static Pressure	Pa	110	110	110	110	110
Sound Pressure Level	Normal Mode	dB(A)	56	57	59	59	61
	Night Shift Mode	dB(A)	41	42	44	44	46
Compressor	Type	Scroll Compressor					
	Compressor Quantity	pcs	1	1	1	1	1
Refrigerant	Type	R410A					
	Pre-charged Quantity	kg	5.3	5.3	6.2	8.0	8.0
Weight	Net Weight	kg	217	219	223	272	296
	Gross Weight	kg	246	248	252	306	307
Dimensions	External(HxWxD)	mm	1730x950x750	1730x950x750	1730x950x750	1730x1210x750	1730x1210x750
	Packing(HxWxD)	mm	1950x1015x790	1950x1015x790	1950x1015x790	1950x1275x790	1950x1275x790
Cabinet Color			Ivory White	Ivory White	Ivory White	Ivory White	Ivory White
Ref. Piping	Gas	mm	ϕ 19.05	ϕ 22.20	ϕ 25.40	ϕ 25.40	ϕ 28.60
		inch	3/4	7/8	1	1	1-1/8
	Liquid	mm	ϕ 9.53	ϕ 9.53	ϕ 12.70	ϕ 12.70	ϕ 12.70
		inch	3/8	3/8	1/2	1/2	1/2
Connectable Indoor Units	Quantity	pcs	13	16	19	23	26
	Total Capacity	—	50%-150%	50%-150%	50%-150%	50%-150%	50%-150%
Piping Design	Height Difference Between ODU and IDU	m(above)	50(90 ^{**})	50(90 ^{**})	50(90 ^{**})	50(90 ^{**})	50(90 ^{**})
		m(below)	40(90 ^{**})	40(90 ^{**})	40(90 ^{**})	40(90 ^{**})	40(90 ^{**})
	Height Difference Between IDUs	m	30	30	30	30	30
	Max. Piping Length	m	1000	1000	1000	1000	1000
Operation Range ^{**}	Cooling	DB	-5 $^{\circ}$ C-52 $^{\circ}$ C	-5 $^{\circ}$ C-52 $^{\circ}$ C	-5 $^{\circ}$ C-52 $^{\circ}$ C	-5 $^{\circ}$ C-52 $^{\circ}$ C	-5 $^{\circ}$ C-52 $^{\circ}$ C
	Heating	WB	-25 $^{\circ}$ C-16.5 $^{\circ}$ C	-25 $^{\circ}$ C-16.5 $^{\circ}$ C	-25 $^{\circ}$ C-16.5 $^{\circ}$ C	-25 $^{\circ}$ C-16.5 $^{\circ}$ C	-25 $^{\circ}$ C-16.5 $^{\circ}$ C

Hi-FLEXi S mavo+ Series



HP		20HP	22HP	24HP	26HP	28HP
Model	Model	AVWT-190HKFSEA	AVWT-212HKFSEA	AVWT-232HKFSEA	AVWT-250HKFSEA	AVWT-272HKFSEA
	Modules	—	—	—	—	—
Power Supply		AC 3 ϕ , 380-415V/50/60Hz				
Cooling	Capacity	kW	56.0	61.5	68.0	72.5
		kBtu/h	191.1	209.8	232.0	247.4
	Power Input	kW	15.38	17.83	19.88	20.83
	EER	kW/kW	3.64	3.45	3.42	3.48
Heating	Capacity	kW	63.0	69.0	75.0	80.0
		kBtu/h	215.0	235.4	255.9	273.0
	Power Input	kW	16.36	18.70	20.72	21.98
	COP	kW/kW	3.85	3.69	3.62	3.64
Ventilation	Air Flow Rate	m ³ /min	267	296	296	350
	Fan Quantity		2	2	2	2
	Static Pressure	Pa	110	110	110	110
Sound Pressure Level	Normal Mode	dB(A)	62	63	63	64
	Night Shift Mode	dB(A)	47	48	48	49
Compressor	Type	Scroll Compressor				
	Compressor Quantity	pcs	1	2	2	2
Refrigerant	Type	R410A				
	Pre-charged Quantity	kg	10.3	12.2	12.2	12.0
Weight	Net Weight	kg	316	363	365	391
	Gross Weight	kg	347	400	402	433
Dimensions	External(HxWxD)	mm	1730x1350x750	1730x1350x750	1730x1350x750	1730x1600x750
	Packing(HxWxD)	mm	1950x1420x790	1950x1420x790	1950x1420x790	1950x1665x790
Cabinet Color			Ivory White	Ivory White	Ivory White	Ivory White
Ref. Piping	Gas	mm	ϕ 28.60	ϕ 28.60	ϕ 28.60	ϕ 31.75
		inch	1-1/8	1-1/8	1-1/8	1-1/4
	Liquid	mm	ϕ 15.88	ϕ 15.88	ϕ 15.88	ϕ 19.05
		inch	5/8	5/8	5/8	3/4
Connectable Indoor Units	Quantity	pcs	33	36	40	43
	Total Capacity	—	50%-150%	50%-150%	50%-150%	50%-150%
Piping Design	Height Difference Between ODU and IDU	m(above)	50(90 ^{**})	50(90 ^{**})	50(90 ^{**})	50(90 ^{**})
		m(below)	40(90 ^{**})	40(90 ^{**})	40(90 ^{**})	40(90 ^{**})
	Height Difference Between IDUs	m	30	30	30	30
	Max. Piping Length	m	1000	1000	1000	1000
Operation Range ^{**}	Cooling	DB	-5 $^{\circ}$ C-52 $^{\circ}$ C	-5 $^{\circ}$ C-52 $^{\circ}$ C	-5 $^{\circ}$ C-52 $^{\circ}$ C	-5 $^{\circ}$ C-52 $^{\circ}$ C
	Heating	WB	-25 $^{\circ}$ C-16.5 $^{\circ}$ C	-25 $^{\circ}$ C-16.5 $^{\circ}$ C	-25 $^{\circ}$ C-16.5 $^{\circ}$ C	-25 $^{\circ}$ C-16.5 $^{\circ}$ C

Hi-FLEXi S mavo+ Series



HP		30HP	32HP	34HP	36HP
Model	Model	AVWT-290HKFSEA	AVWT-308HKFSEA	AVWT-324HKFSEA	AVWT-340HKFSEA
	Modules	AVWT-136HKFSEA AVWT-154HKFSEA	AVWT-154HKFSEA AVWT-154HKFSEA	AVWT-154HKFSEA AVWT-170HKFSEA	AVWT-170HKFSEA AVWT-170HKFSEA
Power Supply		AC 3 ϕ , 380-415V/50/60Hz			
Cooling	Capacity	kW 85.0	90.0	95.0	100.0
		kBtu/h 290.0	308.0	324.0	342.0
	Power Input	kW 22.60	24.52	26.31	28.09
	EER	kW/kW 3.76	3.67	3.61	3.56
Heating	Capacity	kW 95.0	100.0	106.0	112.0
		kBtu/h 324.0	342.0	362.0	382.0
	Power Input	kW 23.04	24.39	27.01	29.63
	COP	kW/kW 4.12	4.10	3.92	3.78
Ventilation	Air Flow Rate	m ³ /min 400	400	400	400
	Fan Quantity	4	4	4	4
	Static Pressure	Pa 110	110	110	110
Sound Pressure Level	Normal Mode	dB(A) 64	64	64	64
	Night Shift Mode	dB(A) 49	49	49	49
Compressor	Type	Scroll Compressor			
	Compressor Quantity	pcs 2	2	2	2
Refrigerant	Type	R410A			
	Pre-charged Quantity	kg 8.0+8.0	8.0+8.0	8.0+9.6	9.6+9.6
Weight	Net Weight	kg 272+273	273+273	273+296	296+296
	Gross Weight	kg 306+307	307+307	307+330	330+330
Dimensions	External(HxWxD)	mm 1730x (1210+1210) x750	1730x (1210+1210) x750	1730x (1210+1210) x750	1730x (1210+1210) x750
		mm 1950x (1275+1275) x790	1950x (1275+1275) x790	1950x (1275+1275) x790	1950x (1275+1275) x790
	Packing(HxWxD)	mm 1730x (1210+1350) x750	1730x (1210+1350) x750	1730x (1210+1350) x750	1730x (1210+1350) x750
		mm 1950x (1275+1420) x790	1950x (1275+1420) x790	1950x (1275+1420) x790	1950x (1275+1420) x790
Cabinet Color		Ivory White	Ivory White	Ivory White	Ivory White
Ref. Piping	Gas	mm ϕ 31.75	ϕ 31.75	ϕ 38.10	ϕ 38.10
		inch 1-1/4	1-1/4	1-1/2	1-1/2
	Liquid	mm ϕ 19.05	ϕ 19.05	ϕ 19.05	ϕ 19.05
		inch 3/4	3/4	3/4	3/4
Connectable Indoor Units	Quantity	pcs 49	52	55	59
	Total Capacity	- 50%-150%	50%-150%	50%-150%	50%-150%
Piping Design	Height Difference Between ODU and IDU	m(above) 50(90 ^{**})	50(90 ^{**})	50(90 ^{**})	50(90 ^{**})
		m(below) 40(90 ^{**})	40(90 ^{**})	40(90 ^{**})	40(90 ^{**})
	Height Difference Between IDUs	m 30	30	30	30
	Max. Piping Length	m 1000	1000	1000	1000
Operation Range ^{**}	Cooling	DB -5 $^{\circ}$ C-52 $^{\circ}$ C	-5 $^{\circ}$ C-52 $^{\circ}$ C	-5 $^{\circ}$ C-52 $^{\circ}$ C	-5 $^{\circ}$ C-52 $^{\circ}$ C
	Heating	WB -25 $^{\circ}$ C-16.5 $^{\circ}$ C	-25 $^{\circ}$ C-16.5 $^{\circ}$ C	-25 $^{\circ}$ C-16.5 $^{\circ}$ C	-25 $^{\circ}$ C-16.5 $^{\circ}$ C

Hi-FLEXi S mavo+ Series



HP		38HP	40HP	42HP	44HP	46HP
Model	Model	AVWT-360HKFSEA	AVWT-380HKFSEA	AVWT-402HKFSEA	AVWT-422HKFSEA	AVWT-444HKFSEA
	Modules	AVWT-170HKFSEA AVWT-190HKFSEA	AVWT-190HKFSEA AVWT-190HKFSEA	AVWT-170HKFSEA AVWT-232HKFSEA	AVWT-190HKFSEA AVWT-232HKFSEA	AVWT-212HKFSEA AVWT-232HKFSEA
Power Supply		AC 3 ϕ , 380-415V/50/60Hz				
Cooling	Capacity	kW 106.0	112.0	118.0	124.0	129.5
		kBtu/h 362.0	382.0	405.0	425.0	440.0
	Power Input	kW 29.43	30.77	33.93	35.27	37.71
	EER	kW/kW 3.60	3.64	3.48	3.52	3.43
Heating	Capacity	kW 119.0	126.0	131.0	138.0	144.0
		kBtu/h 405.0	430.0	445.0	470.0	490.0
	Power Input	kW 31.18	32.73	35.53	37.08	39.42
	COP	kW/kW 3.82	3.85	3.69	3.72	3.65
Ventilation	Air Flow Rate	m ³ /min 467	496	496	563	592
	Fan Quantity	4	4	4	4	4
	Static Pressure	Pa 110	110	110	110	110
Sound Pressure Level	Normal Mode	dB(A) 65	65	65	66	66
	Night Shift Mode	dB(A) 50	50	50	51	51
Compressor	Type	Scroll Compressor				
	Compressor Quantity	pcs 2	2	3	3	4
Refrigerant	Type	R410A				
	Pre-charged Quantity	kg 9.6+10.3	10.3+10.3	9.6+12.2	10.3+12.2	12.2+12.2
Weight	Net Weight	kg 296+316	316+316	296+365	316+365	363+365
	Gross Weight	kg 330+347	347+347	330+402	347+402	400+402
Dimensions	External(HxWxD)	mm 1730x (1210+1350) x750	1730x (1210+1350) x750	1730x (1210+1350) x750	1730x (1350+1350) x750	1730x (1350+1350) x750
		mm 1950x (1275+1420) x790	1950x (1275+1420) x790	1950x (1275+1420) x790	1950x (1420+1420) x790	1950x (1420+1420) x790
	Packing(HxWxD)	mm 1730x (1210+1350) x750	1730x (1210+1350) x750	1730x (1210+1350) x750	1730x (1350+1350) x750	1730x (1350+1350) x750
		mm 1950x (1275+1420) x790	1950x (1275+1420) x790	1950x (1275+1420) x790	1950x (1420+1420) x790	1950x (1420+1420) x790
Cabinet Color		Ivory White	Ivory White	Ivory White	Ivory White	Ivory White
Ref. Piping	Gas	mm ϕ 38.10	ϕ 38.10	ϕ 38.10	ϕ 38.10	ϕ 41.30
		inch 1-1/2	1-1/2	1-1/2	1-1/2	1-5/8
	Liquid	mm ϕ 19.05	ϕ 19.05	ϕ 19.05	ϕ 19.05	ϕ 22.20
		inch 3/4	3/4	3/4	3/4	7/8
Connectable Indoor Units	Quantity	pcs 62	64	64	64	64
	Total Capacity	- 50%-150%	50%-150%	50%-150%	50%-150%	50%-150%
Piping Design	Height Difference Between ODU and IDU	m(above) 50(90 ^{**})	50(90 ^{**})	50(90 ^{**})	50(90 ^{**})	50(90 ^{**})
		m(below) 40(90 ^{**})	40(90 ^{**})	40(90 ^{**})	40(90 ^{**})	40(90 ^{**})
	Height Difference Between IDUs	m 30	30	30	30	30
	Max. Piping Length	m 1000	1000	1000	1000	1000
Operation Range ^{**}	Cooling	DB -5 $^{\circ}$ C-52 $^{\circ}$ C	-5 $^{\circ}$ C-52 $^{\circ}$ C	-5 $^{\circ}$ C-52 $^{\circ}$ C	-5 $^{\circ}$ C-52 $^{\circ}$ C	-5 $^{\circ}$ C-52 $^{\circ}$ C
	Heating	WB -25 $^{\circ}$ C-16.5 $^{\circ}$ C	-25 $^{\circ}$ C-16.5 $^{\circ}$ C	-25 $^{\circ}$ C-16.5 $^{\circ}$ C	-25 $^{\circ}$ C-16.5 $^{\circ}$ C	-25 $^{\circ}$ C-16.5 $^{\circ}$ C

Hi-FLEXi S mavo+ Series



HP		48HP	50HP	52HP	54HP	56HP	
Model	Model	AVWT-464HKFSEA	AVWT-482HKFSEA	AVWT-504HKFSEA	AVWT-522HKFSEA	AVWT-544HKFSEA	
	Modules	AVWT-232HKFSEA AVWT-232HKFSEA	AVWT-232HKFSEA AVWT-250HKFSEA	AVWT-232HKFSEA AVWT-272HKFSEA	AVWT-250HKFSEA AVWT-272HKFSEA	AVWT-272HKFSEA AVWT-272HKFSEA	
Power Supply		AC 3Φ, 380-415V/50/60Hz					
Cooling	Capacity	kW	136.0	140.5	148.0	152.5	160.0
		kBtu/h	465.0	480.0	505.0	520.0	545.0
	Power Input	kW	39.77	40.72	43.98	44.93	48.19
	EER	kW/kW	3.42	3.45	3.37	3.39	3.32
Heating	Capacity	kW	150.0	155.0	165.0	170.0	180.0
		kBtu/h	510.0	530.0	565.0	580.0	615.0
	Power Input	kW	41.44	42.70	46.29	47.55	51.14
	COP	kW/kW	3.62	3.63	3.56	3.58	3.52
Ventilation	Air Flow Rate	m³/min	592	646	646	700	700
	Fan Quantity		4	4	4	4	4
	Static Pressure	Pa	110	110	110	110	110
Sound Pressure Level	Normal Mode	dB(A)	66	67	67	67	67
	Night Shift Mode	dB(A)	51	52	52	52	52
Compressor	Type	Scroll Compressor					
	Compressor Quantity	pcs	4	4	4	4	4
Refrigerant	Type	R410A					
	Pre-charged Quantity	kg	12.2+12.2	12.2+12.0	12.2+12.0	12.0+12.0	12.0+12.0
Weight	Net Weight	kg	365+365	365+391	365+392	391+392	392+392
	Gross Weight	kg	402+402	402+433	402+434	433+434	434+434
Dimensions	External(HxWxD)	mm	(1350+1350)	(1350+1600)	(1350+1600)	(1600+1600)	(1600+1600)
			x750	x750	x750	x750	x750
	Packing(HxWxD)	mm	1950x	1950x	1950x	1950x	1950x
			(1420+1420)	(1420+1665)	(1420+1665)	(1665+1665)	(1665+1665)
Cabinet Color		Ivory White	Ivory White	Ivory White	Ivory White	Ivory White	
Ref. Piping	Gas	mm	φ41.3	φ41.3	φ41.3	φ41.3	φ41.3
		inch	1-5/8	1-5/8	1-5/8	1-5/8	1-5/8
	Liquid	mm	φ22.2	φ22.2	φ22.2	φ22.2	φ22.2
		inch	7/8	7/8	7/8	7/8	7/8
Connectable Indoor Units	Quantity	pcs	64	64	64	64	64
	Total Capacity	-	50%-150%	50%-150%	50%-150%	50%-150%	50%-150%
Piping Design	Height Difference Between ODU and IDU	m(above)	50(90**)	50(90**)	50(90**)	50(90**)	50(90**)
		m(below)	40(90**)	40(90**)	40(90**)	40(90**)	40(90**)
	Height Difference Between IDUs	m	30	30	30	30	30
	Max. Piping Length	m	1000	1000	1000	1000	1000
Operation Range*2	Cooling	DB	-5°C-52°C	-5°C-52°C	-5°C-52°C	-5°C-52°C	-5°C-52°C
	Heating	WB	-25°C-16.5°C	-25°C-16.5°C	-25°C-16.5°C	-25°C-16.5°C	-25°C-16.5°C

Hi-FLEXi S mavo+ Series



HP		58HP	60HP	62HP	64HP	
Model	Model	AVWT-552HKFSEA	AVWT-572HKFSEA	AVWT-592HKFSEA	AVWT-612HKFSEA	
	Modules	AVWT-170HKFSEA AVWT-170HKFSEA AVWT-212HKFSEA	AVWT-170HKFSEA AVWT-170HKFSEA AVWT-232HKFSEA	AVWT-170HKFSEA AVWT-190HKFSEA AVWT-232HKFSEA	AVWT-190HKFSEA AVWT-190HKFSEA AVWT-232HKFSEA	
Power Supply		AC 3Φ, 380-415V/50/60Hz				
Cooling	Capacity	kW	161.5	168.0	174.0	180.0
		kBtu/h	550.0	575.0	595.0	615.0
	Power Input	kW	45.92	47.97	49.31	50.65
	EER	kW/kW	3.52	3.50	3.53	3.55
Heating	Capacity	kW	181.0	187.0	194.0	201.0
		kBtu/h	620.0	640.0	660.0	685.0
	Power Input	kW	48.33	50.35	51.90	53.45
	COP	kW/kW	3.75	3.71	3.74	3.76
Ventilation	Air Flow Rate	m³/min	696	696	763	792
	Fan Quantity		6	6	6	6
	Static Pressure	Pa	110	110	110	110
Sound Pressure Level	Normal Mode	dB(A)	67	67	67	67
	Night Shift Mode	dB(A)	52	52	52	52
Compressor	Type	Scroll Compressor				
	Compressor Quantity	pcs	4	4	4	4
Refrigerant	Type	R410A				
	Pre-charged Quantity	kg	9.6+9.6+12.2	9.6+9.6+12.2	9.6+10.3+12.2	10.3+10.3+12.2
Weight	Net Weight	kg	296+296+363	296+296+365	296+316+365	316+316+365
	Gross Weight	kg	330+330+400	330+330+402	330+347+402	347+347+402
Dimensions	External(HxWxD)	mm	(1210+1210+1350)	(1210+1210+1350)	(1210+1350+1350)	(1210+1350+1350)
			x750	x750	x750	x750
	Packing(HxWxD)	mm	1950x	1950x	1950x	1950x
			(1275+1275+1420)	(1275+1275+1420)	(1275+1420+1420)	(1275+1420+1420)
Cabinet Color		Ivory White	Ivory White	Ivory White	Ivory White	
Ref. Piping	Gas	mm	φ44.5	φ44.5	φ44.5	φ44.5
		inch	1-3/4	1-3/4	1-3/4	1-3/4
	Liquid	mm	φ22.2	φ22.2	φ22.2	φ22.2
		inch	7/8	7/8	7/8	7/8
Connectable Indoor Units	Quantity	pcs	64	64	64	64
	Total Capacity	-	50%-150%	50%-150%	50%-150%	50%-150%
Piping Design	Height Difference Between ODU and IDU	m(above)	50(90**)	50(90**)	50(90**)	50(90**)
		m(below)	40(90**)	40(90**)	40(90**)	40(90**)
	Height Difference Between IDUs	m	30	30	30	30
	Max. Piping Length	m	1000	1000	1000	1000
Operation Range*2	Cooling	DB	-5°C-52°C	-5°C-52°C	-5°C-52°C	-5°C-52°C
	Heating	WB	-25°C-16.5°C	-25°C-16.5°C	-25°C-16.5°C	-25°C-16.5°C

Hi-FLEXi S mavo+ Series



HP		66HP	68HP	70HP	72HP	74HP	
Model	Model	AVWT-634HKFSEA	AVWT-654HKFSEA	AVWT-676HKFSEA	AVWT-696HKFSEA	AVWT-714HKFSEA	
	Modules	AVWT-170HKFSEA	AVWT-190HKFSEA	AVWT-212HKFSEA	AVWT-232HKFSEA	AVWT-232HKFSEA	
		AVWT-232HKFSEA	AVWT-232HKFSEA	AVWT-232HKFSEA	AVWT-232HKFSEA	AVWT-250HKFSEA	
Power Supply		AC 3Φ, 380-415V/50/60Hz					
Cooling	Capacity	kW	186.0	192.0	197.5	204.0	208.5
		kBtu/h	635.0	655.0	675.0	695.0	710.0
	Power Input	kW	53.81	55.15	57.59	59.65	60.60
	EER	kW/kW	3.46	3.48	3.43	3.42	3.44
Heating	Capacity	kW	206.0	213.0	219.0	225.0	230.0
		kBtu/h	705.0	725.0	745.0	770.0	785.0
	Power Input	kW	56.25	57.80	60.14	62.15	63.41
	COP	kW/kW	3.66	3.69	3.64	3.63	3.63
Ventilation	Air Flow Rate	m³/min	792	859	888	888	942
	Fan Quantity		6	6	6	6	6
	Static Pressure	Pa	110	110	110	110	110
Sound Pressure Level	Normal Mode	dB(A)	67	67	68	68	68
	Night Shift Mode	dB(A)	52	52	53	53	53
Compressor	Type	Scroll Compressor					
	Compressor Quantity	pcs	5	5	6	6	6
Refrigerant	Type	R410A					
	Pre-charged Quantity	kg	9.6+12.2+12.2	10.3+12.2+12.2	12.2+12.2+12.2	12.2+12.2+12.2	12.2+12.2+12.0
Weight	Net Weight	kg	296+365+365	316+365+365	363+365+365	365+365+365	365+365+391
	Gross Weight	kg	330+402+402	347+402+402	400+402+402	402+402+402	402+402+433
Dimensions	External(HxWxD)	mm	1730x (1210+1350+1350)	1730x (1350+1350+1350)	1730x (1350+1350+1350)	1730x (1350+1350+1350)	1730x (1350+1350+1600)
			x750	x750	x750	x750	x750
	Packing(HxWxD)	mm	1950x (1275+1420+1420)	1950x (1420+1420+1420)	1950x (1420+1420+1420)	1950x (1420+1420+1420)	1950x (1420+1420+1665)
			x790	x790	x790	x790	x790
Cabinet Color		Ivory White	Ivory White	Ivory White	Ivory White	Ivory White	
Ref. Piping	Gas	mm	φ44.5	φ50.8	φ50.8	φ50.8	φ50.8
		inch	1-3/4	2	2	2	2
	Liquid	mm	φ22.2	φ25.4	φ25.4	φ25.4	φ25.4
		inch	7/8	1	1	1	1
Connectable Indoor Units	Quantity	pcs	64	64	64	64	64
	Total Capacity	-	50%-150%	50%-150%	50%-150%	50%-150%	50%-150%
Piping Design	Height Difference Between ODU and IDU	m(above)	50(90**)	50(90**)	50(90**)	50(90**)	50(90**)
		m(below)	40(90**)	40(90**)	40(90**)	40(90**)	40(90**)
	Height Difference Between IDUs	m	30	30	30	30	30
	Max. Piping Length	m	1000	1000	1000	1000	1000
Operation Range*2	Cooling	DB	-5°C-52°C	-5°C-52°C	-5°C-52°C	-5°C-52°C	-5°C-52°C
	Heating	WB	-25°C-16.5°C	-25°C-16.5°C	-25°C-16.5°C	-25°C-16.5°C	-25°C-16.5°C

Hi-FLEXi S mavo+ Series



HP		76HP	78HP	80HP	82HP	84HP	
Model	Model	AVWT-732HKFSEA	AVWT-754HKFSEA	AVWT-776HKFSEA	AVWT-794HKFSEA	AVWT-816HKFSEA	
	Modules	AVWT-232HKFSEA	AVWT-232HKFSEA	AVWT-272HKFSEA	AVWT-272HKFSEA	AVWT-272HKFSEA	
		AVWT-250HKFSEA	AVWT-250HKFSEA	AVWT-272HKFSEA	AVWT-272HKFSEA	AVWT-272HKFSEA	
Power Supply		AC 3Φ, 380-415V/50/60Hz					
Cooling	Capacity	kW	213.0	220.5	228.0	232.5	240.0
		kBtu/h	725.0	750.0	780.0	795.0	820.0
	Power Input	kW	61.55	64.81	68.08	69.03	72.29
	EER	kW/kW	3.46	3.40	3.35	3.37	3.32
Heating	Capacity	kW	235.0	245.0	255.0	260.0	270.0
		kBtu/h	800.0	835.0	870.0	885.0	920.0
	Power Input	kW	64.67	68.26	71.85	73.11	76.70
	COP	kW/kW	3.63	3.59	3.55	3.56	3.52
Ventilation	Air Flow Rate	m³/min	996	996	996	1050	1050
	Fan Quantity		6	6	6	6	6
	Static Pressure	Pa	110	110	110	110	110
Sound Pressure Level	Normal Mode	dB(A)	68	68	68	69	69
	Night Shift Mode	dB(A)	53	53	53	54	54
Compressor	Type	Scroll Compressor					
	Compressor Quantity	pcs	6	6	6	6	6
Refrigerant	Type	R410A					
	Pre-charged Quantity	kg	12.2+12.0+12.0	12.2+12.0+12.0	12.0+12.0+12.2	12.0+12.0+12.0	12.0+12.0+12.0
Weight	Net Weight	kg	365+391+391	365+391+392	392+392+365	392+392+391	392+392+392
	Gross Weight	kg	402+433+433	402+433+434	434+434+402	434+434+433	434+434+434
Dimensions	External(HxWxD)	mm	1730x (1350+1600+1600)	1730x (1350+1600+1600)	1730x (1600+1600+1350)	1730x (1600+1600+1600)	1730x (1600+1600+1600)
			x750	x750	x750	x750	x750
	Packing(HxWxD)	mm	1950x (1420+1665+1665)	1950x (1420+1665+1665)	1950x (1665+1665+1420)	1950x (1665+1665+1665)	1950x (1665+1665+1665)
			x790	x790	x790	x790	x790
Cabinet Color		Ivory White	Ivory White	Ivory White	Ivory White	Ivory White	
Ref. Piping	Gas	mm	φ50.8	φ50.8	φ50.8	φ50.8	φ50.8
		inch	2	2	2	2	2
	Liquid	mm	φ25.4	φ25.4	φ25.4	φ25.4	φ25.4
		inch	1	1	1	1	1
Connectable Indoor Units	Quantity	pcs	64	64	64	64	64
	Total Capacity	-	50%-150%	50%-150%	50%-150%	50%-150%	50%-150%
Piping Design	Height Difference Between ODU and IDU	m(above)	50(90**)	50(90**)	50(90**)	50(90**)	50(90**)
		m(below)	40(90**)	40(90**)	40(90**)	40(90**)	40(90**)
	Height Difference Between IDUs	m	30	30	30	30	30
	Max. Piping Length	m	1000	1000	1000	1000	1000
Operation Range*2	Cooling	DB	-5°C-52°C	-5°C-52°C	-5°C-52°C	-5°C-52°C	-5°C-52°C
	Heating	WB	-25°C-16.5°C	-25°C-16.5°C	-25°C-16.5°C	-25°C-16.5°C	-25°C-16.5°C

Hi-FLEXi S mavo+ Series



HP		86HP	88HP	90HP	92HP	
Model	Model	AVWT-824HKFSEA	AVWT-844HKFSEA	AVWT-866HKFSEA	AVWT-886HKFSEA	
	Modules	AVWT-190HKFSEA	AVWT-190HKFSEA	AVWT-190HKFSEA	AVWT-190HKFSEA	
		AVWT-190HKFSEA	AVWT-190HKFSEA	AVWT-212HKFSEA	AVWT-232HKFSEA	
		AVWT-212HKFSEA	AVWT-232HKFSEA	AVWT-232HKFSEA	AVWT-232HKFSEA	
		AVWT-232HKFSEA	AVWT-232HKFSEA	AVWT-232HKFSEA	AVWT-232HKFSEA	
Power Supply	AC 3 ϕ , 380-415V/50/60Hz					
Cooling	Capacity	kW	241.5	248.0	253.5	260.0
		kBtu/h	825.0	845.0	865.0	885.0
	Power Input	kW	68.48	70.54	72.98	75.03
	EER	kW/kW	3.53	3.52	3.47	3.47
Heating	Capacity	kW	270.0	276.0	282.0	288.0
		kBtu/h	920.0	940.0	960.0	985.0
	Power Input	kW	72.14	74.16	76.50	78.52
	COP	kW/kW	3.74	3.72	3.69	3.67
Ventilation	Air Flow Rate	m ³ /min	1126	1126	1155	1155
	Fan Quantity		8	8	8	8
	Static Pressure	Pa	110	110	110	110
Sound Pressure Level	Normal Mode	dB(A)	69	69	69	69
	Night Shift Mode	dB(A)	54	54	54	54
Compressor	Type	Scroll Compressor				
	Compressor Quantity	pcs	6	6	7	7
Refrigerant	Type	R410A				
	Pre-charged Quantity	kg	10.3+10.3+12.2+12.2	10.3+10.3+12.2+12.2	10.3+12.2+12.2+12.2	10.3+12.2+12.2+12.2
Weight	Net Weight	kg	316+316+363+365	316+316+365+365	316+363+365+365	316+365+365+365
	Gross Weight	kg	347+347+400+402	347+347+402+402	347+400+402+402	347+402+402+402
Dimensions	External(HxWxD)	mm	1730x (1350+1350+1350+1350)	1730x (1350+1350+1350+1350)	1730x (1350+1350+1350+1350)	1730x (1350+1350+1350+1350)
			x750	x750	x750	x750
	Packing(HxWxD)	mm	1950x (1420+1420+1420+1420)	1950x (1420+1420+1420+1420)	1950x (1420+1420+1420+1420)	1950x (1420+1420+1420+1420)
			x790	x790	x790	x790
Cabinet Color		Ivory White	Ivory White	Ivory White	Ivory White	
Ref. Piping	Gas	mm	ϕ 50.8	ϕ 50.8	ϕ 50.8	ϕ 50.8
		inch	2	2	2	2
	Liquid	mm	ϕ 25.4	ϕ 25.4	ϕ 25.4	ϕ 25.4
		inch	1	1	1	1
Connectable Indoor Units	Quantity	pcs	64	64	64	64
	Total Capacity	-	50%-150%	50%-150%	50%-150%	50%-150%
Piping Design	Height Difference Between ODU and IDU	m(above)	50(90**)	50(90**)	50(90**)	50(90**)
		m(below)	40(90**)	40(90**)	40(90**)	40(90**)
	Height Difference Between IDUs	m	30	30	30	30
	Max. Piping Length	m	1000	1000	1000	1000
Operation Range*2	Cooling	DB	-5 $^{\circ}$ C-52 $^{\circ}$ C	-5 $^{\circ}$ C-52 $^{\circ}$ C	-5 $^{\circ}$ C-52 $^{\circ}$ C	-5 $^{\circ}$ C-52 $^{\circ}$ C
	Heating	WB	-25 $^{\circ}$ C-16.5 $^{\circ}$ C	-25 $^{\circ}$ C-16.5 $^{\circ}$ C	-25 $^{\circ}$ C-16.5 $^{\circ}$ C	-25 $^{\circ}$ C-16.5 $^{\circ}$ C

Hi-FLEXi S mavo+ Series



HP		94HP	96HP	98HP	100HP	102HP	
Model	Model	AVWT-908HKFSEA	AVWT-928HKFSEA	AVWT-946HKFSEA	AVWT-968HKFSEA	AVWT-986HKFSEA	
	Modules	AVWT-212HKFSEA	AVWT-232HKFSEA	AVWT-232HKFSEA	AVWT-232HKFSEA	AVWT-232HKFSEA	
		AVWT-232HKFSEA	AVWT-232HKFSEA	AVWT-232HKFSEA	AVWT-232HKFSEA	AVWT-232HKFSEA	
		AVWT-232HKFSEA	AVWT-232HKFSEA	AVWT-232HKFSEA	AVWT-232HKFSEA	AVWT-250HKFSEA	
		AVWT-232HKFSEA	AVWT-232HKFSEA	AVWT-250HKFSEA	AVWT-272HKFSEA	AVWT-272HKFSEA	
Power Supply	AC 3 ϕ , 380-415V/50/60Hz						
Cooling	Capacity	kW	265.5	272.0	276.5	284.0	288.5
		kBtu/h	905.0	930.0	945.0	970.0	985.0
	Power Input	kW	77.48	79.53	80.48	83.75	84.70
	EER	kW/kW	3.43	3.42	3.44	3.39	3.41
Heating	Capacity	kW	294.0	300.0	305.0	315.0	320.0
		kBtu/h	1005.0	1025.0	1040.0	1075.0	1090.0
	Power Input	kW	80.85	82.87	84.13	87.72	88.98
	COP	kW/kW	3.64	3.62	3.63	3.59	3.60
Ventilation	Air Flow Rate	m ³ /min	1184	1184	1238	1238	1292
	Fan Quantity		8	8	8	8	8
	Static Pressure	Pa	110	110	110	110	110
Sound Pressure Level	Normal Mode	dB(A)	69	69	69	70	70
	Night Shift Mode	dB(A)	54	54	54	55	55
Compressor	Type	Scroll Compressor					
	Compressor Quantity	pcs	8	8	8	8	8
Refrigerant	Type	R410A					
	Pre-charged Quantity	kg	12.2+12.2+12.2+12.2	12.2+12.2+12.2+12.2	12.2+12.2+12.2+12.0	12.2+12.2+12.2+12.0	12.2+12.2+12.0+12.0
Weight	Net Weight	kg	363+365+365+365	365+365+365+365	365+365+365+391	365+365+365+392	365+365+391+392
	Gross Weight	kg	400+402+402+402	402+402+402+402	402+402+402+433	402+402+402+434	402+402+433+434
Dimensions	External(HxWxD)	mm	1730x (1350+1350+1350+1350)	1730x (1350+1350+1350+1350)	1730x (1350+1350+1350+1600)	1730x (1350+1350+1350+1600)	1730x (1350+1350+1600+1600)
			x750	x750	x750	x750	x750
	Packing(HxWxD)	mm	1950x (1420+1420+1420+1420)	1950x (1420+1420+1420+1420)	1950x (1420+1420+1420+1665)	1950x (1420+1420+1420+1665)	1950x (1420+1420+1665+1665)
			x790	x790	x790	x790	x790
Cabinet Color		Ivory White	Ivory White	Ivory White	Ivory White	Ivory White	
Ref. Piping	Gas	mm	ϕ 50.8	ϕ 50.8	ϕ 50.8	ϕ 50.8	ϕ 50.8
		inch	2	2	2	2	2
	Liquid	mm	ϕ 25.4	ϕ 25.4	ϕ 25.4	ϕ 25.4	ϕ 25.4
		inch	1	1	1	1	1
Connectable Indoor Units	Quantity	pcs	64	64	64	64	64
	Total Capacity	-	50%-150%	50%-150%	50%-150%	50%-150%	50%-150%
Piping Design	Height Difference Between ODU and IDU	m(above)	50(90**)	50(90**)	50(90**)	50(90**)	50(90**)
		m(below)	40(90**)	40(90**)	40(90**)	40(90**)	40(90**)
	Height Difference Between IDUs	m	30	30	30	30	30
	Max. Piping Length	m	1000	1000	1000	1000	1000
Operation Range*2	Cooling	DB	-5 $^{\circ}$ C-52 $^{\circ}$ C	-5 $^{\circ}$ C-52 $^{\circ}$ C	-5 $^{\circ}$ C-52 $^{\circ}$ C	-5 $^{\circ}$ C-52 $^{\circ}$ C	-5 $^{\circ}$ C-52 $^{\circ}$ C
	Heating	WB	-25 $^{\circ}$ C-16.5 $^{\circ}$ C	-25 $^{\circ}$ C-16.5 $^{\circ}$ C	-25 $^{\circ}$ C-16.5 $^{\circ}$ C	-25 $^{\circ}$ C-16.5 $^{\circ}$ C	-25 $^{\circ}$ C-16.5 $^{\circ}$ C

Hi-FLEXi S mavo+ Series



HP		104HP	106HP	108HP	110HP	112HP	
Model	Model	AVWT-1008HKFSEA	AVWT-1026HKFSEA	AVWT-1048HKFSEA	AVWT-1066HKFSEA	AVWT-1088HKFSEA	
	Modules	AVWT-232HKFSEA	AVWT-232HKFSEA	AVWT-232HKFSEA	AVWT-250HKFSEA	AVWT-272HKFSEA	
		AVWT-232HKFSEA	AVWT-250HKFSEA	AVWT-272HKFSEA	AVWT-272HKFSEA	AVWT-272HKFSEA	
		AVWT-272HKFSEA	AVWT-272HKFSEA	AVWT-272HKFSEA	AVWT-272HKFSEA	AVWT-272HKFSEA	
		AVWT-272HKFSEA	AVWT-272HKFSEA	AVWT-272HKFSEA	AVWT-272HKFSEA	AVWT-272HKFSEA	
Power Supply	AC 3Φ, 380-415V/50/60Hz						
Cooling	Capacity	kW	296.0	300.5	308.0	312.5	320.0
		kBtu/h	1010.0	1025.0	1050.0	1065.0	1090.0
	Power Input	kW	87.96	88.91	92.17	93.12	96.39
	EER	kW/kW	3.37	3.38	3.34	3.36	3.32
Heating	Capacity	kW	330.0	335.0	345.0	350.0	360.0
		kBtu/h	1125.0	1145.0	1175.0	1195.0	1230.0
	Power Input	kW	92.57	93.83	97.42	98.68	102.27
	COP	kW/kW	3.56	3.57	3.54	3.55	3.52
Ventilation	Air Flow Rate	m ³ /min	1292	1346	1346	1400	1400
	Fan Quantity		8	8	8	8	8
	Static Pressure	Pa	110	110	110	110	110
Sound Pressure Level	Normal Mode	dB(A)	70	70	70	70	70
	Night Shift Mode	dB(A)	55	55	55	55	55
Compressor	Type	Scroll Compressor					
	Compressor Quantity	pcs	8	8	8	8	8
Refrigerant	Type	R410A					
	Pre-charged Quantity	kg	12.2+12.2+12.0+12.0	12.2+12.0+12.0+12.0	12.2+12.0+12.0+12.0	12.0+12.0+12.0+12.0	12.0+12.0+12.0+12.0
Weight	Net Weight	kg	365+365+392+392	365+391+392+392	365+392+392+392	391+392+392+392	392+392+392+392
	Gross Weight	kg	402+402+434+434	402+433+434+434	402+434+434+434	433+434+434+434	434+434+434+434
Dimensions	External(HxWxD)	mm	(1350+1350+1600+1600)	(1350+1600+1600+1600)	(1350+1600+1600+1600)	(1600+1600+1600+1600)	(1600+1600+1600+1600)
			x750	x750	x750	x750	x750
	Packing(HxWxD)	mm	(1420+1420+1665+1665)	(1420+1665+1665+1665)	(1420+1665+1665+1665)	(1665+1665+1665+1665)	(1665+1665+1665+1665)
			x790	x790	x790	x790	x790
Cabinet Color		Ivory White	Ivory White	Ivory White	Ivory White	Ivory White	
Ref. Piping	Gas	mm	φ50.8	φ50.8	φ50.8	φ50.8	φ50.8
		inch	2	2	2	2	2
	Liquid	mm	φ25.4	φ25.4	φ25.4	φ25.4	φ25.4
		inch	1	1	1	1	1
Connectable Indoor Units	Quantity	pcs	64	64	64	64	64
	Total Capacity	-	50%-150%	50%-150%	50%-150%	50%-150%	50%-150%
Piping Design	Height Difference Between ODU and IDU	m(above)	50(90 ^{**})	50(90 ^{**})	50(90 ^{**})	50(90 ^{**})	50(90 ^{**})
		m(below)	40(90 ^{**})	40(90 ^{**})	40(90 ^{**})	40(90 ^{**})	40(90 ^{**})
	Height Difference Between IDUs	m	30	30	30	30	30
	Max. Piping Length	m	1000	1000	1000	1000	1000
Operation Range ^{**}	Cooling	DB	-5°C-52°C	-5°C-52°C	-5°C-52°C	-5°C-52°C	-5°C-52°C
	Heating	WB	-25°C-16.5°C	-25°C-16.5°C	-25°C-16.5°C	-25°C-16.5°C	-25°C-16.5°C

NOTES:

1. Rated capacity is tested in the following conditions:

Pipe length: 7.5m, Pipe height difference: 0m; Cooling operation: indoor air inlet temperature 27°CDB 19°CWB, outdoor ambient temperature 35°CDB;
Heating operation: indoor air inlet temperature 20°CDB, outdoor ambient temperature 7°CDB 6°CWB.

2. The above noise values are measured in the anechoic chamber without reflected echo. Measurement point: 1 meter from the service cover surface and 1.5 meters from floor level.

*1: For height difference between ODU & IDU more than 50(40)m, please contact with our professional engineer.

*2: When the operation temperature is under 48°C DB ~ 52°C DB or -25°C WB ~ -20°C WB, the system may be in intermittent operation. Please contact with our professional engineer.

Hi-FLEXi X Series



Hi-FLEXi X Series



Piping Length

With extra long pipe, the height difference between the indoor unit and outdoor unit is up to 90 meters*, which makes installation more flexible.

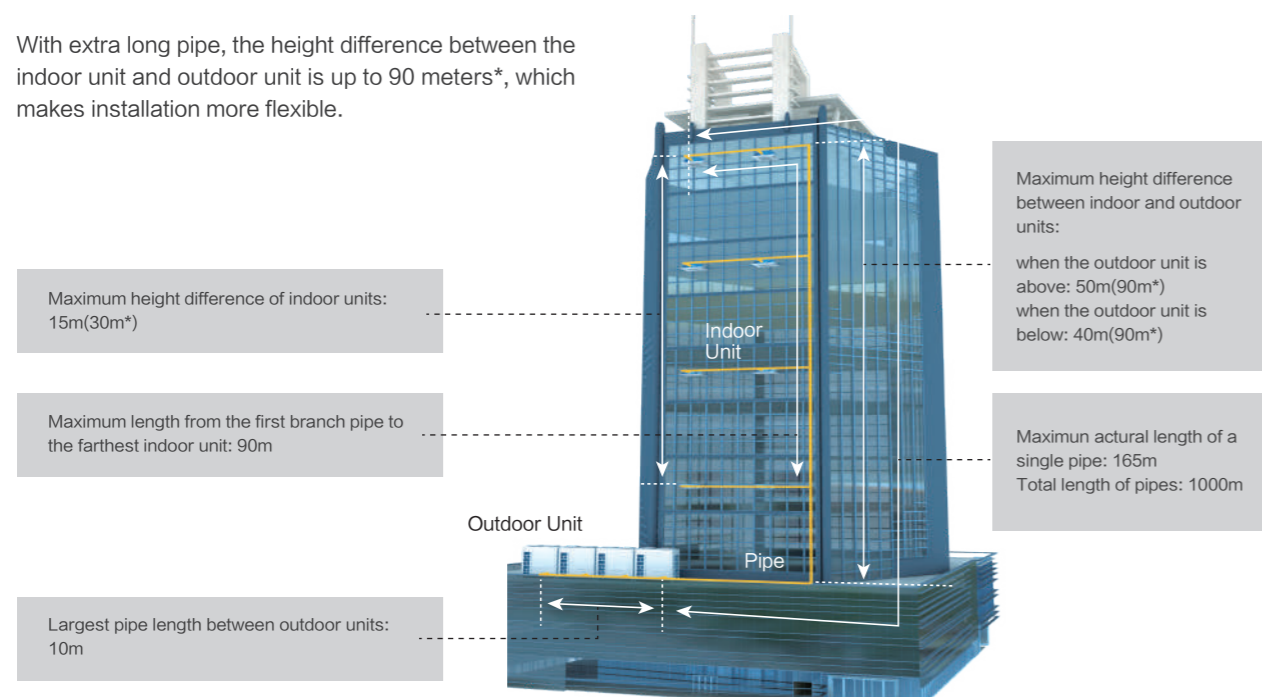

*Note: For detailed information, please contact Hisense's technical staff.

HP		8HP	10HP	12HP	14HP	16HP	
Model	Model	AVWT-76UESRX	AVWT-96UESRX	AVWT-114UESX	AVWT-136UESX	AVWT-154UESX	
Model	Modules	—	—	—	—	—	
	Power Supply	AC 3 φ, 380-415V/50Hz					
Cooling	Capacity	kW	22.4	28.0	33.5	40.0	45.0
		kBtu/h	76.5	95.6	114.3	136.5	153.5
	Power Input	kW	5.25	7.31	8.57	11.05	13.16
	EER	kW/kW	4.27	3.83	3.91	3.62	3.42
Heating	Capacity	kW	25.0	31.5	37.5	45.0	50.0
		kBtu/h	85.3	107.5	128.0	153.5	170.6
	Power Input	kW	5.62	7.61	8.89	11.08	12.47
	COP	kW/kW	4.45	4.14	4.22	4.06	4.01
Ventilation	Air Flow Rate	m ³ /min	155	170	175	190	190
	Fan Quantity		1	1	1	1	1
	Static Pressure	Pa	85	85	85	85	85
Sound	Sound Pressure Level	dB(A)	62/54	64/55	64/56	65/57	66/58
	Type		Scroll				
Compressor	Compressor Quantity	pcs	1	1	1	1	1
	Type		R410A				
Refrigerant	Pre-charged Quantity	kg	6.5	6.5	9.0	9.0	10.5
	Net Weight	kg	197	197	224	227	247
Weight	Gross Weight	kg	223	223	248	250	272
	External(H × W × D)	mm	1720 × 950 × 750	1720 × 950 × 750	1720 × 1210 × 750	1720 × 1210 × 750	1720 × 1210 × 750
Dimensions	Packing(H × W × D)	mm	1882 × 1018 × 828	1882 × 1018 × 828	1882 × 1278 × 828	1882 × 1278 × 828	1882 × 1278 × 828
	Cabinet Color		Ivory White				
Ref. Piping	Gas	mm	φ19.05	φ22.2	φ25.4	φ25.4	φ28.6
		inch	3/4	7/8	1	1	1-1/8
Connectable Indoor Units	Liquid	mm	φ9.53	φ9.53	φ12.7	φ12.7	φ12.7
		inch	3/8	3/8	1/2	1/2	1/2
Piping Design	Quantity	pcs	13	16	19	23	26
	Total Capacity	—	50-130%	50-130%	50-130%	50-130%	50-130%
Operation Range	Height Difference Between ODU and IDU	m(above)	50 (90**)	50 (90**)	50 (90**)	50 (90**)	50 (90**)
		m(below)	40 (90**)	40 (90**)	40 (90**)	40 (90**)	40 (90**)
	Height Difference Between IDUs	m	15 (30**)	15 (30**)	15 (30**)	15 (30**)	15 (30**)
	Max. Piping Length	m	165	165	165	165	165
Cooling	DB		-5°C-52°C	-5°C-52°C	-5°C-52°C	-5°C-52°C	-5°C-52°C
	Heating	WB	-20°C-15°C	-20°C-15°C	-20°C-15°C	-20°C-15°C	-20°C-15°C

Hi-FLEXi X Series



Hi-FLEXi X Series



HP		18HP	20HP	22HP	24HP	26HP	
Model	Model	AVWT-172UESZX	AVWT-190UESZX	AVWT-210UESZX	AVWT-229UESZX	AVWT-250UESZX	
	Modules	AVWT-76UESRX AVWT-96UESRX	AVWT-76UESRX AVWT-114UESX	AVWT-96UESRX AVWT-114UESX	AVWT-114UESX AVWT-114UESX	AVWT-114UESX AVWT-136UESX	
Power Supply		AC 3Φ, 380-415V/50Hz					
Cooling	Capacity	kW	50.4	56.0	61.5	67.0	73.5
		kBtu/h	172.0	191.1	209.8	228.6	250.8
	Power Input	kW	12.56	13.82	15.88	17.14	19.62
	EER	kW/kW	4.01	4.05	3.87	3.91	3.75
Heating	Capacity	kW	56.5	62.5	69.0	75.0	82.5
		kBtu/h	192.8	213.3	235.5	256.0	281.5
	Power Input	kW	13.23	14.51	16.50	17.78	19.97
	COP	kW/kW	4.27	4.31	4.18	4.22	4.13
Ventilation	Air Flow Rate	m ³ /min	155+170	155+175	170+175	175+175	175+190
	Fan Quantity		1+1	1+1	1+1	1+1	1+1
	Static Pressure	Pa	85	85	85	85	85
Sound	Sound Pressure Level	dB(A)	66/57	68/60	68/60	68/60	68/60
	Type		Scroll				
Compressor	Compressor Quantity	pcs	1+1	1+1	1+1	1+1	1+1
	Type		R410A				
Refrigerant	Pre-charged Quantity	kg	13.0	15.5	15.5	18.0	18.0
	Net Weight	kg	197+197	197+224	197+224	224+224	224+227
Weight	Gross Weight	kg	223+223	223+248	223+248	248+248	248+250
	External(H × W × D)	mm	1720 × (950+950) × 750	1720 × (950+1210) × 750	1720 × (950+1210) × 750	1720 × (1210+1210) × 750	1720 × (1210+1210) × 750
Dimensions	Packing(H × W × D)	mm	—	—	—	—	—
	Cabinet Color		Ivory White	Ivory White	Ivory White	Ivory White	Ivory White
Ref. Piping	Gas	mm	φ28.6	φ28.6	φ28.6	φ28.6	φ31.75
		inch	1-1/8	1-1/8	1-1/8	1-1/8	1-1/4
	Liquid	mm	φ15.88	φ15.88	φ15.88	φ15.88	φ19.05
		inch	5/8	5/8	5/8	5/8	3/4
Connectable Indoor Units	Quantity	pcs	26	33	36	40	43
	Total Capacity	—	50-130%	50-130%	50-130%	50-130%	50-130%
Piping Design	Height Difference Between ODU and IDU	m(above)	50 (90**)	50 (90**)	50 (90**)	50 (90**)	50 (90**)
		m(below)	40 (90**)	40 (90**)	40 (90**)	40 (90**)	40 (90**)
	Height Difference Between IDUs	m	15 (30**)	15 (30**)	15 (30**)	15 (30**)	15 (30**)
	Max. Piping Length	m	165	165	165	165	165
Operation Range	Cooling	DB	-5°C-52°C	-5°C-52°C	-5°C-52°C	-5°C-52°C	-5°C-52°C
	Heating	WB	-20°C-15°C	-20°C-15°C	-20°C-15°C	-20°C-15°C	-20°C-15°C

HP		28HP	30HP	32HP	34HP	36HP	
Model	Model	AVWT-268UESZX	AVWT-290UESZX	AVWT-307UESZX	AVWT-324UESZX	AVWT-343UESZX	
	Modules	AVWT-114UESX AVWT-154UESX	AVWT-136UESX AVWT-154UESX	AVWT-154UESX AVWT-154UESX	AVWT-96UESRX AVWT-114UESX AVWT-114UESX	AVWT-114UESX AVWT-114UESX AVWT-114UESX	
Power Supply		AC 3Φ, 380-415V/50Hz					
Cooling	Capacity	kW	78.5	85.0	90.0	96.0	100.5
		kBtu/h	267.8	290.0	307.1	327.6	342.9
	Power Input	kW	21.73	24.21	26.32	24.45	25.71
	EER	kW/kW	3.61	3.51	3.42	3.93	3.91
Heating	Capacity	kW	87.5	95.0	100.0	106.5	112.5
		kBtu/h	298.6	324.1	341.2	363.5	384.0
	Power Input	kW	21.36	23.55	24.94	25.39	26.67
	COP	kW/kW	4.10	4.03	4.01	4.19	4.22
Ventilation	Air Flow Rate	m ³ /min	175+190	190+190	190+190	170+175+175	175+175+175
	Fan Quantity		1+1	1+1	1+1	1+1+1	1+1+1
	Static Pressure	Pa	85	85	85	85	85
Sound	Sound Pressure Level	dB(A)	69/61	69/61	69/62	70/63	70/63
	Type		Scroll				
Compressor	Compressor Quantity	pcs	1+1	1+1	1+1	1+1+1	1+1+1
	Type		R410A				
Refrigerant	Pre-charged Quantity	kg	19.5	19.5	21.0	24.5	27.0
	Net Weight	kg	224+247	227+247	247+247	197+224+224	224+224+224
Weight	Gross Weight	kg	248+272	250+272	272+272	223+248+248	248+248+248
	External(H × W × D)	mm	1720 × (1210+1210) × 750	1720 × (1210+1210) × 750	1720 × (1210+1210) × 750	1720 × (950+1210+1210) × 750	1720 × (1210+1210+1210) × 750
Dimensions	Packing(H × W × D)	mm	—	—	—	—	—
	Cabinet Color		Ivory White	Ivory White	Ivory White	Ivory White	Ivory White
Ref. Piping	Gas	mm	φ31.75	φ31.75	φ31.75	φ31.75	φ38.1
		inch	1-1/4	1-1/4	1-1/4	1-1/4	1-1/2
	Liquid	mm	φ19.05	φ19.05	φ19.05	φ19.05	φ19.05
		inch	3/4	3/4	3/4	3/4	3/4
Connectable Indoor Units	Quantity	pcs	47	50	53	56	59
	Total Capacity	—	50-130%	50-130%	50-130%	50-130%	50-130%
Piping Design	Height Difference Between ODU and IDU	m(above)	50 (90**)	50 (90**)	50 (90**)	50 (90**)	50 (90**)
		m(below)	40 (90**)	40 (90**)	40 (90**)	40 (90**)	40 (90**)
	Height Difference Between IDUs	m	15 (30**)	15 (30**)	15 (30**)	15 (30**)	15 (30**)
	Max. Piping Length	m	165	165	165	165	165
Operation Range	Cooling	DB	-5°C-52°C	-5°C-52°C	-5°C-52°C	-5°C-52°C	-5°C-52°C
	Heating	WB	-20°C-15°C	-20°C-15°C	-20°C-15°C	-20°C-15°C	-20°C-15°C

Hi-FLEXi X Series



Hi-FLEXi X Series



HP		38HP	40HP	42HP	44HP	46HP	
Model	Model	AVWT-365UESZX	AVWT-386UESZX	AVWT-404UESZX	AVWT-420UESZX	AVWT-444UESZX	
	Modules	AVWT-114UESX	AVWT-114UESX	AVWT-114UESX	AVWT-114UESX	AVWT-136UESX	
		AVWT-114UESX	AVWT-114UESX	AVWT-136UESX	AVWT-154UESX	AVWT-154UESX	
Power Supply		AC 3Φ, 380-415V/50Hz					
Cooling	Capacity	kW	107.0	113.0	118.5	123.5	130.0
		kBtu/h	365.1	385.6	404.3	421.1	443.6
	Power Input	kW	28.19	30.30	32.78	34.89	37.37
	EER	kW/kW	3.80	3.73	3.62	3.54	3.48
Heating	Capacity	kW	120.0	125.0	132.5	137.5	145.0
		kBtu/h	409.5	426.6	452.1	469.2	494.7
	Power Input	kW	28.86	30.25	32.44	33.83	36.02
	COP	kW/kW	4.16	4.13	4.08	4.06	4.03
Ventilation	Air Flow Rate	m³/min	175+175+190	175+175+190	175+190+190	175+190+190	190+190+190
	Fan Quantity		1+1+1	1+1+1	1+1+1	1+1+1	1+1+1
	Static Pressure	Pa	85	85	85	85	85
Sound	Sound Pressure Level	dB(A)	71/64	71/64	71/64	72/65	72/65
	Type		Scroll				
Compressor	Compressor Quantity	pcs	1+1+1	1+1+1	1+1+1	1+1+1	1+1+1
	Type		R410A				
Refrigerant	Pre-charged Quantity	kg	27.0	28.5	28.5	30.0	30.0
	Net Weight	kg	224+224+227	224+224+247	224+227+247	224+247+247	227+247+247
Weight	Gross Weight	kg	248+248+250	248+248+272	248+250+272	248+272+272	250+272+272
	External(H×W×D)	mm	1720× (1210+1210+1210) ×750	1720× (1210+1210+1210) ×750	1720× (1210+1210+1210) ×750	1720× (1210+1210+1210) ×750	1720× (1210+1210+1210) ×750
Dimensions	Packing(H×W×D)	mm	—	—	—	—	—
	Cabinet Color		Ivory White				
Ref. Piping	Gas	mm	φ38.1	φ38.1	φ38.1	φ38.1	φ38.1
		inch	1-1/2	1-1/2	1-1/2	1-1/2	1-1/2
	Liquid	mm	φ19.05	φ19.05	φ19.05	φ19.05	φ19.05
		inch	3/4	3/4	3/4	3/4	3/4
Connectable Indoor Units	Quantity	pcs	64	64	64	64	64
	Total Capacity	—	50-130%	50-130%	50-130%	50-130%	50-130%
Piping Design	Height Difference Between ODU and IDU	m(above)	50 (90**)	50 (90**)	50 (90**)	50 (90**)	50 (90**)
		m(below)	40 (90**)	40 (90**)	40 (90**)	40 (90**)	40 (90**)
	Height Difference Between IDUs	m	15 (30**)	15 (30**)	15 (30**)	15 (30**)	15 (30**)
	Max. Piping Length	m	165	165	165	165	165
Operation Range	Cooling	DB	-5°C-52°C	-5°C-52°C	-5°C-52°C	-5°C-52°C	-5°C-52°C
	Heating	WB	-20°C-15°C	-20°C-15°C	-20°C-15°C	-20°C-15°C	-20°C-15°C

HP		48HP	50HP	52HP	54HP	56HP	
Model	Model	AVWT-460UESZX	AVWT-480UESZX	AVWT-500UESZX	AVWT-520UESZX	AVWT-540UESZX	
	Modules	AVWT-154UESX	AVWT-114UESX	AVWT-114UESX	AVWT-114UESX	AVWT-114UESX	
		AVWT-154UESX	AVWT-114UESX	AVWT-136UESX	AVWT-136UESX	AVWT-154UESX	
Power Supply		AC 3Φ, 380-415V/50Hz					
Cooling	Capacity	kW	135.0	140.4	146.0	151.5	157.0
		kBtu/h	460.6	479.0	498.2	516.9	535.7
	Power Input	kW	39.48	36.76	39.24	41.35	43.46
	EER	kW/kW	3.42	3.82	3.72	3.66	3.61
Heating	Capacity	kW	150.0	156.5	163.0	169.0	175.0
		kBtu/h	511.8	534.0	556.2	576.6	597.1
	Power Input	kW	37.41	37.75	39.94	41.33	42.72
	COP	kW/kW	4.01	4.15	4.08	4.09	4.10
Ventilation	Air Flow Rate	m³/min	190+190+190	175+175+175+190	175+175+190+190	175+175+190+190	175+175+190+190
	Fan Quantity		1+1+1	1+1+1+1	1+1+1+1	1+1+1+1	1+1+1+1
	Static Pressure	Pa	85	85	85	85	85
Sound	Sound Pressure Level	dB(A)	72/65	73/66	73/66	73/66	73/66
	Type		Scroll				
Compressor	Compressor Quantity	pcs	1+1+1	1+1+1+1	1+1+1+1	1+1+1+1	1+1+1+1
	Type		R410A				
Refrigerant	Pre-charged Quantity	kg	31.5	36.0	36.0	37.5	39.0
	Net Weight	kg	247+247+247	224+224+224+227	224+224+227+227	224+224+227+247	224+224+247+247
Weight	Gross Weight	kg	272+272+272	248+248+248+250	248+248+250+250	248+248+250+272	248+248+272+272
	External(H×W×D)	mm	1720× (1210+1210+1210) ×750	1720× (1210+1210+1210+1210) ×750	1720× (1210+1210+1210+1210) ×750	1720× (1210+1210+1210+1210) ×750	1720× (1210+1210+1210+1210) ×750
Dimensions	Packing(H×W×D)	mm	—	—	—	—	—
	Cabinet Color		Ivory White				
Ref. Piping	Gas	mm	φ38.1	φ41.3	φ41.3	φ41.3	φ41.3
		inch	1-1/2	1-5/8	1-5/8	1-5/8	1-5/8
	Liquid	mm	φ19.05	φ22.2	φ22.2	φ22.2	φ22.2
		inch	3/4	7/8	7/8	7/8	7/8
Connectable Indoor Units	Quantity	pcs	64	64	64	64	64
	Total Capacity	—	50-130%	50-130%	50-130%	50-130%	50-130%
Piping Design	Height Difference Between ODU and IDU	m(above)	50 (90**)	50 (90**)	50 (90**)	50 (90**)	50 (90**)
		m(below)	40 (90**)	40 (90**)	40 (90**)	40 (90**)	40 (90**)
	Height Difference Between IDUs	m	15 (30**)	15 (30**)	15 (30**)	15 (30**)	15 (30**)
	Max. Piping Length	m	165	165	165	165	165
Operation Range	Cooling	DB	-5°C-52°C	-5°C-52°C	-5°C-52°C	-5°C-52°C	-5°C-52°C
	Heating	WB	-20°C-15°C	-20°C-15°C	-20°C-15°C	-20°C-15°C	-20°C-15°C

Hi-FLEXi X Series



HP		58HP	60HP	62HP	64HP	
Model	Model	AVWT-560UESZX	AVWT-580UESZX	AVWT-600UESZX	AVWT-620UESZX	
	Modules	AVWT-114UESSX	AVWT-114UESSX	AVWT-136UESSX	AVWT-154UESSX	
		AVWT-136UESSX	AVWT-154UESSX	AVWT-154UESSX	AVWT-154UESSX	
		AVWT-154UESSX	AVWT-154UESSX	AVWT-154UESSX	AVWT-154UESSX	
Power Supply		AC 3 ϕ , 380-415V/50Hz				
Cooling	Capacity	kW	163.5	168.5	175.0	180.0
		kBtu/h	557.9	574.9	597.1	614.2
	Power Input	kW	45.94	48.05	50.53	52.64
	EER	kW/kW	3.56	3.51	3.46	3.42
Heating	Capacity	kW	182.5	187.5	195.0	200.0
		kBtu/h	622.7	639.8	665.3	682.4
	Power Input	kW	44.91	46.30	48.49	49.88
	COP	kW/kW	4.06	4.05	4.02	4.01
Ventilation	Air Flow Rate	m ³ /min	175+190+190+190	175+190+190+190	190+190+190+190	190+190+190+190
	Fan Quantity		1+1+1+1	1+1+1+1	1+1+1+1	1+1+1+1
	Static Pressure	Pa	85	85	85	85
Sound	Sound Pressure Level	dB(A)	74/67	74/67	74/67	74/67
Compressor	Type	Scroll				
	Compressor Quantity	pcs	1+1+1+1	1+1+1+1	1+1+1+1	1+1+1+1
Refrigerant	Type	R410A				
	Pre-charged Quantity	kg	39.0	40.5	40.5	42.0
Weight	Net Weight	kg	224+227+247+247	224+247+247+247	227+247+247+247	247+247+247+247
	Gross Weight	kg	248+250+272+272	248+272+272+272	250+272+272+272	272+272+272+272
Dimensions	External(H x W x D)	mm	1720 x (1210+1210+1210+1210) x 750	1720 x (1210+1210+1210+1210) x 750	1720 x (1210+1210+1210+1210) x 750	1720 x (1210+1210+1210+1210) x 750
	Packing(H x W x D)	mm	—	—	—	—
Cabinet Color		Ivory White				
Ref. Piping	Gas	mm	ϕ 44.5	ϕ 44.5	ϕ 44.5	ϕ 44.5
		inch	1-3/4	1-3/4	1-3/4	1-3/4
	Liquid	mm	ϕ 22.2	ϕ 22.2	ϕ 22.2	ϕ 22.2
		inch	7/8	7/8	7/8	7/8
Connectable Indoor Units	Quantity	pcs	64	64	64	64
	Total Capacity	—	50-130%	50-130%	50-130%	50-130%
Piping Design	Height Difference Between ODU and IDU	m(above)	50 (90 ^{**})	50 (90 ^{**})	50 (90 ^{**})	50 (90 ^{**})
		m(below)	40 (90 ^{**})	40 (90 ^{**})	40 (90 ^{**})	40 (90 ^{**})
	Height Difference Between IDUs	m	15 (30 ^{**})	15 (30 ^{**})	15 (30 ^{**})	15 (30 ^{**})
	Max. Piping Length	m	165	165	165	165
Operation Range	Cooling	DB	-5 $^{\circ}$ C-52 $^{\circ}$ C	-5 $^{\circ}$ C-52 $^{\circ}$ C	-5 $^{\circ}$ C-52 $^{\circ}$ C	-5 $^{\circ}$ C-52 $^{\circ}$ C
	Heating	WB	-20 $^{\circ}$ C-15 $^{\circ}$ C	-20 $^{\circ}$ C-15 $^{\circ}$ C	-20 $^{\circ}$ C-15 $^{\circ}$ C	-20 $^{\circ}$ C-15 $^{\circ}$ C

NOTES:

- Rated cooling capacity is tested in the following conditions:
Cooling conditions: indoor air inlet temperature: 27 $^{\circ}$ C DB 19 $^{\circ}$ C WB, outdoor air inlet temperature: 35 $^{\circ}$ C DB, pipe length: 7.5m, pipe height difference: 0m.
- The above noise values are measured in the anechoic chamber without reflected echo, therefore the impact of the reflected echo must be included at the scene.

The final appearance of outdoor units is subject to the actual products.

- For 4 modular combination please contact manufacture for special design.
- When the cooling operation temperature is over 52 $^{\circ}$ C, please contact our professional engineer.
- For detailed information, please contact with Hisense's technical staff.

*1:

Hi-Smart H Series



Compact Size and Light Weight

Mini VRF H series outdoor units are compact in size for more convenient and flexible space design and installation. They can be installed in corners of balconies and yards or even on rooftops when necessary. With smaller and slimmer body frames, a lot of unnecessary weight is taken off, which makes installation or positioning simpler.



Aviation Level Design of Grilling

Hisense H series creates a high-quality quiet environment. The design of the grilling follows the design concept of the aircraft engine design, which conforms to the aerodynamics principle. The noise has been greatly reduced. The grilling also increases safety as being a preventative for child figure being injured by the fan blade.



New Designed Air Channel

An additional air duct-like channel surrounding the fan is designed to further discharge the air and avoid discharge air from being absorbed again. Air is tested to discharge up to 24% further compared with the conventional one. Besides, 30Pa external static pressure is available for units capacity ranged from 8HP to 12HP.

24%
Further Air Discharge

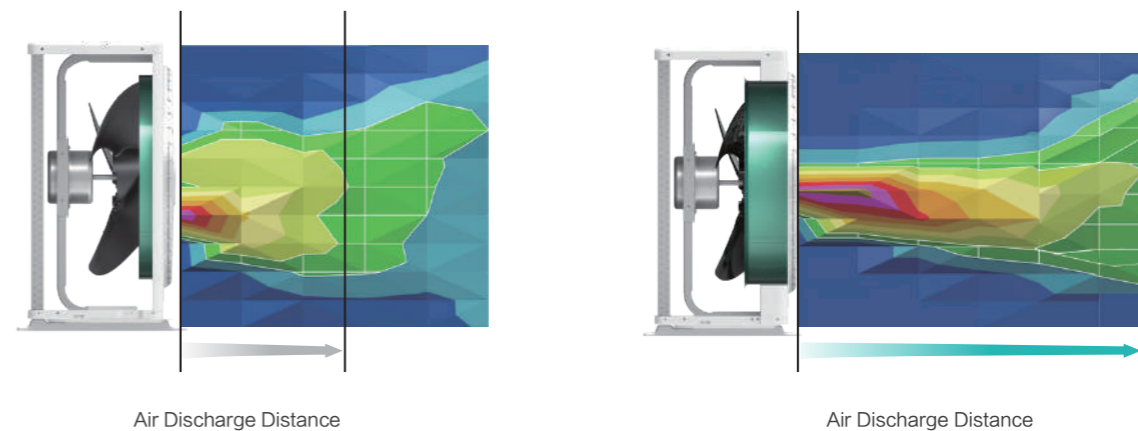

1.5-2m/s 2-2.5m/s 2.5-3m/s

Flexible Piping Connection

Installation restrictions on site does not stop Hisense mini VRF there with flexible piping directions which includes front, bottom, right, rear connections.



New Refrigerant Pipe Connection with Flare-nut Branch Pipe

Hisense VRF has newly developed the Flare-nut Branch Pipes, breaking through the common way of connecting refrigerant copper pipes by replacing welding processes with simple and safe flare nuts connections.

- Convenient and simple installation
- Saving installation time and cost
- Enhanced safety with no fire-involving process
- Preventing leakages due to poor welding
- No hot work permit application is required

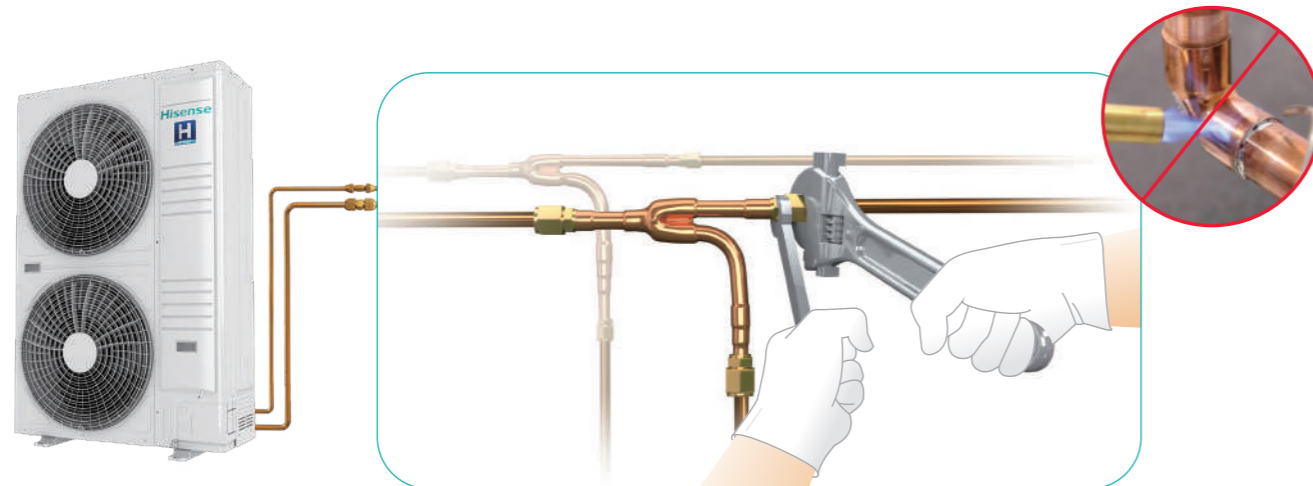
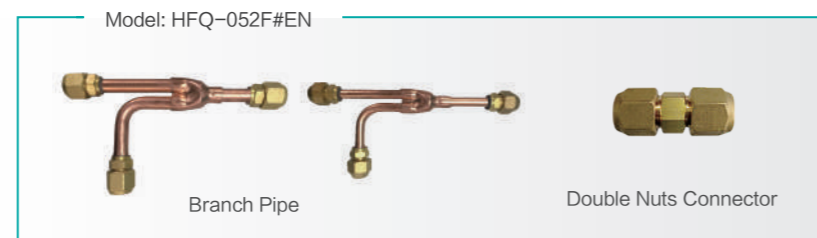

Excellent Piping Length

Increased piping length allows for flexible design and installation. Hisense inverter technology and two-level cooling technology allows longer piping length and outstanding height differences. The air-conditioning system can be implemented more flexibly.

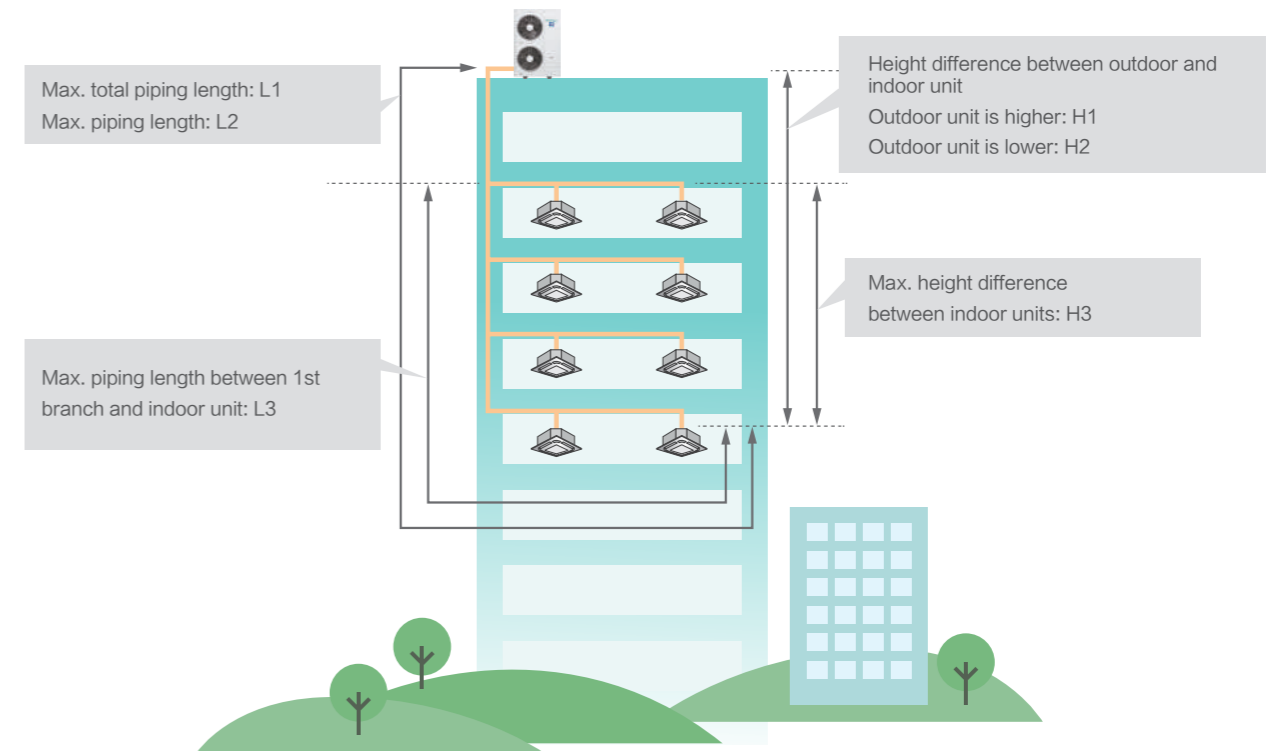

Power supply	AC 1φ, 220-240V/50/60Hz			AC 1φ, 220-240V/50/60Hz	AC 3φ, 380-415V/50/60Hz	AC 3φ, 380-415V/50/60Hz
	3HP	4HP	5HP	4/5/6HP	8HP	10/12HP
HP						
Picture						
Max. total piping length L1	30	40	60	120	150	250
Max. piping length L2	25	25	50	75	100	100
Max. length between the first branch pipe and the farthest indoor unit L3	10	15	20	30	30	40
Height difference between ODU and IDU	Outdoor unit is higher H1	20	20	20	30	50
	Outdoor unit is lower H2	20	20	20	30	40
Height difference between IDUs H3	3.5	3.5	3.5	10	15	15

Hi-Smart H Series



HP		3HP	4HP	5HP	
Model		AVW-28HJFH	AVW-34HJFH	AVW-43HJFH	
Power Supply		AC 1ϕ, 220V~240V/50/60Hz			
Cooling	Capacity	kW	8.0	10.0	12.5
		kBtu/h	27.3	34.1	42.7
	Power Input	kW	1.93	2.43	2.98
	EER	kW/kW	4.15	4.27	4.19
Heating	Capacity	kW	9.5	11.2	14.0
		kBtu/h	32.4	38.2	47.8
	Power Input	kW	2.37	3.01	4.15
	COP	kW/kW	4.01	3.72	3.37
Ventilation	Air Flow Rate	m ³ /min	46.5	69.0	78.0
Sound	Sound Pressure Level (Cooling/Heating)	dB(A)	50/52	53/55	54/57
Compressor	Type	Twin Rotary			
	Type	-			
Refrigerant	Type	R410A			
	Pre-charged Quantity	kg	2.5	2.8	2.8
Weight	Net Weight	kg	65	73	78
	Gross Weight	kg	72	81	86
Dimensions	External(HxWxD)	mm	800x950x370	800x950x370	800x950x370
	Packing(HxWxD)	mm	951x1070x515	951x1070x515	951x1070x515
Cabinet Color		Ivory White			
Ref. Piping	Gas	mm	ϕ15.88	ϕ15.88	ϕ15.88
		inch	5/8	5/8	5/8
	Liquid	mm	ϕ9.53	ϕ9.53	ϕ9.53
		inch	3/8	3/8	3/8
Connectable Indoor Units	Quantity	pcs	5	6	8
	Total Capacity	-	50%~125%	50%~125%	50%~125%
Piping Design	Height Difference Between ODU and IDU	m	20	20	20
		m	20	20	20
	Height Difference Between IDUs	m	3.5	3.5	3.5
		m	25	25	50
Operation Range	Cooling	DB	-5°C~46°C	-5°C~46°C	-5°C~46°C
	Heating	WB	-15°C~15.5°C	-15°C~15.5°C	-15°C~15.5°C

Hi-Smart H Series



HP		4HP	5HP	6HP	
Model		AVW-38HJFH	AVW-48HJFH	AVW-54HJFH	
Power Supply		AC 1ϕ, 220V~240V/50/60Hz			
Cooling	Capacity	kW	11.2	14.0	15.5
		kBtu/h	38.2	47.8	52.9
	Power Input	kW	2.60	3.46	4.21
	EER	kW/kW	4.31	4.05	3.68
Heating	Capacity	kW	12.5	16.0	18.0
		kBtu/h	42.7	54.6	61.4
	Power Input	kW	2.78	3.71	4.47
	COP	kW/kW	4.50	4.31	4.03
Ventilation	Air Flow Rate	m ³ /min	90.0	90.0	100.0
Sound	Sound Pressure Level (Cooling/Heating)	dB(A)	50/52	52/54	53/55
Compressor	Type	Twin Rotary			
	Type	-			
Refrigerant	Type	R410A			
	Pre-charged Quantity	kg	3.8	3.8	4.1
Weight	Net Weight	kg	93	95	97
	Gross Weight	kg	111	111	111
Dimensions	External(HxWxD)	mm	1380x950x370	1380x950x370	1380x950x370
	Packing(HxWxD)	mm	1531x1070x515	1531x1070x515	1531x1070x515
Cabinet Color		Ivory White			
Ref. Piping	Gas	mm	ϕ15.88	ϕ15.88	ϕ15.88
		inch	5/8	5/8	5/8
	Liquid	mm	ϕ9.53	ϕ9.53	ϕ9.53
		inch	3/8	3/8	3/8
Connectable Indoor Units	Quantity	pcs	9	11	11
	Total Capacity	-	50%~150%	50%~150%	50%~150%
Piping Design	Height Difference Between ODU and IDU	m	30	30	30
		m	30	30	30
	Height Difference Between IDUs	m	10	10	10
		m	75	75	75
Operation Range	Cooling	DB	-5°C~46°C	-5°C~46°C	-5°C~46°C
	Heating	WB	-20°C~15.5°C	-20°C~15.5°C	-20°C~15.5°C

Hi-Smart H Series



HP		8HP	10HP	12HP	
Model		AVW-76HKFH1	AVW-96HKFH1	AVW-114HKFH1	
Power Supply		AC 3 ϕ , 380V~415V/50/60Hz			
Cooling	Capacity	22.4	28.0	33.5	
	kBtu/h	76.5	95.6	114.3	
	Power Input	6.37	7.75	10.30	
	SEER	6.62	6.85	6.29	
Heating	EER	3.52	3.61	3.25	
	Capacity	25.0	31.5	37.5	
	kBtu/h	85.3	107.5	128	
	Power Input	5.84	7.00	10.00	
Heating	SCOP	4.10	4.21	3.98	
	COP	4.28	4.50	3.75	
	Air Flow Rate	127.0	150.0	163.0	
Ventilation	m ³ /min				
Sound	Sound Pressure Level (Cooling/Heating)	57/58	58/59	59/60	
	dB(A)				
Compressor	Type	Twin Rotary			
	Type	R410A			
Refrigerant	Type	R410A			
	Pre-charged Quantity	5.63	5.50	6.50	
Weight	Net Weight	124	145	158	
	Gross Weight	139	161	175	
Dimensions	External (HxWxD)	1380x950x370	1650x1100x390	1650x1100x390	
	Packing(HxWxD)	1531x1070x515	1806x1185x530	1806x1185x530	
Cabinet Color		Ivory White			
Ref. Piping	Gas	mm	ϕ 19.05	ϕ 22.2	ϕ 25.4
		inch	3/4	7/8	1
	Liquid	mm	ϕ 9.53	ϕ 12.7	ϕ 12.7
		inch	3/8	1/2	1/2
Connectable Indoor Units	Quantity	15	17	19	
	Total Capacity	50%~150%	50%~150%	50%~150%	
Piping Design	Height Difference Between ODU and IDU	50	50	50	
	m	40	40	40	
	Height Difference Between IDUs	15	15	15	
	m				
	Max. Piping Length	100	100	100	
Total Piping Length	150	250	250		
Operation Range	Cooling	DB	-5 $^{\circ}$ C~50 $^{\circ}$ C	-5 $^{\circ}$ C~50 $^{\circ}$ C	-5 $^{\circ}$ C~50 $^{\circ}$ C
	Heating	WB	-20 $^{\circ}$ C~15.5 $^{\circ}$ C	-20 $^{\circ}$ C~15.5 $^{\circ}$ C	-20 $^{\circ}$ C~15.5 $^{\circ}$ C

NOTES:

1. Rated cooling capacity and rated heating capacity are tested in the following conditions:

Cooling conditions: indoor air inlet temperature: 27 $^{\circ}$ C DB 19 $^{\circ}$ C WB, outdoor air inlet temperature: 35 $^{\circ}$ C DB, pipe length: 7.5m, pipe height difference: 0m.

Heating conditions: indoor air inlet temperature: 20 $^{\circ}$ C DB, outdoor air inlet temperature: 7 $^{\circ}$ C DB 6 $^{\circ}$ C WB, pipe length: 7.5m, pipe height difference: 0m.

2. The sound pressure level is based on following conditions:

1.5m beneath the unit.

The above data was measured in an anechoic chamber so that reflected sound should be taken into consideration in the field.

Hi-FLEXi W Series



Available for two-pipe Systems and three-pipe Systems

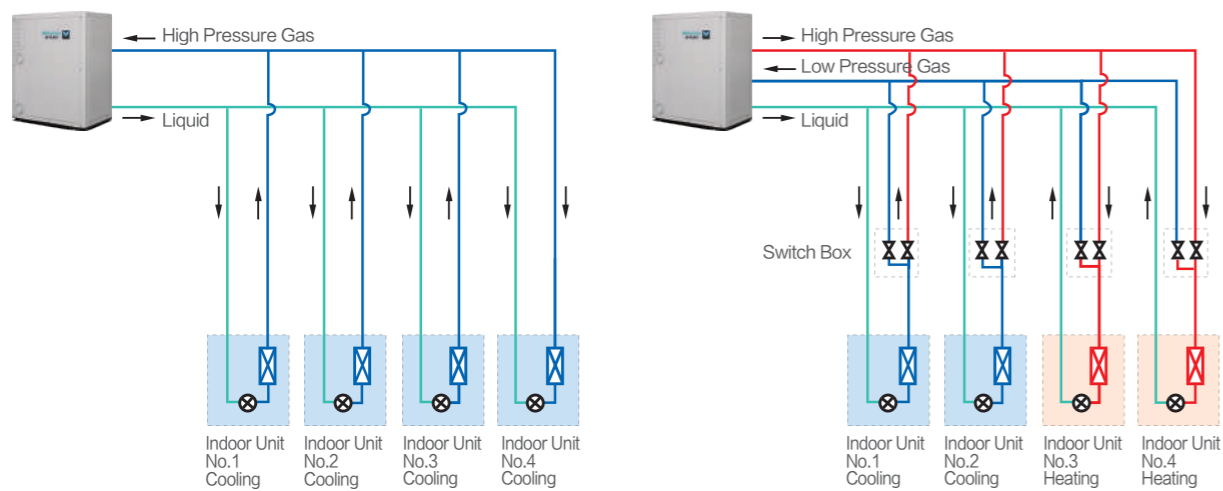

2-stage Heat Recovery

1-stage Heat Recovery

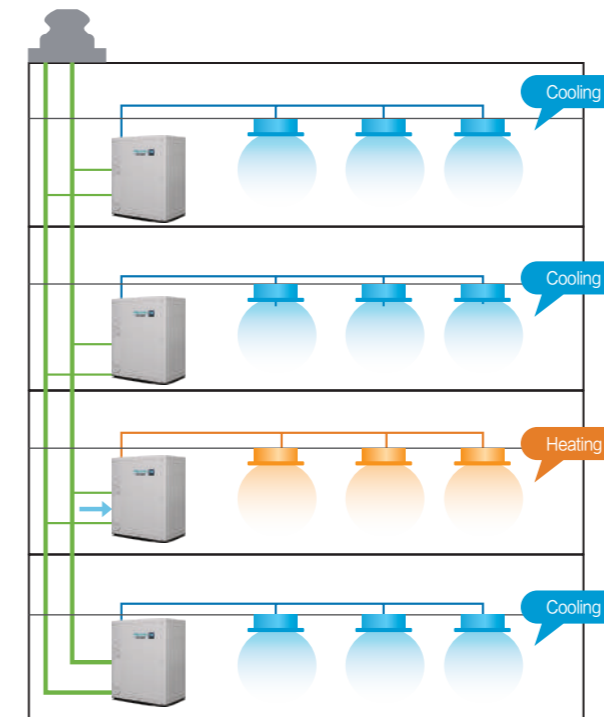

2-stage Heat Recovery

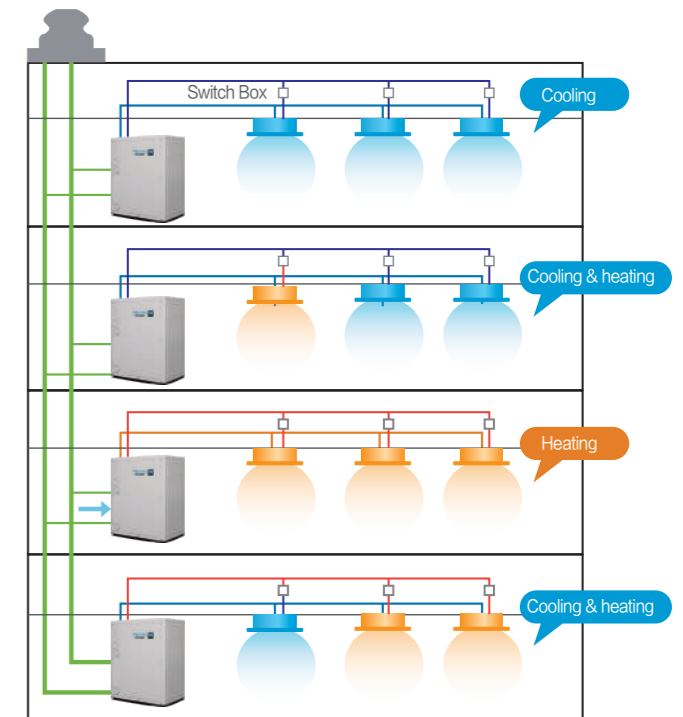

Patented 360° Fitted Refrigerant Cooling Technology

Patented 360° refrigerant cooling technology can help to remove the heat from the main PCB, inverter module and electrical box efficiently, which will greatly improve the reliability of the machine, especially in the high temperature ambient.

- A tin heat conductor is adopted between the refrigerant pipe and the heat sink to increase the heat transfer efficiency.
- The heat sink, made of aluminum alloy with high thermal conductivity, and the refrigerant tube are tightly combined through tube expander to improve heat exchange efficiency.

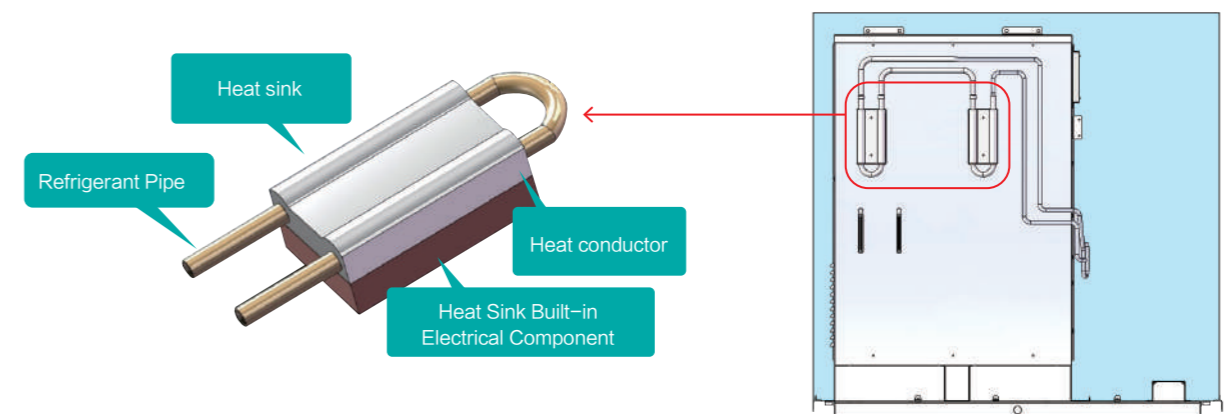

Convenient Installation

The electrical control box window is designed for service engineers to check issues of PCB conveniently. Especially for issues with a high voltage risk of electric shock, it can help engineers to avoid some risks.

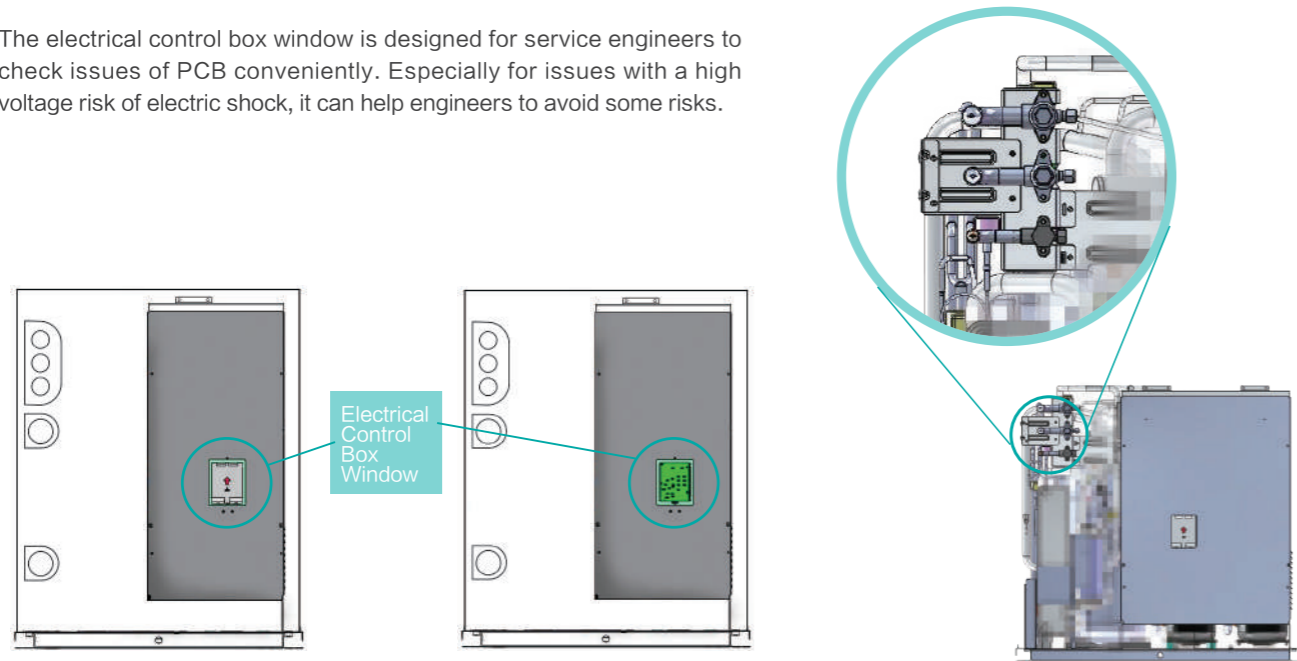

It is very convenient to install and save installation space because of the front outlet pipes.

Indoor Installation, not Affected by Weather Conditions

Indoor installation does not affect the facade of building, and avoids the poor heat dissipation problems which often encountered by many air-cooled outdoor units. Water-cooled efficiency is higher than air-cooled, making the system more energy efficient.

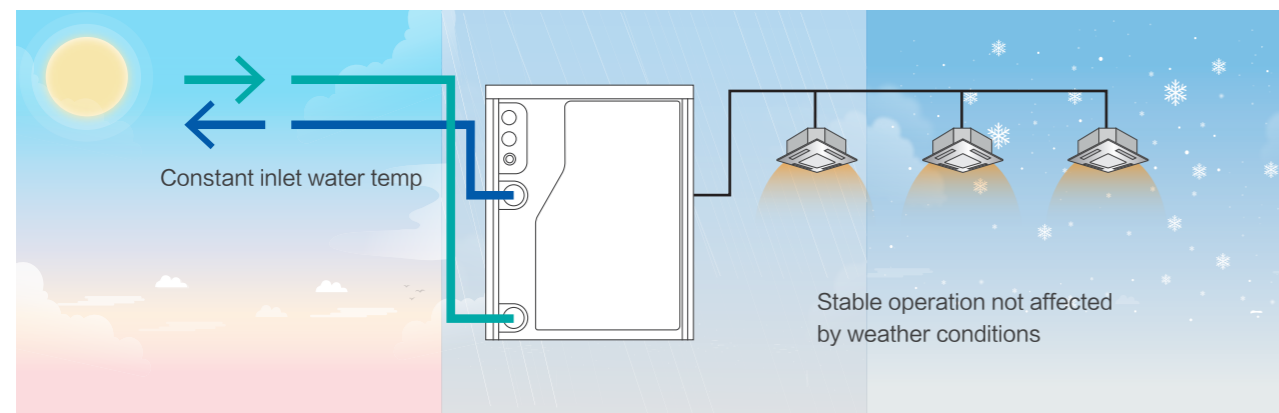

Continuous Heating Without Defrosting Operation

Because the product is generally installed indoors, in heating mode, the cold energy is discharged to the outside through water, which avoids the defrosting problem of air-cooled products.

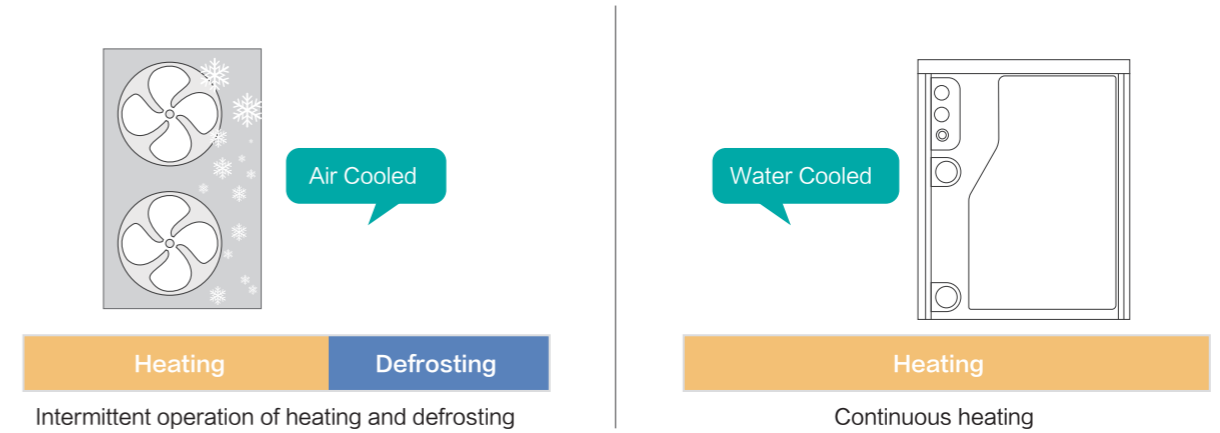

Piping Length

Excellent piping length allows flexible design and installation. As water pipes are not connected to indoor units, users are free from water leakage problems.

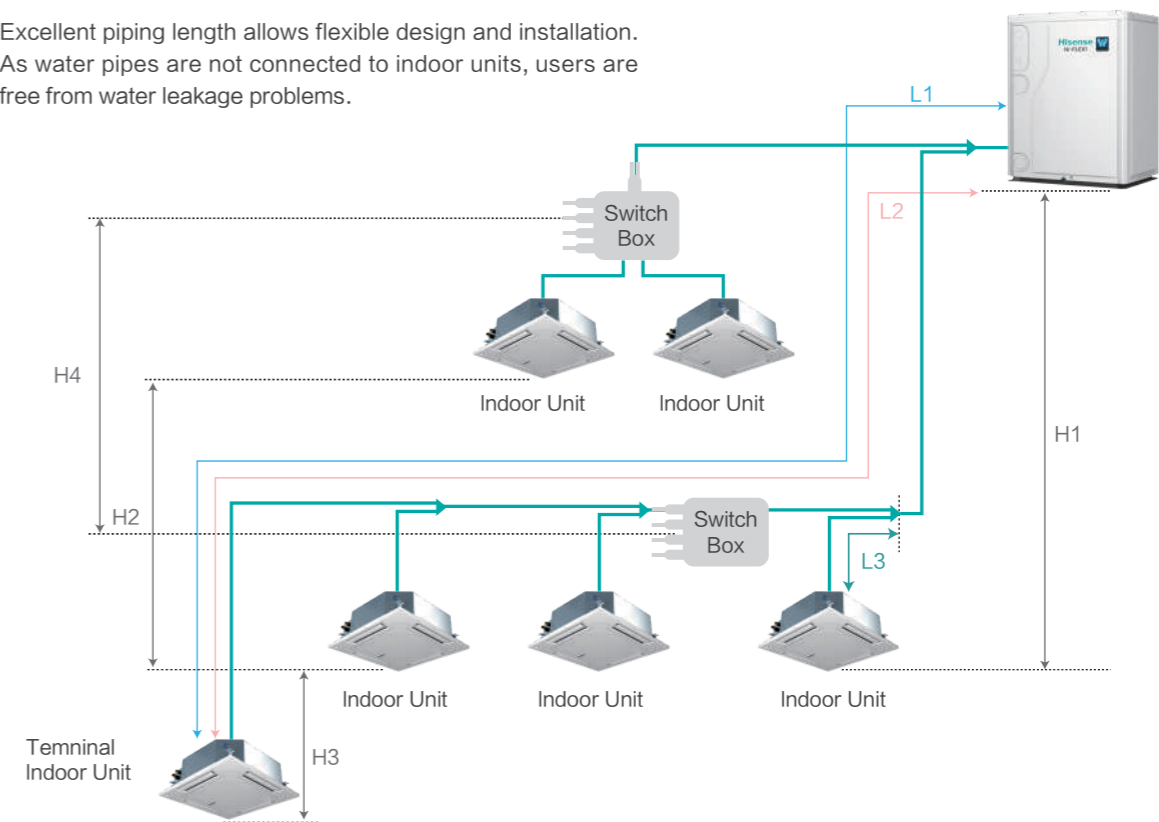

- Max. equivalent pipe length L1: 190m
- Max. pipe length from first branch to each indoor unit L2: 40m
- Max. pipe length from certain branch to the nearby indoor unit L3: 30m
- Height difference between outdoor unit and indoor unit H1: Outdoor unit is higher: 50m, Outdoor unit is lower: 40m
- Height difference between indoor units using the same SW box H3: 4m
- Height difference between SW boxes H4: 5m
- Height difference between indoor units H2: 15m

Multiple Applications

Building Water Loop System

Building water loop system is a common application. The circulating water is heated by boilers during heating mode, and is cooled by the cooling tower during cooling mode to maintain the temperature of the water cycling system.

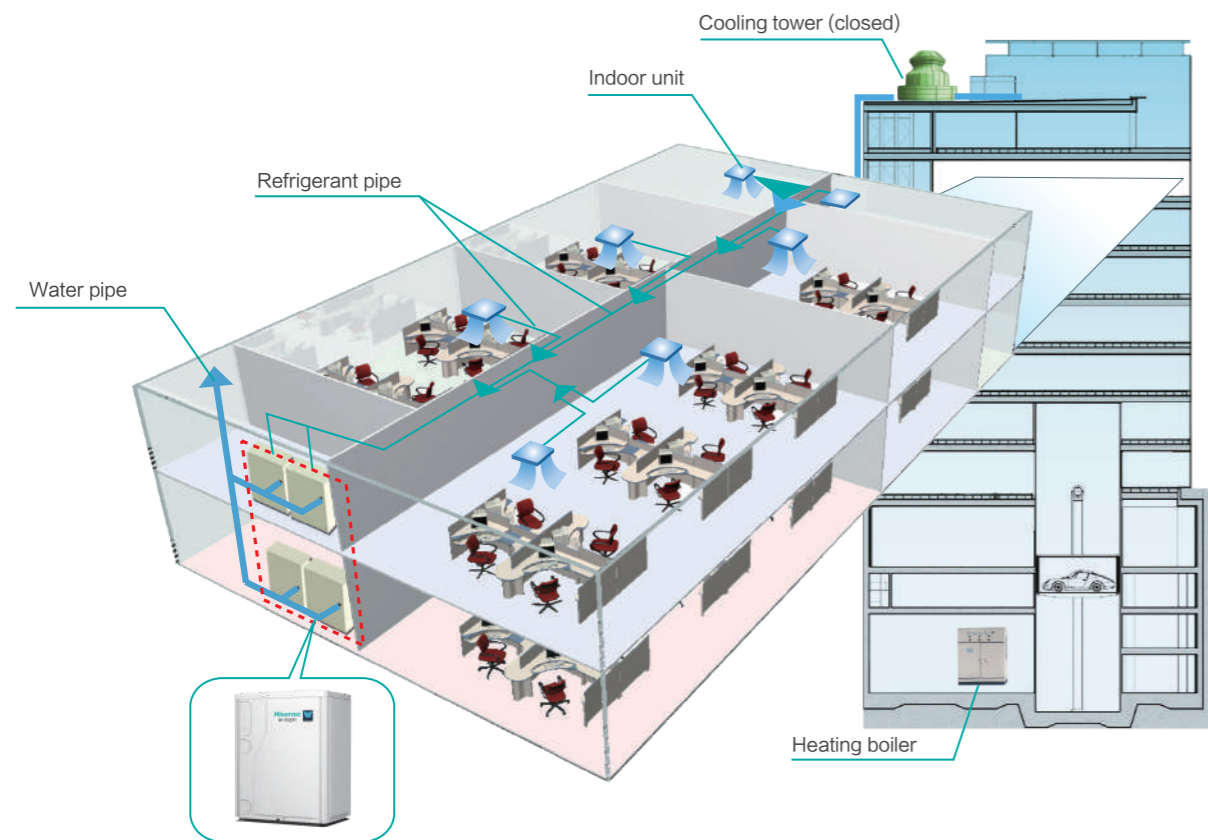

Hi-FLEXi W Series



HP		8HP	10HP	12HP	14HP	
Model	Model	AVWW-76FKFW	AVWW-96FKFW	AVWW-114FKFW	AVWW-136FKFW	
Model	Modules	—	—	—	—	
	Power Supply	AC 3 ϕ , 380-415V/50/60Hz				
Cooling	Capacity	kW	22.4	28.0	33.5	40.0
		kBtu/h	76.5	95.6	114.3	136.5
	Power Input	kW	3.85	5.04	6.32	7.84
	EER	kW/kW	5.82	5.55	5.30	5.10
Heating	Capacity	kW	25.0	31.5	37.5	45.0
		kBtu/h	85.3	107.5	128.0	153.6
	Power Input	kW	4.08	5.25	6.45	8.03
	COP	kW/kW	6.12	6.00	5.81	5.60
Sound	Sound Pressure Level Cooling/Heating	dB(A)	49/51	51/53	53/54	55/57
	Water Temperature	$^{\circ}$ C	10-45	10-45	10-45	10-45
Water-side Heat Exchanger	Rated Water Flow Rate	L/min	76.7	96.0	115.0	138.3
	Water Pressure Drop	kPa	30	45	45	60
	Maximum Pressure Resistance	kgf/cm 2	20	20	20	20
Weight	Net Weight	kg	166	166	171	171
	Gross Weight	kg	170	170	175	175
Dimensions	External (H x W x D)	mm	1030 x 820 x 560	1030 x 820 x 560	1030 x 820 x 560	1030 x 820 x 560
	Packing(H x W x D)	mm	1180 x 900 x 632	1180 x 900 x 632	1180 x 900 x 632	1180 x 900 x 632
Ref. Piping	Liquid Pipe	mm	ϕ 9.53	ϕ 9.53	ϕ 12.70	ϕ 12.70
		inch	3/8	3/8	1/2	1/2
	Low Pressure Gas Pipe	mm	ϕ 19.05	ϕ 22.20	ϕ 25.40	ϕ 25.40
		inch	3/4	7/8	1	1
	High/Low Pressure Gas Pipe	mm	ϕ 15.88	ϕ 19.05	ϕ 22.20	ϕ 22.20
		inch	5/8	3/4	7/8	7/8
Water Connecting Pipes	Water Pipe		DN32	DN32	DN32	DN32
	Thread of Connector		G1-1/4B	G1-1/4B	G1-1/4B	G1-1/4B
	Drain Pipe	mm	Outer Diameter 18	Outer Diameter 18	Outer Diameter 18	Outer Diameter 18
MAX. Connectable Indoor Units	Recommended		12	15	18	21
	Max.		19	24	29	34

Others Applications

Uses underground heat sources like soil, surface water, underground water, seawater, lakes, rivers and more as renewable energy for cooling and heating. Water or antifreeze solution is circulated through the closed loop HDPE (High Density Poly-Ethylene) pipes buried beneath the earth's surface.



Surface water



Seawater



Groud water



Soil source

Hi-FLEXi W Series



Hi-FLEXi W Series



HP		16HP	18HP	20HP
Model	Model	AVWW-154FKFW	AVWW-170FKFW	AVWW-190FKFW
Model	Modules	—	—	—
	Power Supply	AC 3Φ, 380-415V/50/60Hz		
Cooling	Capacity	kW	45.0	50.0
		kBtu/h	153.6	170.6
	Power Input	kW	8.11	9.43
	EER	kW/kW	5.55	5.30
Heating	Capacity	kW	50.0	56.0
		kBtu/h	170.6	191.1
	Power Input	kW	8.33	9.62
	COP	kW/kW	6.00	5.82
Sound	Sound Pressure Level Cooling/Heating	dB(A)	51/52	53/53
	Water Temperature	°C	10-45	10-45
Water-side Heat Exchanger	Rated Water Flow Rate	L/min	153.3	166.7
	Water Pressure Drop	kPa	40	45
	Maximum Pressure Resistance	kgf/cm ²	20	20
Weight	Net Weight	kg	245	246
	Gross Weight	kg	250	251
Dimensions	External (H×W×D)	mm	1030×1040×560	1030×1040×560
	Packing(H×W×D)	mm	1180×1112×632	1180×1112×632
Ref. Piping	Liquid Pipe	mm	φ12.70	φ15.88
		inch	1/2	5/8
	Low Pressure Gas Pipe	mm	φ28.60	φ28.60
		inch	1-1/8	1-1/8
	High/Low Pressure Gas Pipe	mm	φ22.20	φ22.20
		inch	7/8	7/8
Water Connecting Pipes	Water Pipe		DN32	DN32
	Thread of Connector		G1-1/4B	G1-1/4B
	Drain Pipe	mm	Outer Diameter 18	Outer Diameter 18
MAX. Connectable Indoor Units	Recommended		23	26
	Max.		39	43

HP		22HP	24HP	26HP	28HP	30HP
Model	Model	AVWW-210FKFW	AVWW-228FKFW	AVWW-250FKFW	AVWW-268FKFW	AVWW-286FKFW
Model	Modules	AVWW-96FKFW AVWW-114FKFW	AVWW-114FKFW AVWW-114FKFW	AVWW-114FKFW AVWW-136FKFW	AVWW-114FKFW AVWW-154FKFW	AVWW-96FKFW AVWW-190FKFW
	Power Supply	AC 3Φ, 380-415V/50/60Hz				
Cooling	Capacity	kW	61.5	67.0	73.5	78.5
		kBtu/h	209.9	228.6	250.8	267.9
	Power Input	kW	11.4	12.6	14.2	14.4
	EER	kW/kW	5.41	5.30	5.19	5.44
Heating	Capacity	kW	69.0	75.0	82.5	87.5
		kBtu/h	235.4	255.9	281.6	298.6
	Power Input	kW	11.7	12.9	14.5	14.8
	COP	kW/kW	5.90	5.81	5.70	5.92
Sound	Sound Pressure Level Cooling/Heating	dB(A)	56/57	56/57	58/60	56/57
	Water Temperature	°C	10-45	10-45	10-45	10-45
Water-side Heat Exchanger	Rated Water Flow Rate	L/min	211.0	230.0	253.3	268.3
	Water Pressure Drop	kPa	/	/	/	/
	Maximum Pressure Resistance	kgf/cm ²	20	20	20	20
Weight	Net Weight	kg	337	342	342	416
	Gross Weight	kg	345	350	350	425
Dimensions	External (H×W×D)	mm	1030× (820+820) ×560	1030× (820+820) ×560	1030× (820+820) ×560	1030× (820+1040) ×560
	Packing(H×W×D)	mm	1180× (900+900) ×632	1180× (900+900) ×632	1180× (900+900) ×632	1180× (900+1112) ×632
Ref. Piping	Liquid Pipe	mm	φ15.88	φ15.88	φ19.05	φ19.05
		inch	5/8	5/8	3/4	3/4
	Low Pressure Gas Pipe	mm	φ28.60	φ28.60	φ31.75	φ31.75
		inch	1-1/8	1-1/8	1-1/4	1-1/4
	High/Low Pressure Gas Pipe	mm	φ25.40	φ25.40	φ25.40	φ28.60
		inch	1	1	1	1-1/8
Water Connecting Pipes	Water Pipe		DN32	DN32	DN32	DN32
	Thread of Connector		G1-1/4B	G1-1/4B	G1-1/4B	G1-1/4B
	Drain Pipe	mm	Outer Diameter 18	Outer Diameter 18	Outer Diameter 18	Outer Diameter 18
MAX. Connectable Indoor Units	Recommended		33	36	39	40
	Max.		53	58	63	64

Hi-FLEXi W Series



HP		32HP	34HP	36HP	38HP	40HP	
	Model	AVWW-304FKFW	AVWW-326FKFW	AVWW-344FKFW	AVWW-360FKFW	AVWW-380FKFW	
Model	Modules	AVWW-114FKFW	AVWW-136FKFW	AVWW-154FKFW	AVWW-170FKFW	AVWW-190FKFW	
		AVWW-190FKFW	AVWW-190FKFW	AVWW-190FKFW	AVWW-190FKFW	AVWW-190FKFW	
Power Supply		AC 3Φ, 380-415V/50/60Hz					
Cooling	Capacity	89.5	96.0	101.0	106.0	112.0	
		kW					
		kBtu/h	305.4	327.6	344.7	361.7	382.1
	Power Input	17.3	18.8	19.1	20.4	22.0	
	EER	5.17	5.10	5.29	5.19	5.10	
Heating	Capacity	100.5	108.0	113.0	119.0	126.0	
		kW					
		kBtu/h	342.9	368.6	385.6	406.0	429.9
	Power Input	17.3	18.9	19.2	20.5	21.7	
	COP	5.81	5.72	5.89	5.81	5.80	
Sound	Sound Pressure Level Cooling/Heating	56/58	58/60	56/58	56/58	56/58	
		dB(A)					
Water-side Heat Exchanger	Water Temperature	10-45	10-45	10-45	10-45	10-45	
	Rated Water Flow Rate	308.3	331.7	346.7	360.0	386.7	
	Water Pressure Drop	/	/	/	/	/	
	Maximum Pressure Resistance	20	20	20	20	20	
Weight	Net Weight	417	417	491	492	492	
	Gross Weight	426	426	501	502	502	
Dimensions	External (H × W × D)	mm	1030 × (820+1040)	1030 × (820+1040)	1030 × (1040+1040)	1030 × (1040+1040)	
			× 560	× 560	× 560	× 560	
	Packing(H × W × D)	mm	1180 × (900+1112)	1180 × (900+1112)	1180 × (1112+1112)	1180 × (1112+1112)	
			× 632	× 632	× 632	× 632	
Ref. Piping	Liquid Pipe	mm	φ19.05	φ19.05	φ19.05	φ19.05	
		inch	3/4	3/4	3/4	3/4	
	Low Pressure Gas Pipe	mm	φ31.75	φ31.75	φ31.75	φ38.10	φ38.10
		inch	1-1/4	1-1/4	1-1/4	1-1/2	1-1/2
High/Low Pressure Gas Pipe	mm	φ28.60	φ28.60	φ28.60	φ31.75	φ31.75	
	inch	1-1/8	1-1/8	1-1/8	1-1/4	1-1/4	
Water Connecting Pipes	Water Pipe	DN32	DN32	DN32	DN32	DN32	
	Thread of Connector	G1-1/4B	G1-1/4B	G1-1/4B	G1-1/4B	G1-1/4B	
	Drain Pipe	mm	Outer Diameter 18	Outer Diameter 18	Outer Diameter 18	Outer Diameter 18	
MAX. Connectable Indoor Units	Recommended	40	40	40	40	40	
	Max.	64	64	64	64	64	

Hi-FLEXi W Series



HP		42HP	44HP	46HP	48HP	50HP	
	Model	AVWW-400FKFW	AVWW-418FKFW	AVWW-440FKFW	AVWW-456FKFW	AVWW-476FKFW	
Model	Modules	AVWW-96FKFW	AVWW-114FKFW	AVWW-96FKFW	AVWW-96FKFW	AVWW-96FKFW	
		AVWW-114FKFW	AVWW-114FKFW	AVWW-154FKFW	AVWW-170FKFW	AVWW-190FKFW	
		AVWW-190FKFW	AVWW-190FKFW	AVWW-190FKFW	AVWW-190FKFW	AVWW-190FKFW	
Power Supply		AC 3Φ, 380-415V/50/60Hz					
Cooling	Capacity	117.5	123.0	129.0	134.0	140.0	
		kW					
		kBtu/h	401.0	419.7	440.3	457.3	477.7
	Power Input	22.3	23.6	24.1	25.5	27.0	
	EER	5.26	5.21	5.35	5.27	5.19	
Heating	Capacity	132.0	138.0	144.5	150.5	157.5	
		kW					
		kBtu/h	450.4	470.9	493.0	513.5	537.4
	Power Input	22.6	23.8	24.4	25.7	27.0	
	COP	5.85	5.81	5.91	5.85	5.84	
Sound	Sound Pressure Level Cooling/Heating	58/60	58/60	58/60	58/60	58/60	
		dB(A)					
Water-side Heat Exchanger	Water Temperature	10-45	10-45	10-45	10-45	10-45	
	Rated Water Flow Rate	404.3	423.3	442.7	456.0	482.7	
	Water Pressure Drop	/	/	/	/	/	
	Maximum Pressure Resistance	20	20	20	20	20	
Weight	Net Weight	583	588	657	658	658	
	Gross Weight	596	601	671	672	672	
Dimensions	External (H × W × D)	mm	1030 × (820+820+1040)	1030 × (820+820+1040)	1030 × (820+1040+1040)	1030 × (820+1040+1040)	
			× 560	× 560	× 560	× 560	
	Packing(H × W × D)	mm	1180 × (900+900+1112)	1180 × (900+900+1112)	1180 × (900+1112+1112)	1180 × (900+1112+1112)	
			× 632	× 632	× 632	× 632	
Ref. Piping	Liquid Pipe	mm	φ19.05	φ19.05	φ19.05	φ19.05	
		inch	3/4	3/4	3/4	3/4	
	Low Pressure Gas Pipe	mm	φ38.10	φ38.10	φ38.10	φ38.10	
		inch	1-1/2	1-1/2	1-1/2	1-1/2	
High/Low Pressure Gas Pipe	mm	φ31.75	φ31.75	φ31.75	φ31.75		
	inch	1-1/4	1-1/4	1-1/4	1-1/4		
Water Connecting Pipes	Water Pipe	DN32	DN32	DN32	DN32	DN32	
	Thread of Connector	G1-1/4B	G1-1/4B	G1-1/4B	G1-1/4B	G1-1/4B	
	Drain Pipe	mm	Outer Diameter 18	Outer Diameter 18	Outer Diameter 18	Outer Diameter 18	
MAX. Connectable Indoor Units	Recommended	40	40	40	40	40	
	Max.	64	64	64	64	64	

Hi-FLEXi W Series



NOTES:

- Operation condition:
 - Cooling: indoor temperature 27°C DB /19°C WB, water inlet/outlet 30/35°C.
 - Heating: indoor temperature 20°C DB /15°C WB, water inlet 20°C.
- The sound pressure is based on the following conditions.
 - 1 meter from the unit service cover surface, and 1.5 meters from floor level.
 - The above data was measured in an anechoic chamber so that reflected sound should be taken into consideration in the field.
- When unit is operating out of the allowable water temperature range, it won't start normally and will alarm.
- For Max. pipe length more than 300m, please contact with our professional engineer.

HP		52HP	54HP	56HP	58HP	60HP
Model	Model	AVWW-494FKFW	AVWW-516FKFW	AVWW-534FKFW	AVWW-550FKFW	AVWW-570FKFW
	Modules	AVWW-114FKFW	AVWW-136FKFW	AVWW-154FKFW	AVWW-170FKFW	AVWW-190FKFW
		AVWW-190FKFW	AVWW-190FKFW	AVWW-190FKFW	AVWW-190FKFW	AVWW-190FKFW
		AVWW-190FKFW	AVWW-190FKFW	AVWW-190FKFW	AVWW-190FKFW	AVWW-190FKFW
Power Supply		AC 3Φ, 380-415V/50/60Hz				
Cooling	Capacity	145.5	152.0	157.0	162.0	168.0
	Capacity	496.4	518.6	535.7	552.7	573.2
	Power Input	28.3	29.8	30.1	31.4	32.9
	EER	5.14	5.10	5.22	5.16	5.10
Heating	Capacity	163.5	171.0	176.0	182.0	189.0
	Capacity	557.9	583.5	600.5	621.0	644.9
	Power Input	28.2	29.8	30.1	31.3	32.6
Sound	COP	5.80	5.75	5.86	5.81	5.80
	Sound Pressure Level Cooling/Heating	58/60	60/62	58/60	58/60	58/60
Water-side Heat Exchanger	Water Temperature	10-45	10-45	10-45	10-45	10-45
	Rated Water Flow Rate	501.7	525.0	540.0	553.3	580.0
	Water Pressure Drop	/	/	/	/	/
	Maximum Pressure Resistance	20	20	20	20	20
Weight	Net Weight	663	663	737	738	738
	Gross Weight	677	677	752	753	753
Dimensions	External (H × W × D)	1030 × (820+1040+1040) × 560	1030 × (820+1040+1040) × 560	1030 × (1040+1040+1040) × 560	1030 × (1040+1040+1040) × 560	1030 × (1040+1040+1040) × 560
	Packing(H × W × D)	1180 × (900+1112+1112) × 632	1180 × (900+1112+1112) × 632	1180 × (1112+1112+1112) × 632	1180 × (1112+1112+1112) × 632	1180 × (1112+1112+1112) × 632
Ref. Piping	Liquid Pipe	φ19.05 3/4	φ19.05 3/4	φ22.20 7/8	φ22.20 7/8	φ22.20 7/8
	Low Pressure Gas Pipe	φ38.10	φ38.10	φ38.10	φ38.10	φ38.10
		1-1/2	1-1/2	1-1/2	1-1/2	1-1/2
	High/Low Pressure Gas Pipe	φ31.75	φ31.75	φ38.10	φ38.10	φ38.10
1-1/4		1-1/4	1-1/2	1-1/2	1-1/2	
Water Connecting Pipes	Water Pipe	DN32	DN32	DN32	DN32	DN32
	Thread of Connector	G1-1/4B	G1-1/4B	G1-1/4B	G1-1/4B	G1-1/4B
	Drain Pipe	Outer Diameter 18	Outer Diameter 18	Outer Diameter 18	Outer Diameter 18	Outer Diameter 18
MAX. Connectable Indoor Units	Recommended	40	40	40	40	40
	Max.	64	64	64	64	64

INDOOR UNIT

4-Way Cassette Type / Mini 4-Way Cassette Type

1-Way Cassette Type

2-Way Cassette Type

Console Type

Ceiling Ducted Type (AC/DC Low-height)

Ceiling Ducted Type (DC High Static Pressure)

Ceiling Ducted Type (High/Low Static Pressure)

Wall Mounted Type

Ceiling & Floor Type

Floor Concealed Type

All Fresh Air Indoor Unit

Heat Recovery Ventilator

AHU Connection KIT

AIR
CONDITIONING
SOLUTION

Indoor Unit Line-up

HP		0.6	0.8	1.0	1.3	1.5	1.6	1.8	1.9	2.0	2.3	2.5	3.0	3.3	4.0	5.0	6.0	8.0	10.0
kBtu/h		5	7	9	12	14	15	17	18	19	22	24	27	30	38	48	54	76	96
4-Way Cassette Type				•	•		•			•	•	•	•	•	•	•	•		
Mini 4-Way Cassette Type		•	•	•	•		•	•		•									
1-Way Cassette Type			•	•	•	•			•			•							
2-Way Cassette Type			•	•	•	•			•			•	•	•	•	•	•	•	
Console Type		•	•	•	•		•	•											
Ceiling Ducted Type (AC Low-height)		•	•	•	•		•	•		•	•	•							
Ceiling Ducted Type (DC Low-height)		•	•	•	•		•	•		•	•	•							
Ceiling Ducted Type (DC High Static Pressure)			•	•	•		•			•		•		•	•	•	•	•	•
Ceiling Ducted Type (High Static Pressure)			•	•	•		•			•	•	•	•	•	•	•	•	•	•
Ceiling Ducted Type (Low Static Pressure)			•	•	•		•			•	•	•	•	•	•	•	•	•	•
Wall Mounted Type		•	•	•	•		•	•				•	•						
Ceiling & Floor Type									•	•		•	•	•	•	•	•		
Floor Concealed Type				•		•			•			•							

Note: More specific capacity information, please see the introduction of each indoor unit.

RELIABILITY

EFFICIENCY

COMFORT

FLEXIBILITY

OUTDOOR UNIT

INDOOR UNIT

CONTROL SYSTEM

ACCESSORY

Indoor Unit Feature Overview

Type	Accessories								
	Drain Pump (built-in)	3D Airflow Panel	Filter	Humidity Sensor	AirPure Kit	Motion Sensor	Hi-Motion	Outlet Air Temp Sensor	Float Switch
4-Way Cassette Type	●	×	●	○	○	○	○	●	●
Mini 4-Way Cassette Type	●	×	●	○	○	○	○	×	●
1-Way Cassette Type	●	×	●	×	×	×	○	●	●
2-Way Cassette Type	●	×	●	×	×	×	○	●	●
Console Type	×	×	●	○	×	×	○	×	×
Ceiling Ducted Type (AC Low-height)	●	○	●	○	○	×	○	×	●
Ceiling Ducted Type (DC Low-height)	●	○	●	○	○	×	○	×	●
Ceiling Ducted Type(DC High Static Pressure) AVD-07-AVD-54	○	×	●	○	○	×	○	●	●
Ceiling Ducted Type(DC High Static Pressure) AVD-76 & AVD-96	○	×	○	○	○	×	○	●	●
Ceiling Ducted Type (High Static Pressure) AVD-07-AVD-54	○	×	●	○	○	×	○	×	●
Ceiling Ducted Type (High Static Pressure) AVD-76 & AVD-96	×	×	○	×	×	×	○	●	●
Ceiling Ducted Type (Low Static Pressure) AVD-07-AVD-54	○	×	●	○	○	×	○	×	●
Ceiling Ducted Type (Low Static Pressure) AVD-76 & AVD-96	×	×	○	×	×	×	○	●	●
Wall Mounted Type	×	×	●	○	×	×	○	●	×
Ceiling & Floor Type	×	×	●	×	×	×	○	●	×
Floor Concealed Type	×	×	×	×	×	×	○	●	×

Type	Features										
	Dry Contact Input	Windows Linkage	Dry Contact Output	Fresh Air Intake	Sleep	Quiet	ECO	Individual Louver Control	Breeze Mode	Self Cleaning	Auto Fan Speed
4-Way Cassette Type	●	×	●	●	●	●	●	●	●	×	×
Mini 4-Way Cassette Type	●	×	●	●	●	●	●	●	●	×	×
1-Way Cassette Type	●	×	●	●	●	●	●	×	×	×	●
2-Way Cassette Type	●	×	●	●	●	×	×	●	×	×	●
Console Type	●	×	●	●	●	●	●	×	×	×	×
Ceiling Ducted Type (AC Low-height)	●	●	●	●	●	●	●	×	×	×	×
Ceiling Ducted Type (DC Low-height)	●	●	●	●	●	●	●	×	×	×	×
Ceiling Ducted Type (DC High Static Pressure) AVD-07-AVD-54	●	●	●	●	●	●	●	×	×	●	●
Ceiling Ducted Type (DC High Static Pressure) AVD-76 & AVD-96	●	●	●	×	●	●	●	×	×	×	●
Ceiling Ducted Type (High Static Pressure) AVD-07-AVD-54	●	●	●	●	×	×	●	×	×	×	×
Ceiling Ducted Type (High Static Pressure) AVD-76 & AVD-96	●	×	●	×	●	×	●	×	×	×	×
Ceiling Ducted Type (Low Static Pressure) AVD-07-AVD-54	●	●	●	●	×	×	●	×	×	×	×
Ceiling Ducted Type (Low Static Pressure) AVD-76 & AVD-96	●	×	●	×	●	×	●	×	×	×	×
Wall Mounted Type	●	●	●	×	●	●	●	×	×	●	●
Ceiling & Floor Type	●	×	●	×	×	×	×	×	×	×	×
Floor Concealed Type	●	×	●	×	●	●	●	×	×	×	●

Remarks: Standard: ● Optional: ○ Incompatible: ×

Remarks: Standard: ● Optional: ○ Incompatible: ×

RELIABILITY

EFFICIENCY

COMFORT

FLEXIBILITY

OUTDOOR UNIT

INDOOR UNIT

CONTROL SYSTEM

ACCESSORY

4-Way Cassette Type Mini 4-Way Cassette Type

Compact and Classy Design

The 4-way cassette is now as slim as 238mm and 215mm for mini 4-way cassettes, fit for narrow ceiling spaces. Boring straight return air grille patterns are replaced with exquisite hexagon pattern design, upgrading taste and classiness of any interior aesthetic.

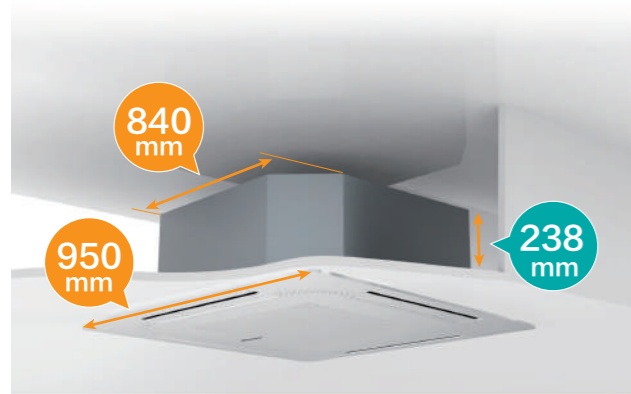

4-way Cassette Type

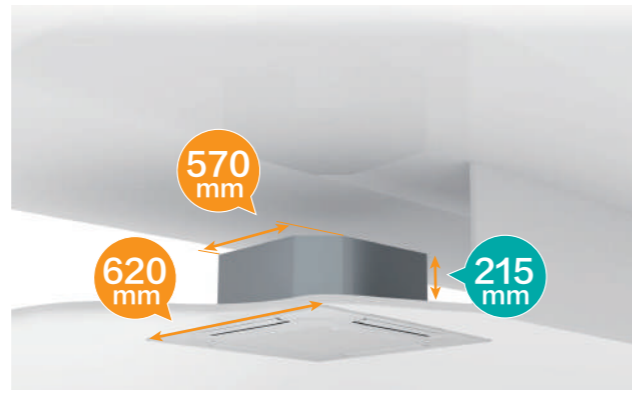

Mini 4-way Cassette Type

Higher Installation

Air from the cassette still manages to flow down from ceiling heights as high as 4.2m. Not to mention human presence and density detection by motion sensor at such height.

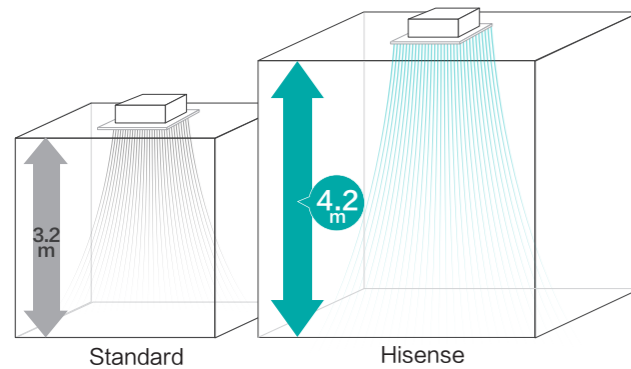

Standard

Hisense

Breeze Mode

Under the new designed breeze mode, the cold air is blown out from the microholes in the panel, and the unit is working in a mute mode, which can avoid blowing air directly on people and achieve more even and comfortable airflow.

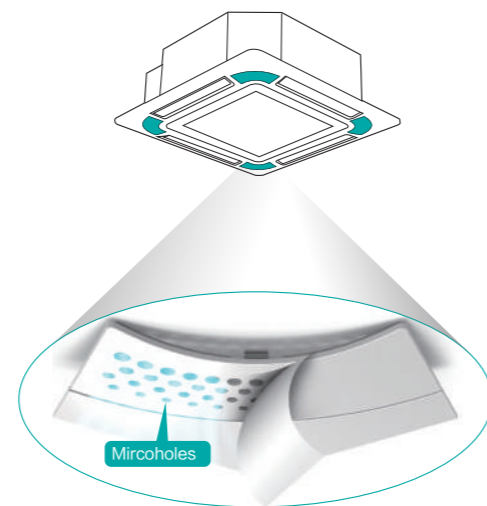

Microholes

Individual Louvers Control

4-way cassettes louvers are now capable of individual control to freely choose how you want your AC unit supplies air according to different needs, applications and installation layout. Each louvers have 7 angle settings and maximum angle reach at 64°.

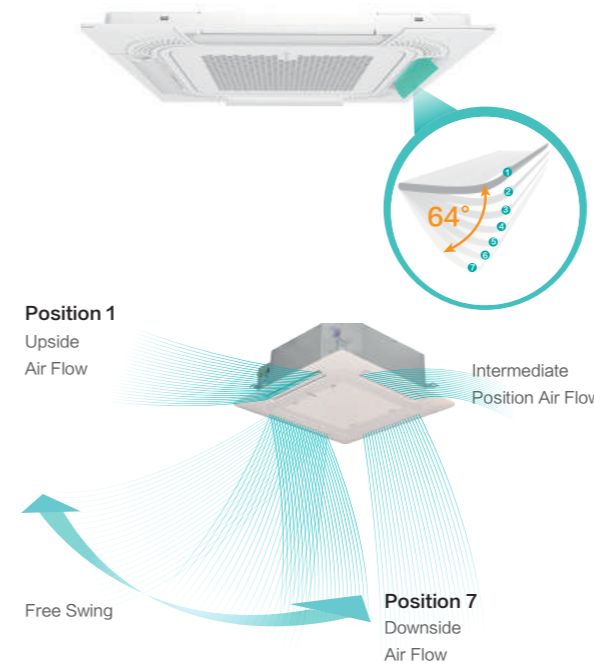

AirPure

AirPure is a healthy alternative accessory to the normal conventional cassette unit to improve overall air quality. Airpure helps in improving skin condition, effective deodorizer and deactivating bacteria, virus and allergens floating in the air.

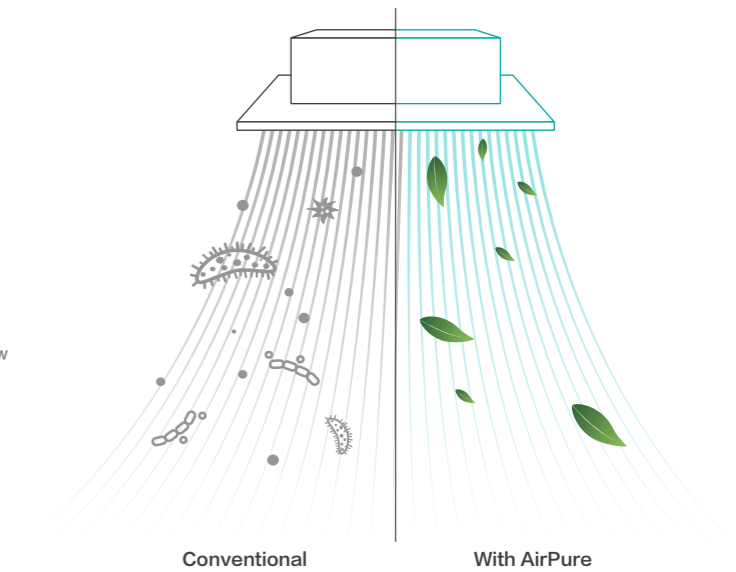

Conventional

With AirPure

Motion Sensor

The sensor senses the presence of people to automatically turn the cassette unit on or off and whether to direct airflow towards or avoiding humans depend settings set on the controller. During crowded times, the setting temperature is automatically lowered down and vice versa. Meeting comfort and using energy only when necessary.

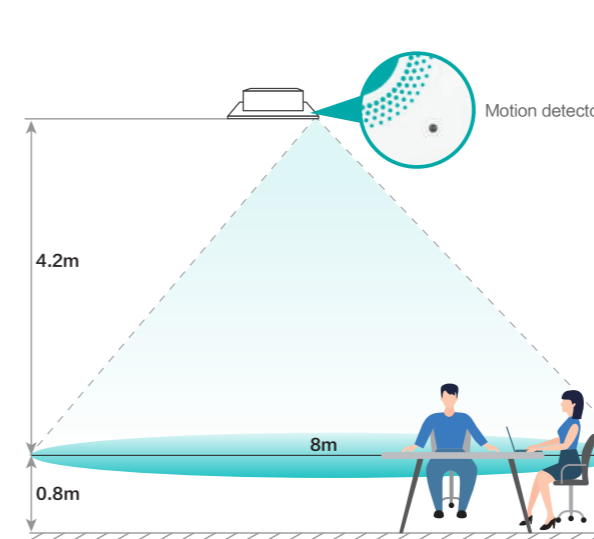

Motion detector

4.2m

8m

0.8m

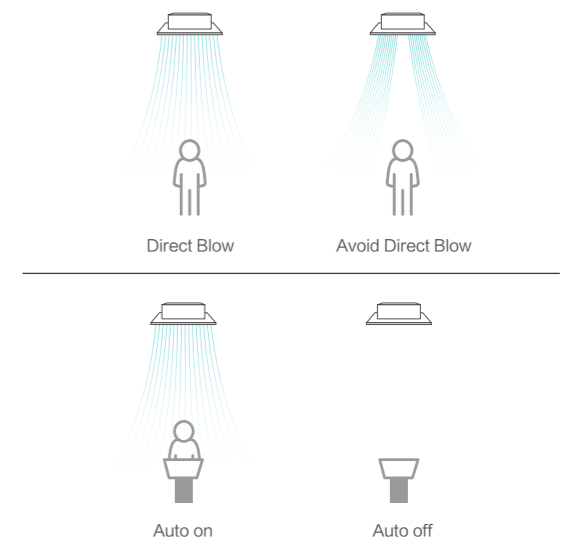

Direct Blow

Avoid Direct Blow

Auto on

Auto off

4-Way Cassette Type



Model		AVBC-09 HJFKA	AVBC-12 HJFKA	AVBC-15 HJFKA	AVBC-19 HJFKA	AVBC-22 HJFKA	AVBC-24 HJFKA	AVBC-27 HJFKA	AVBC-30 HJFKA	AVBC-38 HJFKA	AVBC-48 HJFKA	AVBC-54 HJFKA	
Power Supply		AC 1 φ, 220-240V/50Hz/60Hz											
Capacity	Cooling	kW	2.8	3.6	4.5	5.6	6.3	7.1	8.0	9.0	11.2	14.0	16.0
		Btu/h	9,600	12,300	15,400	19,100	21,500	24,200	27,300	30,700	38,200	47,800	54,600
	Heating	kW	3.2	4.0	5.0	6.3	7.1	8.0	9.0	10.0	12.5	16.0	18.0
		Btu/h	10,900	13,700	17,100	21,500	24,200	27,300	30,700	34,100	42,700	54,600	61,400
Power Input	Cooling	W	14	24	24	34	54	64	54	54	124	124	124
	Heating	W	14	24	24	34	54	64	54	54	124	124	124
Sound Pressure	dB(A)	30/28/28/ 27/26/26	32/29/29/ 28/27/26	33/31/29/ 29/27/26	34/31/30/ 28/28/26	36/33/32/ 31/29/28	36/33/32/ 31/29/28	37/36/35/ 33/31/30	37/36/35/ 33/31/30	42/40/38/ 36/34/33	46/44/40/ 38/36/34	46/44/41/ 40/38/36	
Airflow Rate	m ³ /min	15.0/13.4/ 10.0/8.8	17.0/14.0/ 10.8/9.1	21.0/16.0/ 14.9/13.6	22.0/17.5/ 15.9/15.5	26.0/20.0/ 18.3/17.0	27.0/21.0/ 19.1/18.0	27.0/22.0/ 20.3/18.7	27.0/23.0/ 20.7/19.6	37.0/30.0/ 27.4/24.8	37.0/33.5/ 29.6/27.2	37.0/34.0/ 30.7/28.9	
		12.0/10.8/ 10.0/8.8	12.8/11.8/ 10.8/9.1	14.9/13.6/ 12.7/11.2	15.9/15.5/ 13.6/12.5	18.3/17.0/ 15.1/13.0	19.1/18.0/ 16.3/14.7	20.3/18.7/ 16.8/15.4	20.7/19.6/ 17.7/16.1	27.4/24.8/ 22.4/19.6	29.6/27.2/ 24.5/22.4	30.7/28.9/ 25.6/23.8	
Piping	Connection Type	-	Flare-nut Connection (with Flare Nuts)										
	Liquid	mm	φ6.35	φ6.35	φ6.35	φ6.35	φ6.35	φ9.53	φ9.53	φ9.53	φ9.53	φ9.53	φ9.53
		inch	1/4	1/4	1/4	1/4	1/4	3/8	3/8	3/8	3/8	3/8	3/8
	Gas	mm	φ12.70	φ12.70	φ12.70	φ12.70	φ12.70	φ15.88	φ15.88	φ15.88	φ15.88	φ15.88	φ15.88
		inch	1/2	1/2	1/2	1/2	1/2	5/8	5/8	5/8	5/8	5/8	5/8
Condensate Drain	mm	O.D.32											
Weight	Net Weight	kg	20	20	21	21	23	23	26	26	26	26	26
	Gross Weight	kg	24	24	25	25	27	27	31	31	31	31	31
Dimensions	External	H mm	238	238	238	238	238	238	288	288	288	288	288
		W mm	840	840	840	840	840	840	840	840	840	840	840
		D mm	840	840	840	840	840	840	840	840	840	840	840
		H mm	292	292	292	292	292	292	342	342	342	342	342
	Packaging	W mm	945	945	945	945	945	945	945	945	945	945	945
		D mm	945	945	945	945	945	945	945	945	945	945	945
		Model	-	HP-G-NK	HP-G-NK	HP-G-NK	HP-G-NK	HP-G-NK	HP-G-NK	HP-G-NK	HP-G-NK	HP-G-NK	HP-G-NK
		Panel Colour	-	Neutral White									
Decorations	Body	H mm	47	47	47	47	47	47	47	47	47	47	47
		W mm	950	950	950	950	950	950	950	950	950	950	950
		D mm	950	950	950	950	950	950	950	950	950	950	950
	Panel	Packaging	H mm	105	105	105	105	105	105	105	105	105	105
Dimensions		W mm	1014	1014	1014	1014	1014	1014	1014	1014	1014	1014	
		D mm	1014	1014	1014	1014	1014	1014	1014	1014	1014	1014	
	Net Weight	kg	5.7	5.7	5.7	5.7	5.7	5.7	5.7	5.7	5.7	5.7	
	Gross Weight	kg	8	8	8	8	8	8	8	8	8	8	

Notes:

- The nominal cooling capacity and heating capacity are based on following conditions:
Cooling Operation Conditions
Indoor Air Inlet Temperature: 27°C DB (80°F DB), 19.0°C WB (66.2°F WB)
Outdoor Air Inlet Temperature: 35°C DB (95°F DB)
Piping Length: 7.5 Meters Piping Lift: 0 Meter
Heating Operation Conditions
Indoor Air Inlet Temperature: 20°C DB (68°F DB)
Outdoor Air Inlet Temperature: 7°C DB (45°F DB), 6°C WB (43°F WB)
- The sound pressure level is based on following conditions: 1.5m beneath the unit.
The above data was measured in an anechoic chamber so that reflected sound should be taken into consideration in the field.

Mini 4-Way Cassette Type

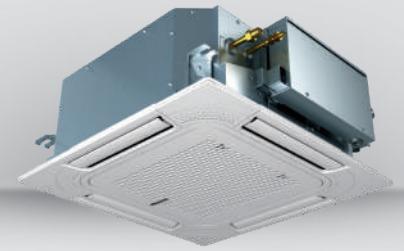

Model		AVC-05HJFA	AVC-07HJFA	AVC-09HJFA	AVC-12HJFA	AVC-15HJFA	AVC-17HJFA	AVC-19HJFA		
Power Supply		AC 1 φ, 220-240V/50Hz/60Hz								
Capacity	Cooling	kW	1.5	2.2	2.8	3.6	4.5	5.0	5.6	
		Btu/h	5,100	7,480	9,520	12,240	15,300	17,000	19,040	
	Heating	kW	2.0	2.5	3.3	4.2	5.0	5.6	6.3	
		Btu/h	6,800	8,500	11,220	14,280	17,000	19,040	21,420	
Power Input	Cooling	W	14	14	14	16	22	30	40	
	Heating	W	14	14	14	16	22	30	40	
Sound Pressure	dB(A)	30/29/28/26	30/29/28/26	32/30/28/26	34/32/29/26	38/36/31/28	42/39/36/31	45/42/38/34		
Airflow Rate	m ³ /min	7.2/6.5/6.2/5.6	7.2/6.5/6.2/5.6	7.8/7.2/6.5/5.8	8.2/7.2/6.5/5.8	9.3/8.7/7.1/6.7	11.0/9.5/8.7/7.1	12.5/10.8/9.3/8.0		
Piping	Connection Type	-	Flare-nut Connection (with Flare Nuts)							
	Liquid	mm	φ6.35	φ6.35	φ6.35	φ6.35	φ6.35	φ6.35	φ6.35	
		inch	1/4	1/4	1/4	1/4	1/4	1/4	1/4	
	Gas	mm	φ12.70	φ12.70	φ12.70	φ12.70	φ12.70	φ12.70	φ12.70	
		inch	1/2	1/2	1/2	1/2	1/2	1/2	1/2	
Condensate Drain	mm	O.D.32								
Weight	Net Weight	kg	14.5	14.5	14.8	14.8	15.8	15.8	15.8	
	Gross Weight	kg	17.3	17.3	17.6	17.6	18.6	18.6	18.6	
Dimensions	External	H mm	215	215	215	215	215	215	215	
		W mm	570	570	570	570	570	570	570	
		D mm	570	570	570	570	570	570	570	
		H mm	292	292	292	292	292	292	292	
	Packaging	W mm	668	668	668	668	668	668	668	
		D mm	730	730	730	730	730	730	730	
		Model	-	HPE-D-NK	HPE-D-NK	HPE-D-NK	HPE-D-NK	HPE-D-NK	HPE-D-NK	HPE-D-NK
		Panel Colour	-	Neutral White						
Decorations	Body	H mm	37	37	37	37	37	37	37	
		W mm	620	620	620	620	620	620	620	
		D mm	620	620	620	620	620	620	620	
	Panel	Packaging	H mm	115	115	115	115	115	115	115
Dimensions		W mm	680	680	680	680	680	680	680	
		D mm	690	690	690	690	690	690		
	Net Weight	kg	2.7	2.7	2.7	2.7	2.7	2.7	2.7	
	Gross Weight	kg	4.5	4.5	4.5	4.5	4.5	4.5	4.5	

Notes:

- The nominal cooling capacity and heating capacity are based on following conditions:
Cooling Operation Conditions
Indoor Air Inlet Temperature: 27°C DB (80°F DB), 19.0°C WB (66.2°F WB)
Outdoor Air Inlet Temperature: 35°C DB (95°F DB)
Piping Length: 7.5 Meters Piping Lift: 0 Meter
Heating Operation Conditions
Indoor Air Inlet Temperature: 20°C DB (68°F DB)
Outdoor Air Inlet Temperature: 7°C DB (45°F DB), 6°C WB (43°F WB)
- The sound pressure level is based on following conditions: 1.5m beneath the unit.
The above data was measured in an anechoic chamber so that reflected sound should be taken into consideration in the field.

2-Way Cassette Type

Compact and Classy Design

The slim structure of the cassette having height as low as 298mm can be installed in ceiling spaces with a minimum of 310mm. Narrow corridors or zoned spaces are best fitted with 2 way cassette due to its compact design.

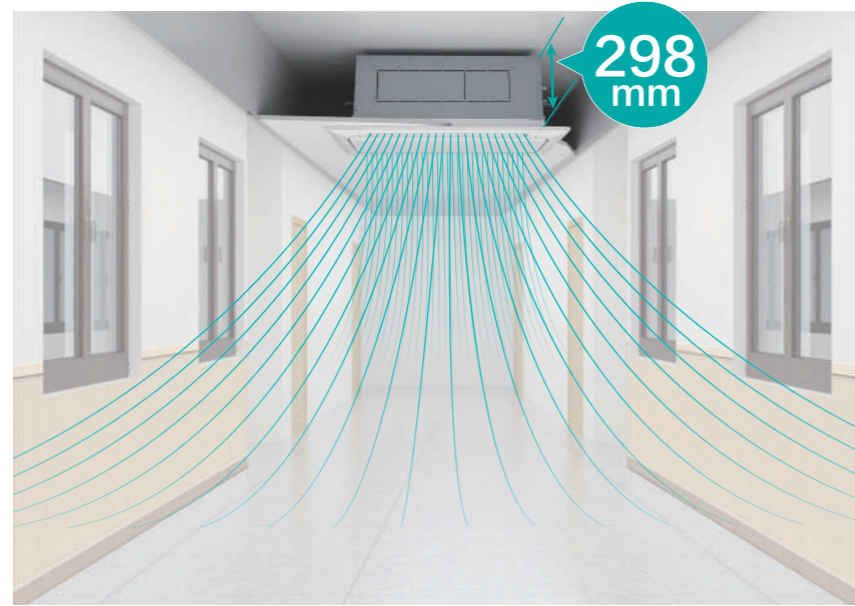

Independent Louvers Control

Each louver's opening angles are controllable individually with a total of 7 choices, with opening angle from 27° to 84° to cover high ceiling narrow long corridors needs and effective warm air supply during winter seasons.

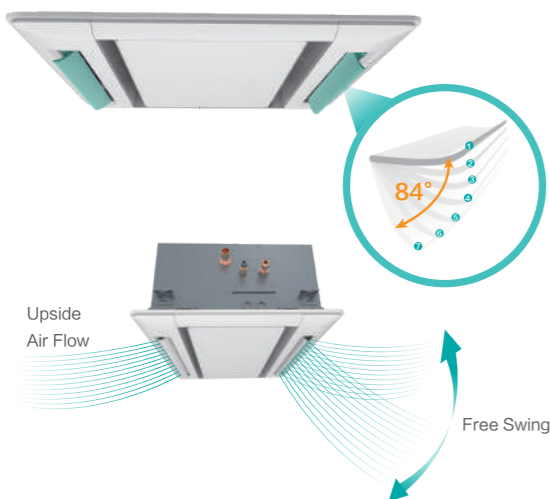

Branch Discharge Option

In irregular room layouts, branch discharge could come in handy by extending air distribution area to the most awkward corners without additional indoor units.

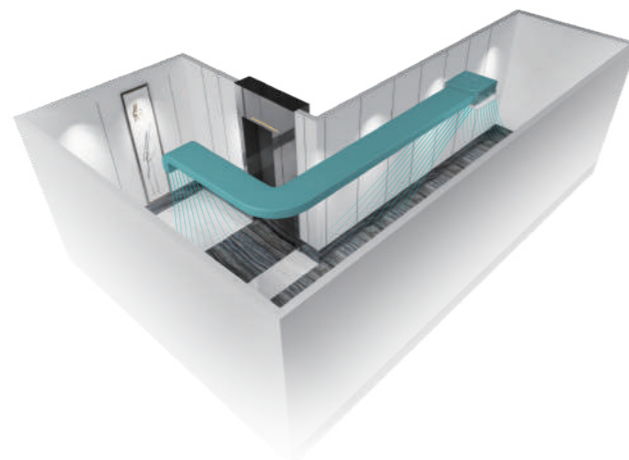

2-Way Cassette Type



Model		AVL-07 UXJSGA	AVL-09 UXJSGA	AVL-12 UXJSGA	AVL-14 UXJSGA	AVL-18 UXJSGA	AVL-24 UXJSGA	AVL-27 UXJSGA	AVL-30 UXJSGA	AVL-38 UXJSHA	AVL-48 UXJSHA	AVL-54 UXJSHA	
Power Supply		AC 1Φ, 220-240V/50Hz/60Hz											
Capacity	Cooling	kW	2.2	2.8	3.6	4.3	5.6	7.1	8.4	9.0	11.2	14.0	16.0
		Btu/h	7,500	9,600	12,300	14,700	19,100	24,200	28,700	30,700	38,200	47,800	54,600
	Heating	kW	2.8	3.3	4.0	4.9	6.5	8.0	9.0	10.0	13.0	16.0	18.0
		Btu/h	9,600	11,300	13,600	16,700	22,200	27,300	30,700	34,100	44,400	54,600	61,400
Power Input	Cooling	W	14	14	14	24	34	44	64	74	84	104	114
	Heating	W	14	14	14	24	34	44	64	74	84	104	114
Sound Pressure		dB(A)	32/30/ 29/27	33/30/ 29/28	34/31/ 30/28	40/37/ 34/32	42/39/ 36/33	45/42/ 40/36	47/44/ 40/36	49/46/ 42/37	46/44/ 40/38	48/45/ 42/38	49/46/ 43/40
	Airflow Rate	m ³ /min	10.0/8.5/ 7.2/6.0	11.0/9.4/ 8.2/6.6	12.0/10.5/ 8.9/7.5	15.0/13.2/ 11.5/9.9	17.0/14.9/ 13.0/11.2	19.0/16.4/ 14.3/12.3	21.0/18.4/ 15.6/12.6	22.0/19.3/ 16.3/13.1	30.0/26.4/ 23.1/19.8	35.0/30.8/ 26.9/21.1	37.0/32.5/ 28.4/24.1
Connection Type			Flare-nut Connection (with Flare Nuts)										
Piping	Liquid	mm	φ6.35	φ6.35	φ6.35	φ6.35	φ6.35	φ9.53	φ9.53	φ9.53	φ9.53	φ9.53	φ9.53
		inch	1/4	1/4	1/4	1/4	1/4	3/8	3/8	3/8	3/8	3/8	3/8
	Gas	mm	φ12.70	φ12.70	φ12.70	φ12.70	φ12.70	φ15.88	φ15.88	φ15.88	φ15.88	φ15.88	φ15.88
		inch	1/2	1/2	1/2	1/2	1/2	5/8	5/8	5/8	5/8	5/8	5/8
Condensate Drain	mm	I.D.32											
Weight	Net Weight	kg	22	22	22	24	24	24	24	24	39	39	39
	Gross Weight	kg	28	28	28	30	30	30	30	30	47	47	47
Dimensions	External	H mm	298	298	298	298	298	298	298	298	298	298	298
		W mm	860	860	860	860	860	860	860	860	1420	1420	1420
		D mm	630	630	630	630	630	630	630	630	630	630	630
	Packaging	H mm	350	350	350	350	350	350	350	350	350	350	350
		W mm	1070	1070	1070	1070	1070	1070	1070	1070	1630	1630	1630
		D mm	710	710	710	710	710	710	710	710	710	710	710
Model		HP-C-NA	HP-C-NA	HP-C-NA	HP-C-NA	HP-C-NA	HP-C-NA	HP-C-NA	HP-C-NA	HP-F-NA	HP-F-NA	HP-F-NA	
Panel Colour		Neutral White											
Decoration Panel	Body Dimensions	H mm	30	30	30	30	30	30	30	30	30	30	30
		W mm	1100	1100	1100	1100	1100	1100	1100	1100	1660	1660	1660
		D mm	710	710	710	710	710	710	710	710	710	710	710
	Packaging Dimensions	H mm	160	160	160	160	160	160	160	160	160	160	160
		W mm	1170	1170	1170	1170	1170	1170	1170	1170	1710	1710	1710
		D mm	740	740	740	740	740	740	740	740	740	740	740
Net Weight	kg	7.5	7.5	7.5	7.5	7.5	7.5	7.5	7.5	10.5	10.5	10.5	
Gross Weight	kg	13.3	13.3	13.3	13.3	13.3	13.3	13.3	13.3	17.8	17.8	17.8	

Notes:

1. The nominal cooling capacity is based on the following conditions:
 Indoor Air Inlet Temperature: 27°C DB (80°F DB), 19.0°C WB (66.2°F WB)
 Outdoor Air Inlet Temperature: 35°C DB (95°F DB)
 Piping Length: 7.5 Meters Piping Lift: 0 Meter

2. The sound pressure level is based on the following conditions: 1.5m beneath the unit.
 The above data was measured in an anechoic chamber so that the reflected sound should be taken into consideration in the field.

Console Type



Stylish Design

With smooth white cover, LED shown and temperature display, the console unit is an super stylish air-conditioning, which is suitable for the residential or commercial applications which need an unit installed on or close to the floor.

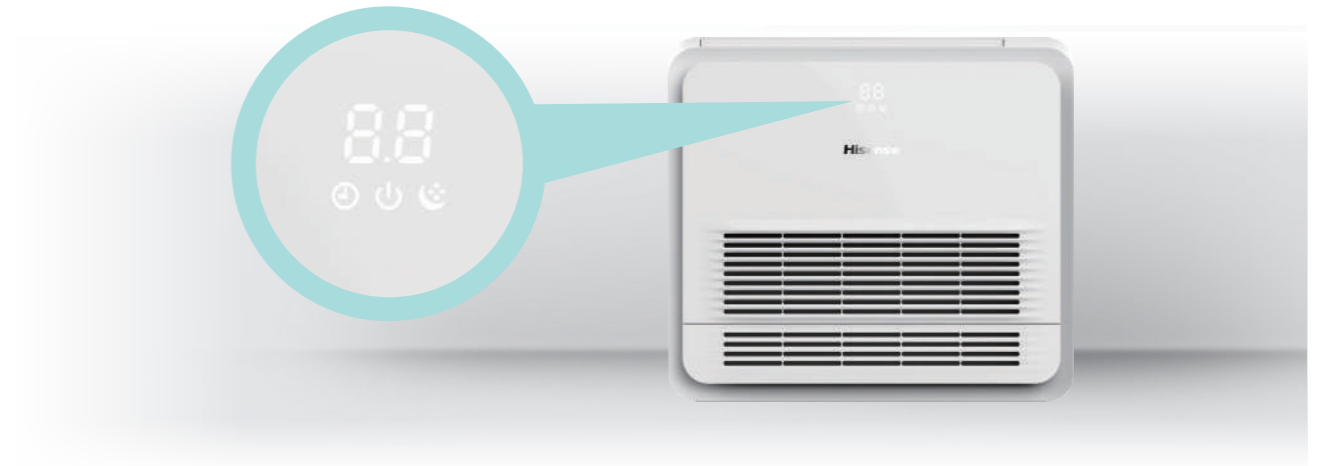

Multiple Blowing Types

Cooling Mode

The unit adopts the stereo cooling mode that can reach the setting temperature rapidly.



*Note: During cooling mode, the lower air louver will close automatically after the indoor unit operates in low fan speed mode for an hour. Otherwise it will keep open.

Heating Mode

Air supply through the below louver achieves floor heating effect and increases the comfortability.



*Note: In the Eco mode, when the indoor return air temp. is close to the setting temp., the upper air deflector is automatically closed, and the lower air outlet mode is activated.

Flexible Installation Options

The unit can stand directly on the floor, or be hanged on the wall. According to the interior decoration style, the machine can choose surface mounted, embedded mounted, concealed mounted.



Standing on the floor



Hanging on the wall

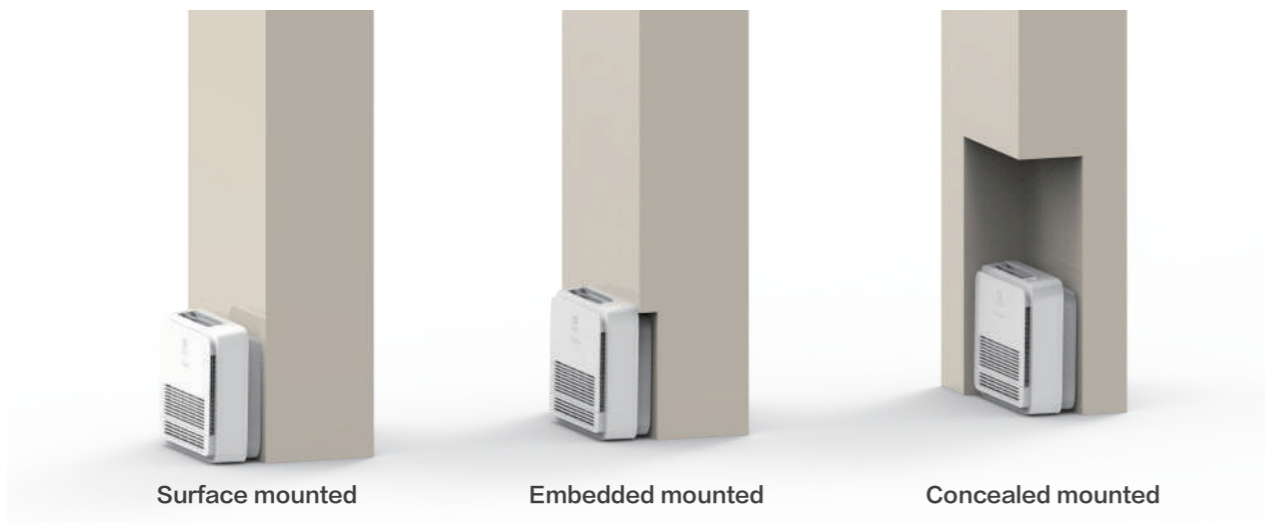

Surface mounted

Embedded mounted

Concealed mounted

Flexible Piping Connection

Both refrigerant and drainage pipings are freely to connect in any direction including two sides (L or R) and bottom and back. An additional direction to the back of the unit suitable for pipes which passing through walls.

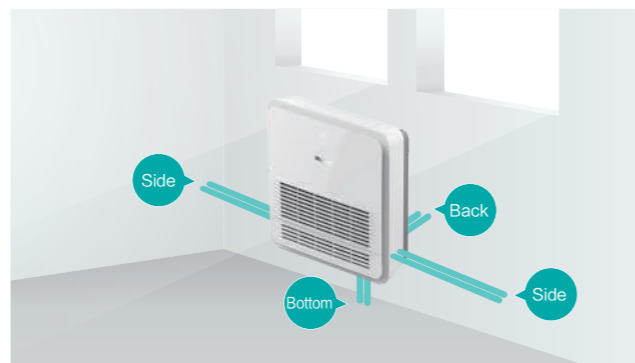

Console Type



Model		AVK-05HJFCAA	AVK-07HJFCAA	AVK-09HJFCAA	AVK-12HJFCAA	AVK-15HJFCAA	AVK-17HJFCAA	
Power Supply		AC 1Φ, 220V-240V/50Hz/60Hz						
Capacity	Cooling	kW	1.5	2.2	2.8	3.6	4.5	5.0
		Btu/h	5,100	7,500	9,600	12,300	15,300	17,000
	Heating	kW	2.0	2.5	3.3	4.2	5.0	5.6
		Btu/h	6,800	8,500	11,200	14,300	17,000	19,100
Power Input	Cooling	W	10	11	12	14	18	23
	Heating	W	10	11	12	14	18	23
Sound Pressure	dB(A)	32/30/29/28/26/24	34/32/31/29/27/26	36/35/32/31/29/27	39/36/34/31/29/27	41/39/37/35/33/32	44/43/41/39/37/36	
Airflow Rate		6.0/5.7/5.3/	7.4/7.0/6.4/	8.0/7.4/7.0/	8.2/7.6/6.8/	9.0/8.5/7.8/	10.1/9.7/9.0/	
		5.1/4.7/4.5	6.0/5.6/5.3	6.4/6.0/5.6	6.2/5.7/5.3	7.2/6.6/6.4	8.5/7.9/7.3	
Panel Colour	-	Pure White	Pure White	Pure White	Pure White	Pure White	Pure White	
Piping	Connection Type	-	Flare-nut Connection (with Flare Nuts)					
	Liquid	mm	φ 6.35	φ 6.35	φ 6.35	φ 6.35	φ 6.35	φ 6.35
		inch	1/4	1/4	1/4	1/4	1/4	1/4
	Gas	mm	φ 12.70	φ 12.70	φ 12.70	φ 12.70	φ 12.70	φ 12.70
		inch	1/2	1/2	1/2	1/2	1/2	1/2
	Condensate Drain	mm	O.D.18					
Weight	Net Weight	kg	16.1	16.1	16.1	17.4	17.4	17.4
	Gross Weight	kg	20.6	21.1	21.1	21.5	21.5	21.5
Dimensions	External	H mm	630	630	630	630	630	630
		W mm	700	700	700	700	700	700
		D mm	225	225	225	225	225	225
	Packaging	H mm	725	725	725	725	725	725
		W mm	790	790	790	790	790	790
		D mm	315	315	315	315	315	315

Notes:

- The nominal cooling capacity and heating capacity are based on the following conditions:
 Cooling Operation Conditions
 Indoor Air Inlet Temperature: 27°C DB (80°F DB), 19.0°C WB (66.2°F WB)
 Outdoor Air Inlet Temperature: 35°C DB (95°F DB)
 Piping Length: 7.5 Meters Piping Lift: 0 Meter
 Heating Operation Conditions
 Indoor Air Inlet Temperature: 20°C DB (68°F DB)
 Outdoor Air Inlet Temperature: 7°C DB (45°F DB), 6°C WB (43°F WB)

- The sound pressure level is based on following conditions:
 It is measured in anechoic room. Operation noise differs with operation and ambient conditions.
 Location of Microphone:

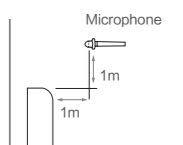

Ceiling Ducted Type (AC/DC Low Height)

Space Saving

Concealed AC/DC Low Height Ducted unit is as slim as 192mm, fitting into the narrowest ceiling spaces. Save ceiling spaces for higher room height without compromising user's comfort and satisfaction.

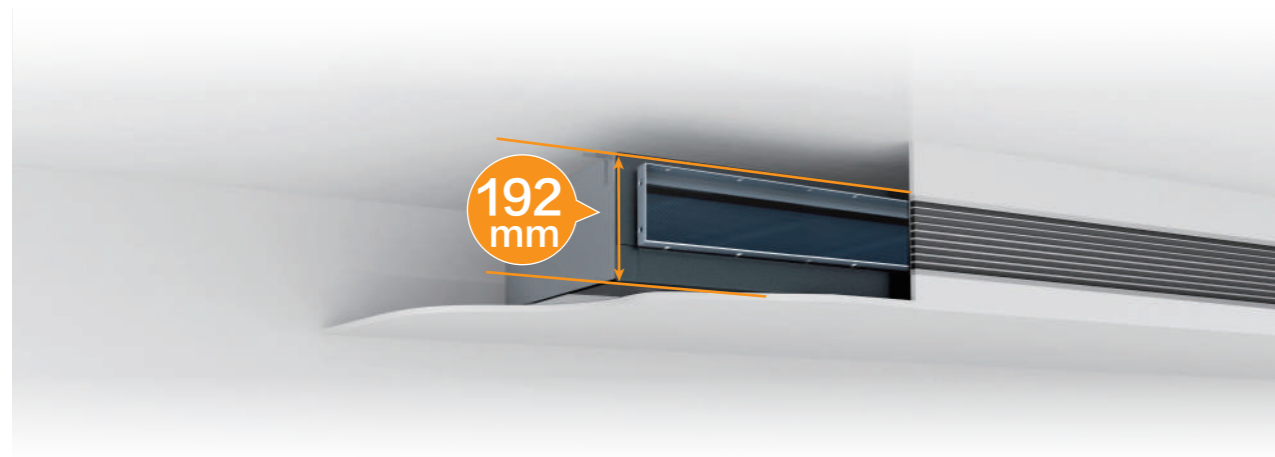

3D Air Flow

Classy air discharge louver panel with LED temperature and humidity display is available as an optional accessory for the AC/DC Low Height Ducted Units. The 3D louvers on the panel offer wide air flow coverage to keep every corners of your room cool or warm in any seasons of the year.

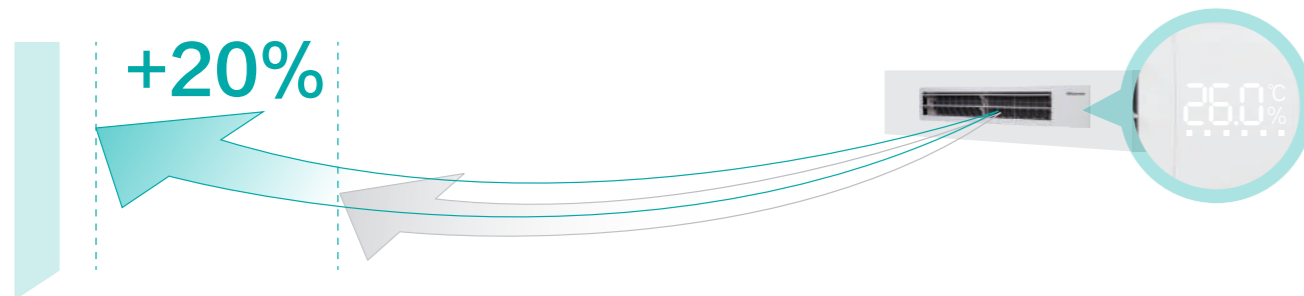
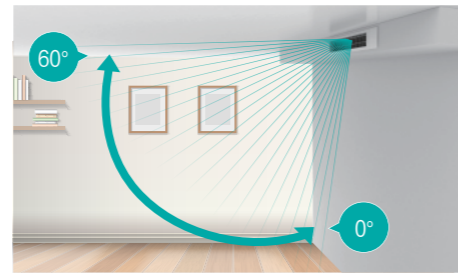

Smart & Precise Temperature Control

To prevent the human height area of the room cools or warms to user's ideal temperature setting. Two Temperature Sensor Control Technology is integrated into the unit whereby the controller, and return section consist of built in temperature sensors to send real-time signals to the unit for a more precise supplying temperature.



Hisense VRF



Conventional

Various Device Connection Options

Third party devices and sensors to control the power supply are possible with dry contact connections to the indoor unit. Devices like hotel room key card, window contact and fire alarms can be connected simultaneously.

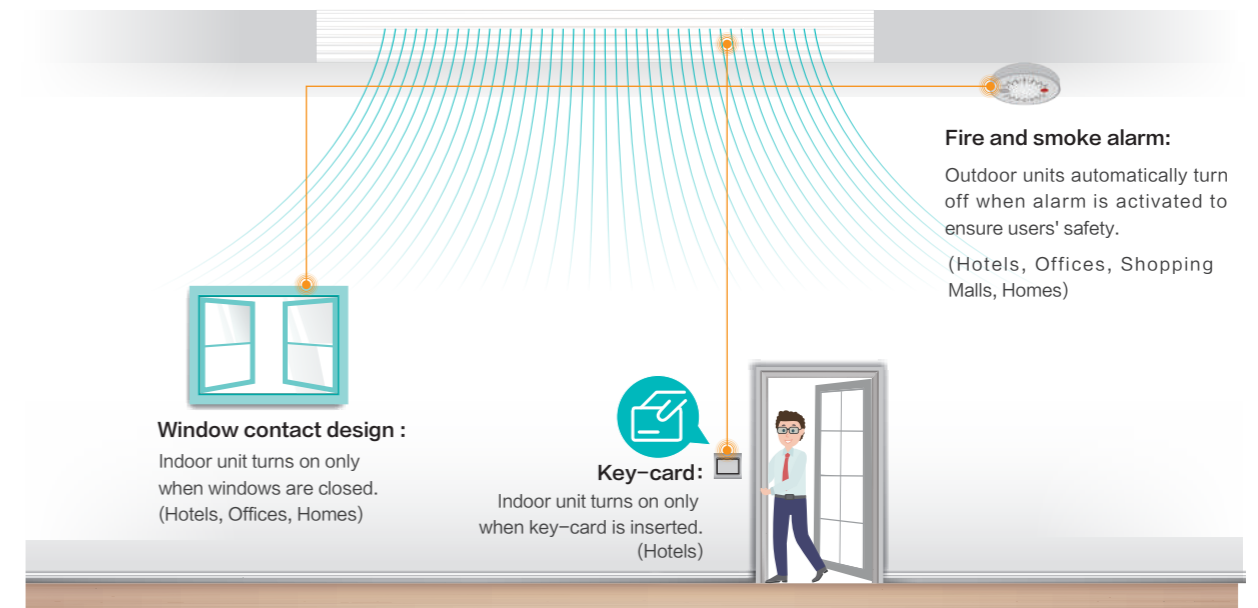

Ceiling Ducted Type (AC Low Height)



Model		AVE-05 HCFRL	AVE-07 HCFRL	AVE-09 HCFRL	AVE-12 HCFRL	AVE-15 HCFRL	AVE-17 HCFRL	AVE-19 HCFRL	AVE-22 HCFRL	AVE-24 HCFRL	
Power Supply		AC 1 φ, 220V~240V/50Hz									
Capacity	Cooling	kW	1.7	2.2	2.8	3.6	4.5	5.0	5.6	6.3	7.1
		Btu/h	5,800	7,500	9,600	12,300	15,300	17,100	19,100	21,500	24,200
	Heating	kW	1.9	2.5	3.2	4.0	5.0	5.6	6.3	7.1	8.0
		Btu/h	6,500	8,500	11,300	13,600	17,100	19,100	21,500	24,200	27,300
Power Input	Cooling	W	50	50	70	70	80	80	100	120	120
	Heating	W	50	50	70	70	80	80	100	120	120
Sound Pressure	dB(A)	29/24/22	29/24/22	35/25/23	35/25/23	36/25/23	36/25/23	35/25/23	39/26/25	39/26/25	
Airflow Rate	m ³ /min	7/5.5/4.7	7/5.5/4.7	9/5.7/4.8	9/5.7/4.8	12/6.3/5.5	12/6.3/5.5	13.5/8/7.7	18/9.3/8.7	18/9.3/8.7	
External Static Pressure	Pa	10(30)	10(30)	10(30)	10(30)	10(30)	10(30)	10(30)	10(30)	10(30)	
Piping	Connection Type	-	Flare-nut Connection (with Flare Nuts)								
	Liquid	mm	φ 6.35	φ 6.35	φ 6.35	φ 6.35	φ 6.35	φ 6.35	φ 6.35	φ 9.53	φ 9.53
		inch	1/4	1/4	1/4	1/4	1/4	1/4	1/4	3/8	3/8
	Gas	mm	φ 12.70	φ 12.70	φ 12.70	φ 12.70	φ 12.70	φ 12.70	φ 15.88	φ 15.88	φ 15.88
		inch	1/2	1/2	1/2	1/2	1/2	1/2	5/8	5/8	5/8
	Condensate Drain	mm	I.D.32								
Weight	Net Weight	kg	16	16	17	17	21	21	25	26	26
	Gross Weight	kg	19	19	20	20	24	24	29	29	29
Dimensions	External	H mm	192	192	192	192	192	192	192	192	192
		W mm	700	700	700	700	910	910	1180	1180	1180
		D mm	447	447	447	447	447	447	447	447	447
		H mm	270	270	270	270	270	270	270	270	270
	Packaging	W mm	925	925	925	925	1136	1136	1406	1406	1406
		D mm	574	574	574	574	574	574	574	574	574

Notes:

1. The nominal cooling capacity and heating capacity are based on the following conditions:
 Cooling Operation Conditions
 Indoor Air Inlet Temperature: 27°C DB (80°F DB), 19.0°C WB (66.2°F WB)
 Outdoor Air Inlet Temperature: 35°C DB (95°F DB)
 Piping Length: 7.5 Meters Piping Lift: 0 Meter
 Heating Operation Conditions
 Indoor Air Inlet Temperature: 20°C DB (68°F DB)
 Outdoor Air Inlet Temperature: 7°C DB (45°F DB), 6°C WB (43°F WB)

2. The sound pressure level is based on the following conditions: 1.5m beneath the unit.
 The above data was measured in an anechoic chamber so that the reflected sound should be taken into consideration in the field.

Ceiling Ducted Type (DC Low Height)



Model		AVE-05 HJFDL	AVE-07 HJFDL	AVE-09 HJFDL	AVE-12 HJFDL	AVE-15 HJFDL	AVE-17 HJFDL	AVE-19 HJFDL	AVE-22 HJFDL	AVE-24 HJFDL	
Power Supply		AC 1 φ, 220V~240V/50Hz/60Hz									
Capacity	Cooling	kW	1.7	2.2	2.8	3.6	4.5	5.0	5.6	6.3	7.1
		Btu/h	5,800	7,500	9,600	12,300	15,300	17,100	19,100	21,500	24,200
	Heating	kW	1.9	2.5	3.2	4.0	5.0	5.6	6.3	7.1	8.0
		Btu/h	6,500	8,500	11,300	13,600	17,100	19,100	21,500	24,200	27,300
Power Input	Cooling	W	30	30	50	50	60	60	60	90	90
	Heating	W	30	30	50	50	60	60	60	90	90
Sound Pressure	dB(A)	28/27/26/ 24/23/21	28/27/26/ 24/23/21	35/32/32/ 30/26/23	35/32/32/ 30/26/23	35/32/32/ 30/26/23	35/32/32/ 30/26/23	35/32/30/ 28/25/23	38/36/35/ 33/31/24	38/36/35/ 33/31/24	
		7.0/6.5/6.1/ 5.7/5.3/4.8	7.0/6.5/6.1/ 5.7/5.3/4.8	9.0/8.1/7.3/ 6.7/5.9/5.2	9.0/8.1/7.3/ 6.7/5.9/5.2	12/10.8/9.4/ 8.1/6.8/5.5	12/10.8/9.4/ 8.1/6.8/5.5	13.5/12.5/11.2/ 10.0/8.8/7.7	18/16.1/14.3/ 12.3/10.5/8.7	18/16.1/14.3/ 12.3/10.5/8.7	
Airflow Rate	m ³ /min	7.0/6.5/6.1/ 5.7/5.3/4.8	7.0/6.5/6.1/ 5.7/5.3/4.8	9.0/8.1/7.3/ 6.7/5.9/5.2	9.0/8.1/7.3/ 6.7/5.9/5.2	12/10.8/9.4/ 8.1/6.8/5.5	12/10.8/9.4/ 8.1/6.8/5.5	13.5/12.5/11.2/ 10.0/8.8/7.7	18/16.1/14.3/ 12.3/10.5/8.7	18/16.1/14.3/ 12.3/10.5/8.7	
External Static Pressure	Pa	10(10/30/50)	10(10/30/50)	10(10/30/50)	10(10/30/50)	10(10/30/50)	10(10/30/50)	10(10/30/50)	10(10/30/50)	10(10/30/50)	
Piping	Connection Type	-	Flare-nut Connection (with Flare Nuts)								
	Liquid	mm	φ 6.35	φ 6.35	φ 6.35	φ 6.35	φ 6.35	φ 6.35	φ 6.35	φ 9.53	φ 9.53
		inch	1/4	1/4	1/4	1/4	1/4	1/4	1/4	3/8	3/8
	Gas	mm	φ 12.70	φ 12.70	φ 12.70	φ 12.70	φ 12.70	φ 12.70	φ 15.88	φ 15.88	φ 15.88
		inch	1/2	1/2	1/2	1/2	1/2	1/2	5/8	5/8	5/8
	Condensate Drain	mm	I.D.32								
Weight	Net Weight	kg	16	16	17	17	20	20	24	24	24
	Gross Weight	kg	19	19	20	20	24	24	29	29	29
Dimensions	External	H mm	192	192	192	192	192	192	192	192	192
		W mm	700	700	700	700	910	910	1180	1180	1180
		D mm	447	447	447	447	447	447	447	447	447
		H mm	270	270	270	270	270	270	270	270	270
	Packaging	W mm	925	925	925	925	1136	1136	1406	1406	1406
		D mm	574	574	574	574	574	574	574	574	574

Notes:

1. The nominal cooling capacity and heating capacity are based on the following conditions:
 Cooling Operation Conditions
 Indoor Air Inlet Temperature: 27°C DB (80°F DB), 19.0°C WB (66.2°F WB)
 Outdoor Air Inlet Temperature: 35°C DB (95°F DB)
 Piping Length: 7.5 Meters Piping Lift: 0 Meter
 Heating Operation Conditions
 Indoor Air Inlet Temperature: 20°C DB (68°F DB)
 Outdoor Air Inlet Temperature: 7°C DB (45°F DB), 6°C WB (43°F WB)

2. The sound pressure level is based on the following conditions: 1.5m beneath the unit.
 The above data was measured in an anechoic chamber so that the reflected sound should be taken into consideration in the field.

Ceiling Ducted Type(DC High Static Pressure)

Auto-adjust External Static Pressure

After installation, the actual duct resistance frequently differ from the initially calculated, causing the actual air flow too low or too high. The auto-adjust ESP function can effectively solve this problem. At the initial commission, the system can automatically select the most appropriate ESP value according to the actual duct resistance.

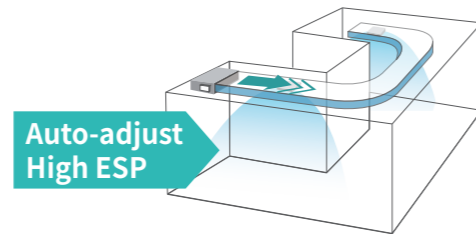
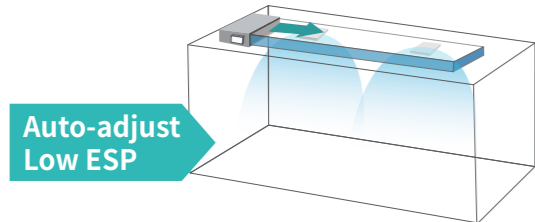

Cold Wind Limit Setting

Thanks to the Cold Wind Limit Setting function, the lowest limit of the outlet air temperature can be set in the range of 10~16°C, which can ensure that the actual outlet temperature will never be lower than the set value, and avoid uncomfortable feeling caused by the direct blowing of cold wind.

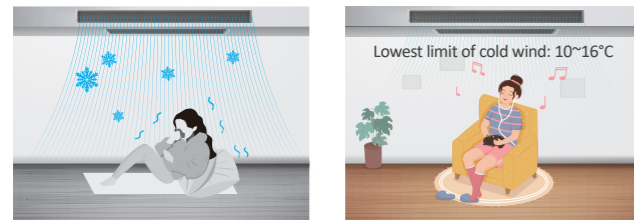

New Improved Bendable Filters

Filters that comes with the units are now optimized to be bendable by improving the material's malleability to improve installation flexibility in narrow ceiling height and restricted spaces.



Self-cleaning Function

Featured with self-cleaning technology, the evaporator can be self-cleaned automatically just with the tap of a button in the controller, which is very convenient and saves the cost of manual cleaning, while ensuring a clean environment.

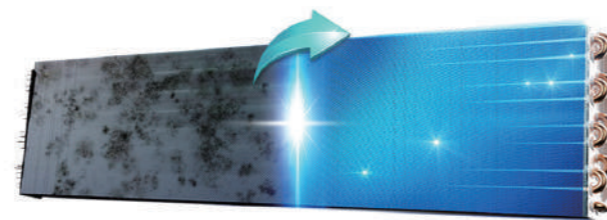

4 processes for deep cleaning

Ceiling Ducted Type (DC High Static Pressure)

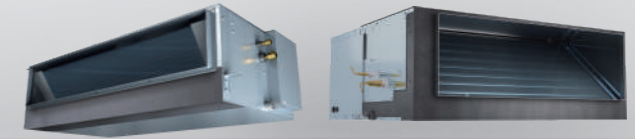

Model		AVD-07	AVD-09	AVD-12	AVD-15	AVD-19	AVD-24	AVD-24	AVD-30	AVD-38	AVD-48	AVD-54	AVD-76	AVD-96		
		HJFH	HJFH	HJFH	HJFH	HJFH	HJFH	HJFH1	HJFH	HJFH	HJFH	HJFH	HJFH	HJFH		
Power Supply		AC 1Φ, 220V-240V/50Hz/60Hz														
Capacity	Cooling	kW	2.2	2.8	3.6	4.5	5.6	7.1	7.1	9.0	11.2	14.0	16.0	22.4	28.0	
		Btu/h	7,500	9,600	12,300	15,400	19,100	24,200	24,200	30,800	38,000	48,000	54,500	76,500	95,600	
Capacity	Heating	kW	2.5	3.2	4.0	4.6	6.3	8.0	8.0	10.0	12.5	16.0	18.0	25.0	31.5	
		Btu/h	8,500	10,900	13,700	17,100	21,600	27,400	27,400	34,200	42,500	54,500	61,500	85,300	107,500	
Power Input	Cooling	W	40	40	55	55	55	82	74	100	132	180	223	610	830	
	Heating	W	40	40	55	55	55	82	74	100	132	180	223	610	830	
Sound Pressure Level	dB(A)	30/27/23/ 21/20/19	30/27/23/ 21/20/19	35/33/32/ 28/26/24	35/33/32/ 28/26/24	33/30/27/ 25/23/22	36/34/31/ 28/24/22	33/31/28/ 25/23/21	34/32/30/ 28/25/22	37/35/31/ 29/26/23	38/36/34/ 31/29/26	41/38/35/ 33/30/27	49/48/47/ 46/45/44	53/52/50/ 49/47/45		
Airflow Rate	m ³ /min	9/8/6.8/ 6.3/5.8/5.3	9/8/6.8/ 6.3/5.8/5.3	12/11/10/ 9/8/7.2	12/11/10/ 9/8/7.2	14.5/13/11.5/ 10.5/9.5/8.7	19/17/15/ 13/11/9.5	20.6/19/17/ 15/13.8/12.5	25/23/21/ 19/17/15	28/25/23/ 21/19/17	35/32.5/29.5/ 26.5/23.5/21.8	39/35.5/31/ 26.5/23.5/21.8	57/54/52/ 51/49/48	72/68/65/ 61/58/50		
External Static Pressure	Pa	30 (30/40/50/60/70/80/90/100/110/120/130/140/150)						50 (50/60/70/80/90/100/110/120/130/140/150/160/170/180/190/200)						150(50-250)	150(50-250)	
Piping	Connection Type	-	Flare-Nut Connection(With Flare Nut)										Brazing			
	Liquid	mm	φ6.35	φ6.35	φ6.35	φ6.35	φ6.35	φ9.53	φ9.53	φ9.53	φ9.53	φ9.53	φ9.53	φ9.53	φ9.53	
		inch	1/4	1/4	1/4	1/4	1/4	3/8	3/8	3/8	3/8	3/8	3/8	3/8	3/8	
	Gas	mm	φ12.7	φ12.7	φ12.7	φ12.7	φ15.88	φ15.88	φ15.88	φ15.88	φ15.88	φ15.88	φ15.88	φ22.2 (φ19.05 ^{*1})	φ22.2	
inch		1/2	1/2	1/2	1/2	5/8	5/8	5/8	5/8	5/8	5/8	5/8	7/8 (3/4 ^{*1})	7/8		
Condensate Drain	-	I.D. 32														
Weight	Net Weight	kg	23	23	24	24	30	30	40	40	40	49	49	104	104	
	Gross Weight	kg	29	29	29	29	37	37	48	48	48	57	57	125	125	
Dimensions	External	H mm	270	270	270	270	270	270	300	300	300	300	300	470	470	
		W mm	650+75	650+75	650+75	650+75	900+75	900+75	1100+75	1100+75	1100+75	1100+75	1400+75	1400+75	1250	1250
		D mm	720	720	720	720	720	720	800	800	800	800	800	1120	1120	
	Packing	H mm	385	385	385	385	385	385	415	415	415	415	415	546	546	
		W mm	895	895	895	895	1140	1140	1345	1345	1345	1345	1640	1640	1466	1466
		D mm	870	870	870	870	870	870	950	950	950	950	950	1345	1345	

Notes:

1. The nominal cooling capacity and heating capacity are based on the following conditions:
 Cooling Operation Conditions
 Indoor Air Inlet Temperature: 27° C DB(80° F DB), 19.0° C WB(66.2° F WB)
 Outdoor Air Inlet Temperature: 35° C DB(95° F DB)
 Heating Operation Conditions
 Indoor Air Inlet Temperature: 20° C DB(68° F DB).
 Outdoor Air Inlet Temperature: 7° C DB(45° F DB), 6° C WB(43° F WB)
 Piping Length: 7.5 Meters Piping Lift: 0 Meter

2. The sound pressure level is based on following conditions.
 1.5m below the unit; With 2.0m discharge duct and 1.0m return duct
 The above data were measured in an anechoic chamber so that reflected sound should be taken into consideration in the field.
 3. *1: The size of AVD-76* series gas pipe is φ22.2mm when leaving the factory, and the diameter can be changed to 19.05mm after welding the adapter pipe.

RELIABILITY EFFICIENCY COMFORT FLEXIBILITY OUTDOOR UNIT INDOOR UNIT CONTROL SYSTEM ACCESSORY

Ceiling Ducted Type (High/Low Static Pressure)

Flexible Air Duct Layout

High static pressure facilitates extensive ducts and air outlets network, effectively sends air-conditioned air to every corner of the room.



New Improved Bendable Filters

Standard filters that comes with high/low static pressure ceiling ducted type are now optimized to be bendable by improving the material's malleability to improve installation flexibility in narrow ceiling height and restricted spaces.



Fresh Air Introducing

There is a fresh air duct opening reserved in the unit for 10% free fresh air introductory directly from outdoor, providing fresh air to the indoor continuously.

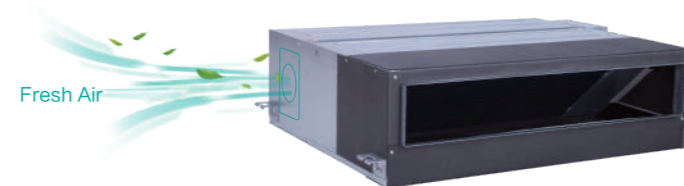

Various Device Connection Options

Third party devices to control the on-off air conditioners is possible with dry contact connections to the Indoor unit. Devices like room key card, window contact and fire alarms can be connected simultaneously.

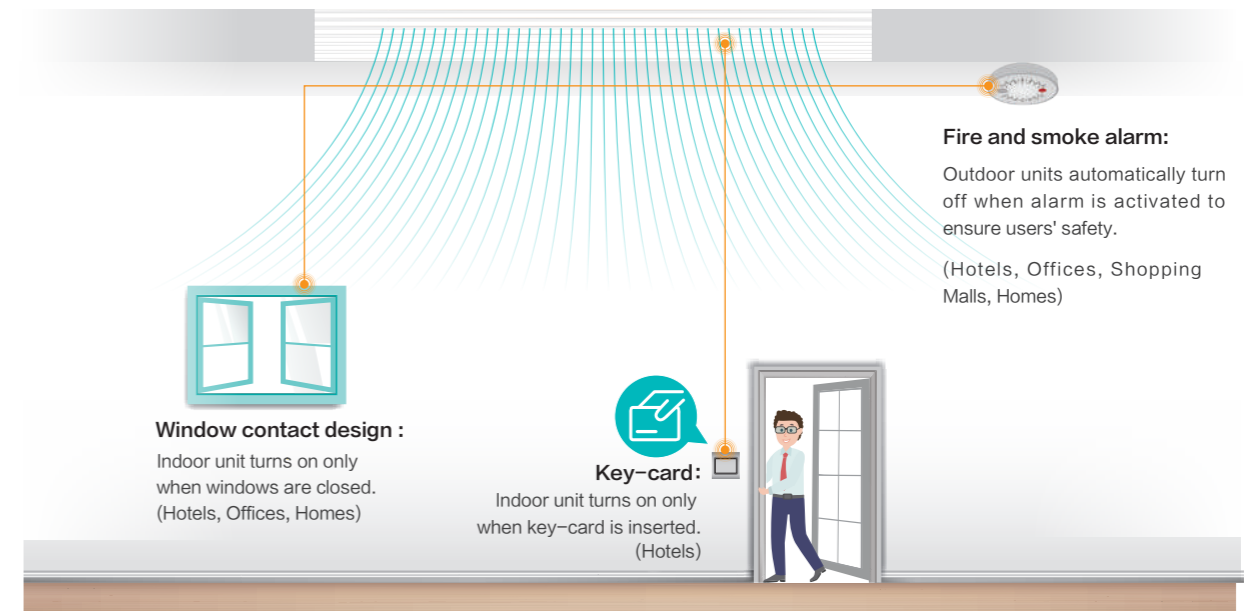

Smart & Precise Temperature Control

To prevent the human height area of the room cools or warms to user's ideal temperature setting. Two Temperature Sensor Control Technology is integrated into the unit whereby the controller, and return section consist of built in temperature sensors to send real-time signals to the unit for a more precise supplying temperature.



Hisense VRF

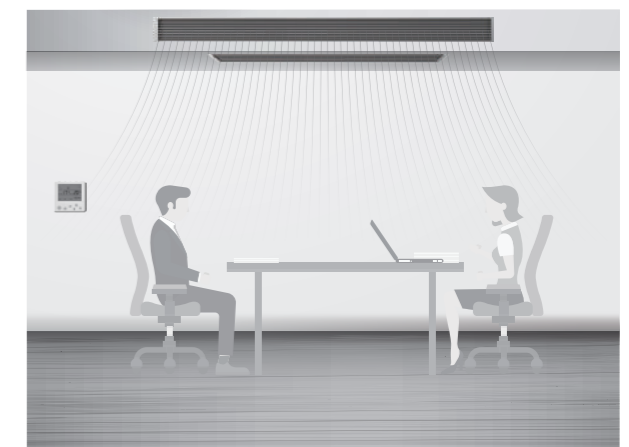

Conventional

Ceiling Ducted Type (High Static Pressure)

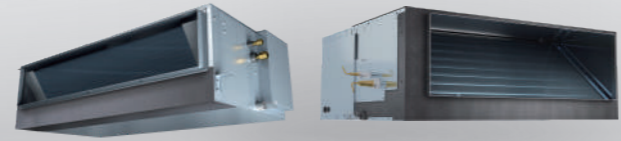

Ceiling Ducted Type (Low Static Pressure)

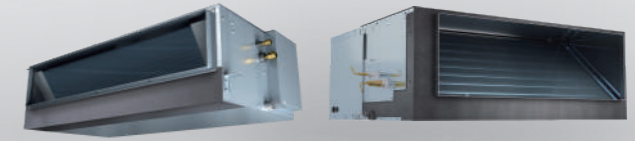

Model	AVD-07 HCFCH	AVD-09 HCFCH	AVD-12H CFCH	AVD-15H CFCH	AVD-19 HCFCH	AVD-22 HCFCH	AVD-24 HCFCH	AVD-27 HCFCH	AVD-30 HCFCH	AVD-38 HCFCH	AVD-48 HCFCH	AVD-54 HCFCH	AVD-76U X6SEH*	AVD-96U X6SFL**		
Power Supply	AC 1 Φ, 220V~240V/50Hz												AC 3 Φ, 380~415V/50Hz			
Model	AVD-07 H3FCH	AVD-09 H3FCH	AVD-12 H3FCH	AVD-15 H3FCH	AVD-19 H3FCH	AVD-22 H3FCH	AVD-24 H3FCH	AVD-27 H3FCH	AVD-30 H3FCH	AVD-38 H3FCH	AVD-48 H3FCH	AVD-54 H3FCH	-	-		
Power Supply	AC 1 Φ, 208~230V/60Hz															
Capacity	Cooling	kW	2.2	2.8	3.6	4.5	5.6	6.3	7.1	8.0	9.0	11.2	14.0	16.0	22.4	28.0
		Btu/h	7,500	9,600	12,300	15,400	19,100	21,600	24,200	27,400	30,800	38,000	48,000	54,500	76,500	95,600
Heating	kW	2.5	3.2	4.0	5.0	6.3	7.1	8.0	9.0	10.0	12.5	16.0	18.0	25.0	31.5	
	Btu/h	8,500	10,900	13,700	17,100	21,600	24,200	27,400	30,800	34,200	42,500	54,500	61,500	85,300	107,500	
Power Input	Cooling	kW	0.10(0.13*)	0.10(0.13*)	0.13(0.16*)	0.13(0.16*)	0.14(0.21*)	0.19(0.24*)	0.19(0.24*)	0.25(0.34*)	0.25(0.34*)	0.25(0.34*)	0.34(0.45*)	0.43(0.59*)	1.08	1.34
	Heating	kW	0.10(0.13*)	0.10(0.13*)	0.13(0.16*)	0.13(0.16*)	0.14(0.21*)	0.19(0.24*)	0.19(0.24*)	0.25(0.34*)	0.25(0.34*)	0.25(0.34*)	0.34(0.45*)	0.43(0.59*)	1.08	1.34
Sound Pressure	220~240V/50Hz	dB(A)	32/27/25	32/27/25	35/32/26	35/32/26	36/35/30	39/32/25	39/32/25	42/39/34	42/39/34	42/39/34	43/40/35	46/40/35	52	54
	208V/60Hz	dB(A)	33/28/24	33/28/24	37/34/29	37/34/29	37/35/29	39/32/25	39/32/25	42/38/33	42/38/33	42/38/33	44/39/34	45/40/34	52	54
	230V/60Hz	dB(A)	37/33/28	37/33/28	40/38/33	40/38/33	42/40/34	43/37/30	43/37/30	44/42/37	44/42/37	44/42/37	47/43/38	46/42/38	52	54
Air Flow(Hi/Me/Lo)	m³/min	9/7/6	9/7/6	12/10/8.5	12/10/8.5	15/13/10	19/14/10	19/14/10	28/24/19.5	28/24/19.5	28/24/19.5	35.5/29/24	39/31/24	58	77.5	
External Static Pressure	220~240V/50Hz 208V/60Hz	Pa	50(80)	50(80)	50(80)	50(80)	50(80)	50(80)	120(90)	120(90)	120(90)	120(90)	120(90)	220	220	
	230V/60Hz	Pa	80(105)	80(105)	90(115)	90(115)	90(115)	90(115)	170(150)	170(150)	170(150)	170(150)	170(150)	-	-	
Piping	Connection Type	-	Flare-nut Connection (with Flare Nuts)										Brazing			
	Liquid	mm	φ 6.35	φ 6.35	φ 6.35	φ 6.35	φ 6.35	φ 9.53	φ 9.53	φ 9.53	φ 9.53	φ 9.53	φ 9.53	φ 9.53	φ 9.53	φ 9.53
		inch	1/4	1/4	1/4	1/4	1/4	3/8	3/8	3/8	3/8	3/8	3/8	3/8	3/8	3/8
	Gas	mm	φ 12.70	φ 12.70	φ 12.70	φ 12.70	φ 15.88	φ 15.88	φ 15.88	φ 15.88	φ 15.88	φ 15.88	φ 15.88	φ 19.05	φ 22.20	
		inch	1/2	1/2	1/2	1/2	5/8	5/8	5/8	5/8	5/8	5/8	5/8	3/4	7/8	
Condensate Drain	mm	I.D.32														
Weight	Net Weight	kg	25(24*)	25(24*)	25(24*)	25(24*)	30(31*)	30(31*)	30(31*)	45(44*)	45(44*)	45(44*)	53(50*)	53(50*)	94	106
	Gross Weight	kg	31(30*)	31(30*)	31(30*)	31(30*)	36(38*)	37(38*)	37(38*)	52(52*)	52(52*)	52(52*)	61(59*)	61(59*)	106	111
Dimensions	External	H mm	270	270	270	270	270	270	300	300	300	300	300	470	470	
		W mm	650+75	650+75	650+75	650+75	900+75	900+75	900+75	1100+75	1100+75	1100+75	1400+75	1400+75	1060	1250
		D mm	720	720	720	720	720	720	800	800	800	800	800	1120	1120	
	Packaging	H mm	385	385	385	385	385	385	415	415	415	415	415	546	546	
		W mm	895	895	895	895	1140	1140	1140	1345	1345	1345	1640	1640	1276	1466
		D mm	870	870	870	870	870	870	870	950	950	950	950	950	1345	1345

Notes:
 1.The nominal cooling capacity and heating capacity are based on the following conditions:
 Cooling Operation Conditions
 Indoor Air Inlet Temperature: 27°C DB (80°F DB), 19.0°C WB (66.2°F WB)
 Outdoor Air Inlet Temperature: 35°C DB (95°F DB)
 Piping Length: 7.5 Meters Piping Lift: 0 Meter
 Heating Operation Conditions
 Indoor Air Inlet Temperature: 20°C DB (68°F DB)
 Outdoor Air Inlet Temperature: 7°C DB (45°F DB), 6°C WB (43°F WB)
 2. The sound pressure level is based on the following conditions: 1.5m beneath the unit.
 With discharge duct (2.0m) and return duct (1.0m).
 The above data was measured in an anechoic chamber so that the reflected sound should be taken into consideration in the field.
 3. When bottom air inlet is adopted, the sound pressure will increase according to factors such as installation mode and the room structure.
 : For AVD-76/96, the filter is not standard.
 **: The value noted ** is the parameter of the indoor units with power supply 208~230V/60Hz.

Model	AVD-07 HCFCL	AVD-09 HCFCL	AVD-12 HCFCL	AVD-15 HCFCL	AVD-19 HCFCL	AVD-22 HCFCL	AVD-24 HCFCL	AVD-27 HCFCL	AVD-30 HCFCL	AVD-38 HCFCL	AVD-48 HCFCL	AVD-54 HCFCL	AVD-76U X6SEL**	AVD-96U X6SFL**		
Power Supply	AC 1 Φ, 220V~240V/50Hz												AC 3 Φ, 380~415V/50Hz			
Capacity	Cooling	kW	2.2	2.8	3.6	4.5	5.6	6.3	7.1	8.0	9.0	11.2	14.0	16.0	22.4	28.0
		Btu/h	7,500	9,600	12,300	15,400	19,100	21,600	24,200	27,400	30,800	38,000	48,000	54,500	76,500	95,600
Heating	kW	2.5	3.2	4.0	5.0	6.3	7.1	8.0	9.0	10.0	12.5	16.0	18.0	25.0	31.5	
	Btu/h	8,500	10,900	13,700	17,100	21,600	24,200	27,400	30,800	34,200	42,500	54,500	61,500	85,300	107,500	
Power Input	Cooling	W	60	60	110	110	90	160	160	240	240	240	290	360	950	1120
	Heating	W	60	60	110	110	90	160	160	240	240	240	290	360	950	1120
Sound Pressure	dB(A)	27/23/21	27/23/21	34/30/25	34/30/25	32/30/26	35/28/24	35/28/24	38/33/30	38/33/30	38/33/30	41/38/33	44/39/33	50	52	
Air Flow Rate (Hi/Me/Lo)	m³/min	9/7/6	9/7/6	12/10/8.5	12/10/8.5	15/13/10	19/14/10	19/14/10	28/24/19.5	28/24/19.5	28/24/19.5	35.5/29/24	39/31/24	58	72	
External Static Pressure	Pa	30	30	30	30	30	30	30	60	60	60	60	60	100	100	
Piping	Connection Type	-	Flare-nut Connection (with Flare Nuts)										Brazing			
	Liquid	mm	φ 6.35	φ 6.35	φ 6.35	φ 6.35	φ 6.35	φ 9.53	φ 9.53	φ 9.53	φ 9.53	φ 9.53	φ 9.53	φ 9.53	φ 9.53	
		inch	1/4	1/4	1/4	1/4	1/4	3/8	3/8	3/8	3/8	3/8	3/8	3/8	3/8	
	Gas	mm	φ 12.70	φ 12.70	φ 12.70	φ 12.70	φ 15.88	φ 15.88	φ 15.88	φ 15.88	φ 15.88	φ 15.88	φ 15.88	φ 19.05	φ 22.20	
		inch	1/2	1/2	1/2	1/2	5/8	5/8	5/8	5/8	5/8	5/8	5/8	3/4	7/8	
Condensate Drain	mm	I.D.32														
Weight	Net Weight	kg	25	25	25	25	30	30	30	45	45	45	52	52	94	106
	Gross Weight	kg	31	31	31	31	36	37	37	52	52	52	61	61	106	111
Dimensions	External	H mm	270	270	270	270	270	270	270	300	300	300	300	470	470	
		W mm	650+75	650+75	650+75	650+75	900+75	900+75	900+75	1100+75	1100+75	1100+75	1400+75	1400+75	1060	1250
		D mm	720	720	720	720	720	720	800	800	800	800	800	1120	1120	
	Packaging	H mm	385	385	385	385	385	385	415	415	415	415	415	546	546	
		W mm	895	895	895	895	1140	1140	1140	1345	1345	1345	1640	1640	1276	1466
		D mm	870	870	870	870	870	870	870	950	950	950	950	950	1345	1345

Notes:
 1.The nominal cooling capacity and heating capacity are based on the following conditions:
 Cooling Operation Conditions
 Indoor Air Inlet Temperature: 27°C DB (80°F DB), 19.0°C WB (66.2°F WB)
 Outdoor Air Inlet Temperature: 35°C DB (95°F DB)
 Piping Length: 7.5 Meters Piping Lift: 0 Meter
 Heating Operation Conditions
 Indoor Air Inlet Temperature: 20°C DB (68°F DB)
 Outdoor Air Inlet Temperature: 7°C DB (45°F DB), 6°C WB (43°F WB)
 2. The sound pressure level is based on the following conditions: 1.5m beneath the unit.
 With discharge duct (2.0m) and return duct (1.0m).
 The above data was measured in an anechoic chamber so that the reflected sound should be taken into consideration in the field.
 3. When bottom air inlet is adopted, the sound pressure will increase according to factors such as installation mode and the room structure.
 : For AVD-76/96, the filter is not standard.

RELIABILITY
 EFFICIENCY
 COMFORT
 FLEXIBILITY
 OUTDOOR UNIT
 INDOOR UNIT
 CONTROL SYSTEM
 ACCESSORY

Wall Mounted Type

High-efficiency DC Fan Motor

The power consumption of the unit with DC fan motor can be reduced greatly in comparison to the old AC product. The minimum power consumption is only 20W, which is reduced by 60%. It can achieve low-cost operation.

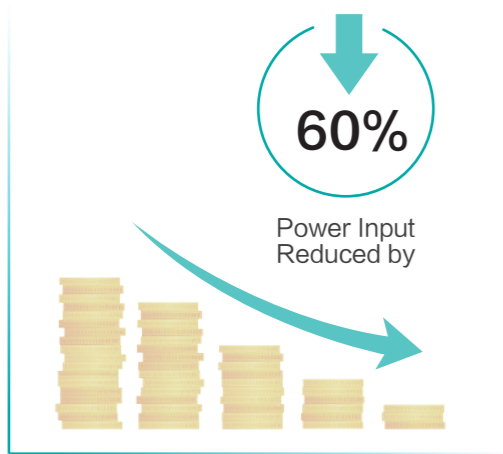

6 Fan Speed

6 indoor fan speeds are available to meet the needs of different indoor conditions.

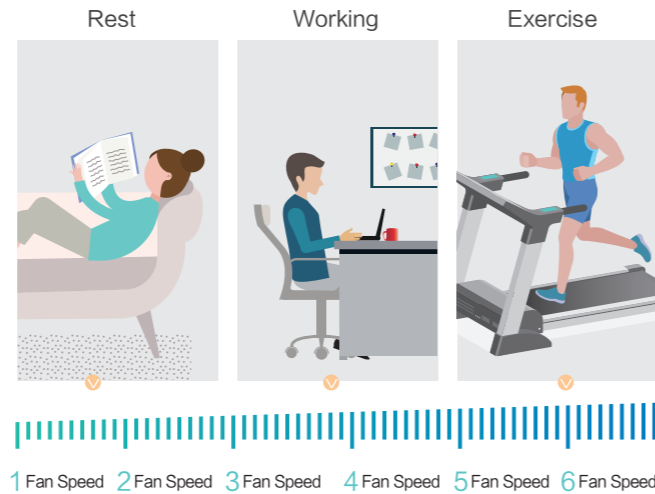

Optimal Noise Control

The low-noise DC fan motor and the enhanced vibration pad on the distribution pipe and EEV will ensure a quieter operation. Besides, with Hisense special smart noise reduction technology, the operation noise can also be decreased effectively. During the high airflow operation, maximum 5dB(A)* is decreased compare with the previous generation. What's more, sleep mode and quiet mode are also available for users to further enjoy a quiet environment.

Take AVS-12 as an example

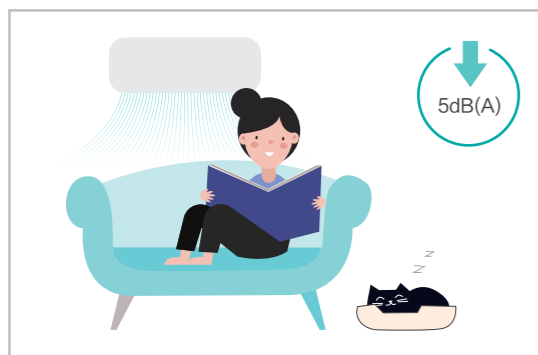

Self-cleaning Function

Featured with self-cleaning technology, the evaporator can be self-cleaned automatically just with the tap of a button in the controller, which is very convenient and saves the cost of manual cleaning, while ensuring a clean environment.

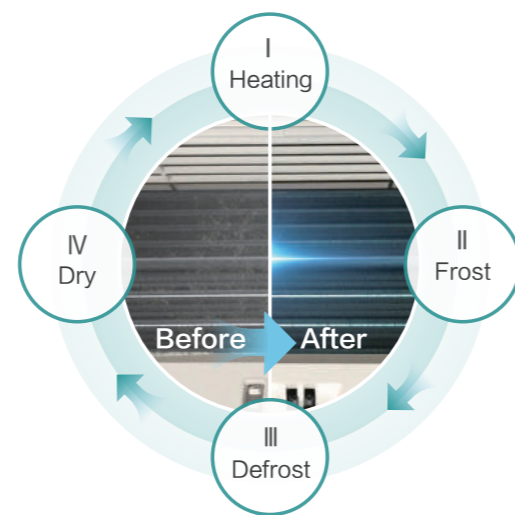

4 processes for deep cleaning



Model		AVS-05 HJFTDD	AVS-07 HJFTDD	AVS-09 HJFTDD	AVS-12 HJFTDD	AVS-15 HJFTDD	AVS-18 HJFTDD	AVS-24 HJFTDD	AVS-28 HJFTDD	
Power Supply		AC 1φ, 220~240V/50Hz; AC 1φ, 220V/60Hz								
Capacity	Cooling	kW	1.7	2.2	2.8	3.6	4.5	5.6	7.1	8.4
		Btu/h	5,800	7,500	9,600	12,300	15,400	19,100	24,200	28,700
	Heating	kW	2.0	2.5	3.3	4.0	5.0	6.3	8.0	8.4
		Btu/h	6,500	8,500	11,300	13,700	17,100	21,500	27,300	28,700
Power Input	Cooling	W	20	20	20	30	20	30	50	80
	Heating	W	20	20	20	30	30	30	70	80
Sound Pressure		dB(A)	33/32/32/ 30/30/28	36/35/33/ 32/30/28	36/35/33/ 32/30/28	38/35/33/ 32/30/28	38/37/36/ 32/31/29	40/38/36/ 35/33/31	45/42/41/ 38/35/31	50/48/45/ 41/36/33
	Airflow Rate	m ³ /min	8.7/8.3/8.2/ 7.5/7.2/7.0	9.8/9.2/8.7/ 8.2/7.5/7.0	9.8/9.2/8.7/ 8.2/7.5/7.0	10.3/9.2/8.7/ 8.2/7.5/7.0	11.5/11.0/10.3/ 9.0/8.7/8.0	16.2/15.0/14.2/ 13.3/12.2/11.5	20.0/18.0/17.0/ 15.0/13.3/11.7	23.3/22.0/20.0/ 17.0/14.2/12.2
Panel Colour		White								
Connection Type		Flare Nuts								
	Liquid	mm	φ6.35	φ6.35	φ6.35	φ6.35	φ6.35	φ9.53	φ9.53	φ9.53
Piping		inch	1/4	1/4	1/4	1/4	1/4	3/8	3/8	3/8
	Gas	mm	φ9.53	φ9.53	φ9.53	φ9.53	φ12.70	φ15.88	φ15.88	φ15.88
		inch	3/8	3/8	3/8	3/8	1/2	5/8	5/8	5/8
Drain Pipe	mm	O.D. 18								
Weight	Net Weight	kg	9.0	9.0	9.0	9.0	13.0	14.5	14.5	14.5
	Gross Weight	kg	12.5	12.5	12.5	12.5	17.0	19.0	19.0	19.0
Dimensions	External	H	mm	270	270	270	270	315	315	315
		W	mm	845	845	845	845	960	1120	1120
	Packaging	D	mm	203	203	203	203	230	230	230
		H	mm	375	375	375	375	430	430	430
	W	mm	943	943	943	943	1058	1223	1223	1223
	D	mm	310	310	310	310	328	328	328	328

Notes:

1. The rated capacity is based on the following conditions:
Cooling conditions: indoor air inlet temperature: 27°C DB, 19°C WB, outdoor air inlet temperature: 35°C DB, pipe length: 7.5m, pipe height difference: 0m.
Heating conditions: indoor air inlet temperature: 20°C DB, outdoor air inlet temperature: 7°C DB, 6°C WB, pipe length: 7.5m, pipe height difference: 0m.

2. The above noise values are measured in an anechoic chamber so that reflected sound should be taken into consideration during actual operation.
The above noise values are measured under the fan mode operation, and measured at a point 1m in front of the unit and 0.8m below the unit.

Ceiling & Floor Type

Sleek Smooth Design

Shiny white cover panel of the unit has a streamlined elegant aesthetic. The bolts and nuts used to secure the unit onto wall or ceiling are designed to be concealed in the unit for a sleek room interior look.



Flexible Installation

The unit can be installed to be standing on floors or hanging on ceilings. Whereby interior walls maximized to display items, can hang the unit on the ceiling.



Hanging on the wall

Standing on the floor

Wide Air Supply

Louvers are consist of horizontal and vertical flaps to cover larger coverage area to the edges of any rooms. Wider opening angle from up to 120° for vertical louvers and up to 71° for horizontal louvers supplies air further and lower down to floor.

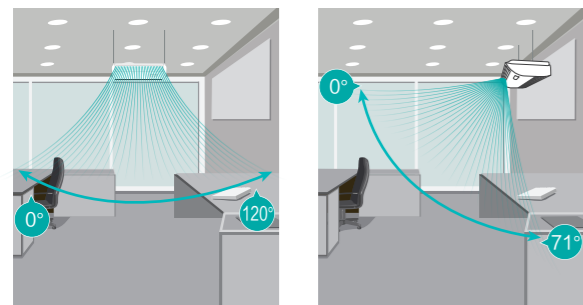

Convenient Installation and Maintenance

Adjust the ceiling or wall mounting height by just opening the side panels without the need to access the internal parts. Service manholes are unnecessary due to the strategic repositioning of piping connections and electrical box behind the air return panel.

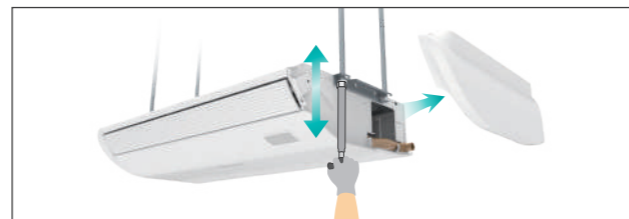

Ceiling & Floor Type



Model		AVV-17URSCA	AVV-18URSCA	AVV-22URSCA	AVV-24URSCA	AVV-27URSCB	AVV-30URSCB	AVV-38URSCB	AVV-48URSCC		
Power Supply		AC 1ϕ, 220V~240V/50Hz/60Hz									
Capacity	Cooling	kW	5.0	5.6	6.3	7.1	8.4	9.0	11.2	14.2	
		Btu/h	17,100	19,100	21,500	24,200	28,700	30,700	38,200	48,500	
	Heating	kW	5.6	6.5	7.5	8.5	9.6	10.0	13.0	16.3	
		Btu/h	19,100	22,200	25,600	29,000	32,800	34,100	44,400	55,600	
Power Input	Cooling	W	40	40	70	70	70	80	130	160	
	Heating	W	40	40	70	70	70	80	130	160	
Sound Pressure	Ceiling	dB(A)	39/35/30	39/35/30	45/41/37	45/41/37	43/39/34	45/40/36	51/46/40	50/46/42	
	Floor	dB(A)	43/38/35	43/38/35	48/44/40	48/44/40	46/41/37	48/43/39	54/49/43	55/50/46	
Airflow Rate	m ³ /min	13.0/11.0/9.0	13.0/11.0/9.0	16.1/14.0/11.3	16.1/14.0/11.3	18.2/15.2/12.2	19.4/16.3/13.3	24.8/20.5/16.3	33.0/28.0/23.0		
Speed-up Setting HH1	m ³ /min	14.2	14.2	17.8	17.8	19.8	21.2	27.0	36.0		
Speed-up Setting HH2	m ³ /min	16.0	16.0	20.0	20.0	22.3	23.5	29.2	37.4		
Panel Colour		Neture White									
Piping	Connection Type		Flare-nut Connection (with Flare Nuts)								
	Liquid	mm	ϕ 6.35	ϕ 6.35	ϕ 9.53	ϕ 9.53	ϕ 9.53	ϕ 9.53	ϕ 9.53	ϕ 9.53	
		inch	1/4	1/4	3/8	3/8	3/8	3/8	3/8	3/8	
	Gas	mm	ϕ 15.88	ϕ 15.88	ϕ 15.88	ϕ 15.88	ϕ 15.88	ϕ 15.88	ϕ 15.88	ϕ 15.88	
inch		5/8	5/8	5/8	5/8	5/8	5/8	5/8	5/8		
Condensate Drain	mm	I.D.32									
Weight	Net Weight	kg	31	31	32	32	39	40	41	47	
	Gross Weight	kg	38	38	39	39	46	47	48	56	
Dimensions	External	H mm	230	230	230	230	230	230	230	230	
		W mm	990	990	990	990	1285	1285	1285	1580	
	Packaging	D mm	680	680	680	680	680	680	680	680	
		H mm	340	340	340	340	340	340	340	340	
	W mm	1110	1110	1110	1110	1400	1400	1400	1690		
	D mm	830	830	830	830	830	830	830	830		

Notes:

1. The nominal cooling capacity and heating capacity are based on the following conditions:
 Cooling Operation Conditions
 Indoor Air Inlet Temperature: 27°C DB (80°F DB), 19.0°C WB (66.2°F WB)
 Outdoor Air Inlet Temperature: 35°C DB (95°F DB)
 Piping Length: 7.5 Meters Piping Lift: 0 Meter
 Heating Operation Conditions
 Indoor Air Inlet Temperature: 20°C DB (68°F DB)
 Outdoor Air Inlet Temperature: 7°C DB (45°F DB), 6°C WB (43°F WB)

2. The sound pressure level is based on the following conditions:
 1.0m beneath the unit, 1.0m from Discharge Grille.
 The above data was measured in an anechoic chamber so that the reflected sound should be taken into consideration in the field. When bottom air inlet is adopted, sound pressure will increase according to factors such as installation mode and the room structure.

Floor Concealed Type

Space Saving

Floor concealed units are designed to be installed on floors completely concealed into the walls which designed to be slim and compact with only height of 620mm to be hidden under half-heighted windows.



Adjustable Static Pressure and Flexible Installation

With 2-level external static pressure adjustable, project design and installation are more flexible. Users can choose the air duct to increase the air supply distance in order to achieve the completely concealed installation.

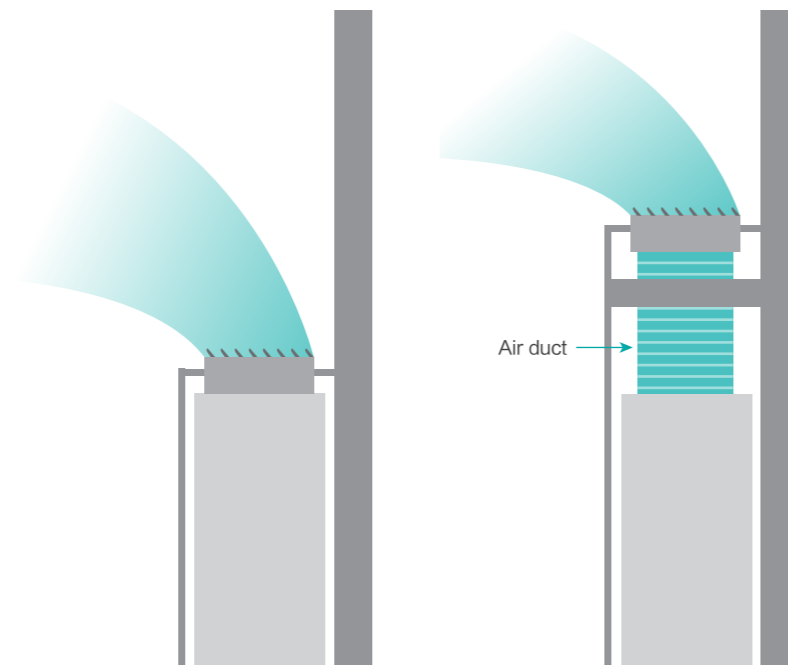

Floor Concealed Type



Model		AVH-09UXCSAA	AVH-14UXCSAA	AVH-18UXCSBA	AVH-24UXCSBA	
Power Supply		AC 1Φ, 220V-240V/50Hz				
Model		AVH-09UX2SAA	AVH-14UX2SAA	AVH-18UX2SBA	AVH-24UX2SBA	
Power Supply		AC 1Φ, 220V/60Hz				
Capacity	Cooling	kW	2.8	4.3	5.6	7.1
		Btu/h	9,600	14,700	19,100	24,200
	Heating	kW	3.3	4.9	6.5	8.5
		Btu/h	11,300	16,700	22,200	29,000
Power Input	Cooling	W	50	80	90	120
	Heating	W	50	80	90	120
Sound Pressure	dB(A)	34/31/27	40/36/34	41/36/32	44/40/36	
Airflow Rate	m ³ /min	8.5/7.5/6.3	10.3/9.0/8.0	14.8/12.3/10.5	16.3/13.8/11.8	
Piping	Connection Type	-	Flare-nut Connection (with Flare Nuts)			
	Liquid	mm	φ 6.35	φ 6.35	φ 6.35	φ 9.53
		inch	1/4	1/4	1/4	3/8
	Gas	mm	φ 12.70	φ 12.70	φ 15.88	φ 15.88
		inch	1/2	1/2	5/8	5/8
	Condensate Drain	mm	I.D.32			
Weight	Net Weight	kg	18	22	26	27
	Gross Weight	kg	30	31	37	37
Dimensions	External	H mm	620	620	620	620
		W mm	948+139	948+139	1218+139	1218+139
		D mm	202	202	202	202
	Packaging	H mm	675	675	675	675
		W mm	1160	1160	1430	1430
		D mm	240	240	240	240

Notes:

1. The nominal cooling capacity and heating capacity are based on the following conditions:
 Cooling Operation Conditions
 Indoor Air Inlet Temperature: 27°C DB (80°F DB), 19.0°C WB (66.2°F WB)
 Outdoor Air Inlet Temperature: 35°C DB (95°F DB)
 Piping Length: 7.5 Meters Piping Lift: 0 Meter
 Heating Operation Conditions
 Indoor Air Inlet Temperature: 20°C DB (68°F DB)
 Outdoor Air Inlet Temperature: 7°C DB (45°F DB), 6°C WB (43°F WB)

2. The sound pressure level is based on the following conditions:
 1.5m meters from the unit and 1.5m meters from floor level.
 The above data was measured in an anechoic chamber so that reflected sound should be taken into consideration in the field.

All Fresh Air Indoor Unit

Space Saving

Fresh air unit consisting of height of 370mm only requires small amount of ceiling space and fits into complicated kitchen ceilings with various exhaust duct connections.

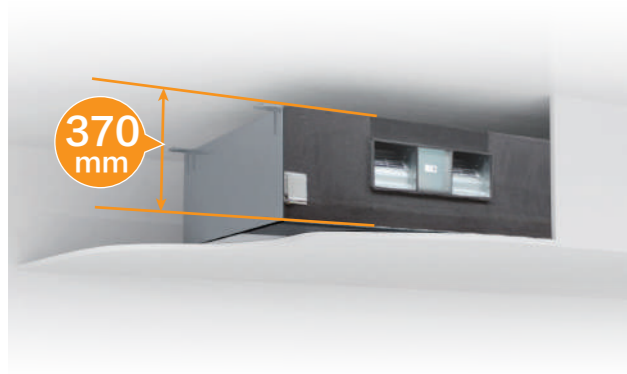

Larger Airflow Rate & Static Pressure Options

The total amount of fresh air units could be reduced with larger capacity, large airflow rate per unit. With the reduced amount of units, fresh air ducts often need to be supply to the furthest room. Hence achievable with high static pressures offered.

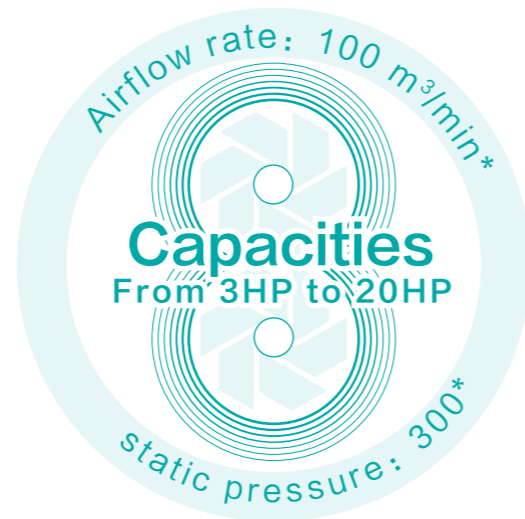

*Note: only specific model can reach this figure.

Simple & Flexible Piping System

Fresh air from the units could be pre-cooled connecting to the same refrigerant systems with other indoor units, introducing cooled or warm fresh air directly without overburdening other fan coil units.



All Fresh Air Indoor Unit



Model	AVA-30UX CSCH-70	AVA-48UX CSQH-108	AVA-76UX CSRH-168	AVA-96UX CSRH-210	AVA-114UX 6SRH-300	AVA-154UX 6SSH-400	AVA-190UX 6STH-500	AVA-190UX 6STH-600			
Power Supply	AC 1ϕ, 220V-240V/50Hz				AC 3ϕ, 380V-415V/50Hz						
Model	AVA-30UX 2SCH-70	AVA-48UX 2SQH-108	AVA-76UX 2SRH-168	AVA-96UX 2SRH-210	-						
Power Supply	AC 1ϕ, 220V/60Hz				-						
Capacity	Cooling	kW	9.0	14.0	22.4	28.0	33.5	45.0	56.0	56.0	
		Btu/h	30,700	47,800	76,500	95,600	114,300	153,600	191,100	191,100	
Capacity	Heating	kW	8.6	13.7	21.9	24.5	26.8	36.0	44.8	44.8	
		Btu/h	29,400	46,800	74,700	83,600	91,500	122,900	152,900	152,900	
Power Input	Cooling	W	150	330	490	510	740	1120	1330	1620	
	Heating	W	150	330	490	510	740	1120	1330	1620	
Sound Pressure		dB(A)	32	43	45	46	56	61	64	66	
Airflow Rate		m ³ /min	11.0	18.0	28.0	35.0	50.0	66.7	83.3	100.0	
External Static Pressure		Pa	60(120)	200	220	220	220	300	320	300	
Piping	Liquid	mm	ϕ 9.53	ϕ 9.53	ϕ 9.53	ϕ 9.53	ϕ 12.70	ϕ 12.70	ϕ 15.88	ϕ 15.88	
		inch	3/8	3/8	3/8	3/8	1/2	1/2	5/8	5/8	
Piping	Gas	mm	ϕ 15.88	ϕ 15.88	ϕ 19.05	ϕ 22.20	ϕ 25.40	ϕ 25.40	ϕ 28.60	ϕ 28.60	
		inch	5/8	5/8	3/4	7/8	1	1	1-1/8	1-1/8	
	Condensate Drain	mm	I.D.32				RC1 (Internal Screw)				
Weight	Net Weight	kg	46	60	97	97	97	196	222	222	
	Gross Weight	kg	51	64	117	117	117	240	267	267	
Dimensions	External	H	mm	370	370	486	486	486	635	735	735
		W	mm	920	1320	1270	1270	1270	1950	1950	1950
		D	mm	800	800	1069	1069	1069	805	805	805
	Packaging	H	mm	390	390	540	540	540	816	916	916
		W	mm	1112	1512	1466	1466	1466	2213	2213	2213
		D	mm	922	922	1290	1290	1290	1006	1006	1006
Temperature Range of Fresh Air		-	Cooling: 20°C-43°C, Heating: -5°C-15°C								

Notes:

- The nominal cooling capacity and heating capacity are based on following conditions:
Cooling operation conditions: 33°C DB, 28°C WB, piping length: 7.5m, piping lift: 0m.
Heating operation conditions: 0°C DB, -2.9°C WB, piping length: 7.5m, piping lift: 0m.
(Heating capacity is tested when defrosting is not available)
- The sound pressure level is based on following conditions: 1.5m beneath the unit.
The above data was measured in an anechoic chamber so that reflected sound should be taken into consideration in the field.
- The unit shall be connected to the outdoor unit. In case of connecting the fresh air indoor unit with other types of indoor units in the same refrigerant system, please calculate the capacity of the unit as 46.1kBTu/h (30.7kBTu/h), 71.7kBTu/h (47.8kBTu/h), 143.3kBTu/h (95.6kBTu/h).
- When the outdoor unit is connected only with all fresh air indoor unit, the configuration rate is 100%.
- Under cooling mode, when outdoor temperature is lower than 20°C, the system will automatically shift to ventilation operation;
Under heating mode, when outdoor temperature is higher than 15°C the system will automatically shift to ventilation operation;
In case inlet temperature is below -5°C, all fresh air unit will stop.

RELIABILITY
EFFICIENCY
COMFORT
FLEXIBILITY
OUTDOOR UNIT
INDOOR UNIT
CONTROL SYSTEM
ACCESSORY

Heat Recovery Ventilator

Compact Machine, Convenient Installation

The thickness of machine can be easily installed in the narrow residential ceiling. The width of the machine whose air flow rate is under 300m³/h is less than 600mm, which is particularly suitable for very narrow spaces in the ceiling, and can save the space of installation, it is more convenient for construction.

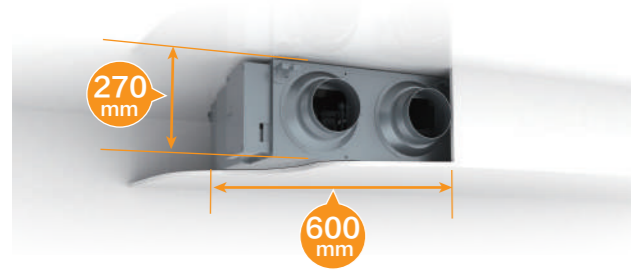

Airflow System

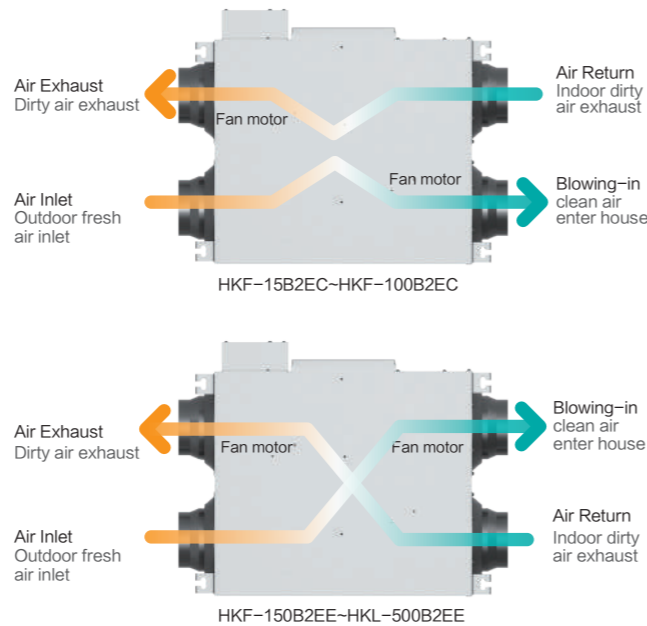

Energy Saving Analysis

Summer Energy Saving Analysis

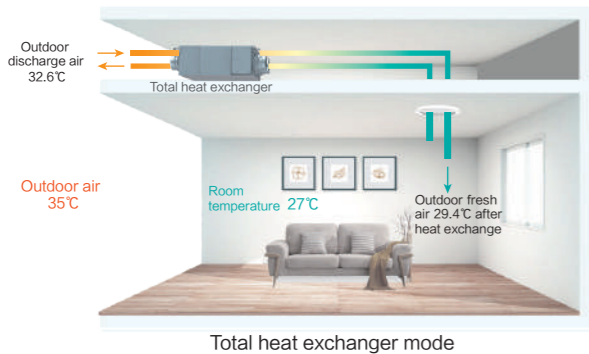

In summer operation, when the cold energy of 27°C air discharged from indoor pass through the heat exchanger, the 35°C outdoor hot air is pre-cooled to 29.4°C fresh air and supplied to indoors, as shown above, the air conditioner only needs to cool the air by 2.4°C to maintain a comfortable room temperature and fresh air. In this process, the discharge air pre-cools the fresh air by HRV, The temperature recovery efficiency in cooling is 70% max, and enthalpy exchange efficiency is 57% max.

Winter Energy Saving Analysis

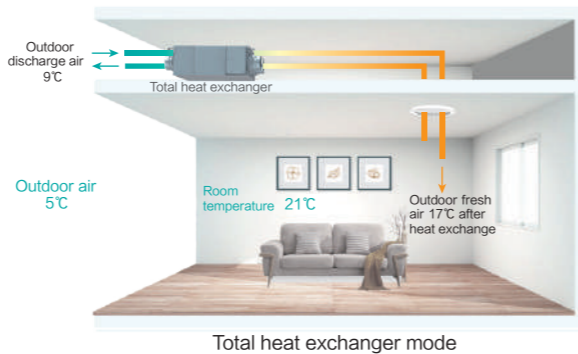

In winter operation, when the heat energy of 21°C air discharged from indoor pass through the heat exchanger, the 5°C outdoor cold air is pre-heated to 17°C fresh air and supplied to indoors, as shown above, when outdoor 5°C air and indoor 21°C air pass through the HRV, the fresh air supplied to indoors is about 17°C, the air conditioner only needs to heat the air by 4°C to maintain a comfortable room temperature and fresh air. The temperature recovery efficiency in heating is 75% max, and enthalpy exchange efficiency is 63% max.

Heat Recovery Ventilator

Centralized Control System

Hisense heat recovery ventilator can be connected to the Hisense VRF Central Control System, achieving the central control from Hisense VRF controllers. The operation is more convenient and more intelligent.

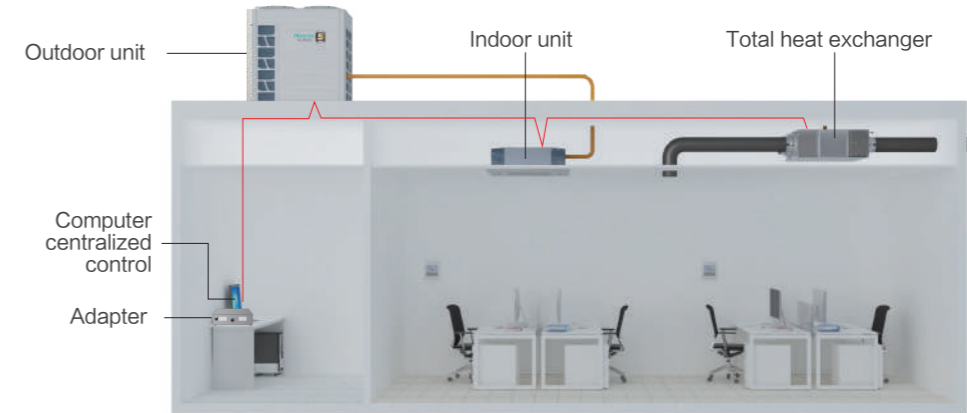

HKF-15B2EC

Product Dimensions

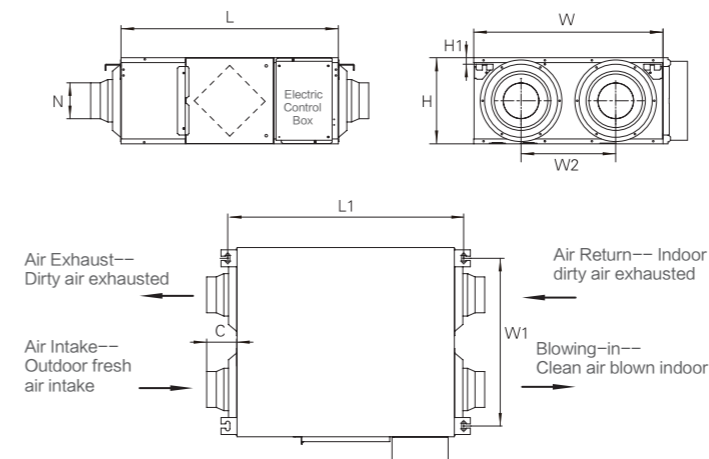

Model	L	L1	W	W1	W2	H	C	N	H1
HKF-15B2EC*	665	723	580	514	290	265	90	φ144	20

Technical Parameters

Model	Air Volume m ³ /h			Enthalpy Efficiency (Summer) η _i			Enthalpy Efficiency (Winter) η _i			External Static Pressure Pa			Power Supply	Input Current A			Input Power kW			Noise Level dB(A)			Weight kg
	High	Middle	Low	High	Middle	Low	High	Middle	Low	High	Middle	Low		High	Middle	Low	High	Middle	Low				
HKF-15B2EC*	150	150	110	58	58	60	65	65	69	85	70	65	220-240V/50HZ	0.38	0.36	0.31	2 × 0.041	2 × 0.038	2 × 0.029	30	29	28	25

*: 220V/60Hz HKF-15B2E2

HKF-25B2EC~HKF-100B2EC

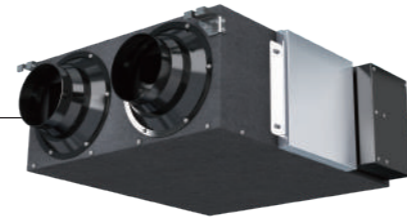

Product Dimensions

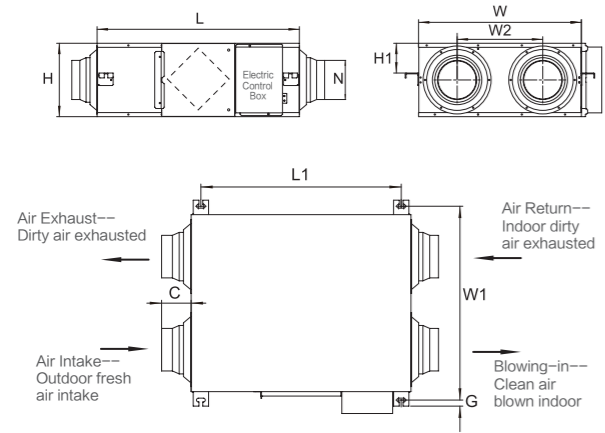

Model	L	L1	W	W1	W2	H	C	G	N	H1
HKF-25B2EC*	745	675	600	656	315	270	90	19	φ144	110
HKF-35B2EC*	745	675	805	861	480	270	90	19	φ144	110
HKF-50B2EC*	825	755	905	961	500	270	96	19	φ194	110
HKF-65B2EC*	1115	1050	885	941	430	390	80	19	φ242	175
HKF-80B2EC*	1115	1050	1135	1191	675	390	80	19	φ242	175
HKF-100B2EC*	1115	1050	1135	1191	675	390	80	19	φ242	175

Technical Parameters

Model	Air Volume m ³ /h			Enthalpy Efficiency (Summer) η _i			Enthalpy Efficiency (Winter) η _i			External Static Pressure Pa			Power Supply	Input Current A			Input Power kW			Noise Level dB(A)			Weight kg
	High	Middle	Low	High	Middle	Low	High	Middle	Low	High	Middle	Low		High	Middle	Low	High	Middle	Low	High	Middle	Low	
HKF-25B2EC*	250	250	190	57	57	59	63	63	68	85	65	60	220-240V 50Hz	0.66	0.56	0.52	2×0.069	2×0.055	2×0.049	32	31	28	30
HKF-35B2EC*	350	350	270	55	55	57	62	62	65	100	75	65		0.76	0.75	0.71	2×0.083	2×0.079	2×0.075	34	33	31	35
HKF-50B2EC*	500	500	400	56	56	58	63	63	65	130	110	100		1.82	1.71	1.52	2×0.189	2×0.157	2×0.124	39	38	36	40
HKF-65B2EC*	650	650	550	57	57	59	63	63	68	130	100	100		1.75	1.62	1.51	2×0.193	2×0.178	2×0.164	40	38	35	62
HKF-80B2EC*	800	800	650	58	58	59	66	66	68	130	100	90		1.98	1.88	1.75	2×0.211	2×0.196	2×0.18	42	40	37	72
HKF-100B2EC*	1000	1000	700	56	56	58	63	63	66	165	120	60		4.68	4.18	3.47	2×0.510	2×0.450	2×0.363	44	42	38	79

*: AC 1Φ, 220V/60Hz HKF-25B2E2~HKF-100B2E2

HKF-150B2EE~HKF-200B2EE



Product Dimensions

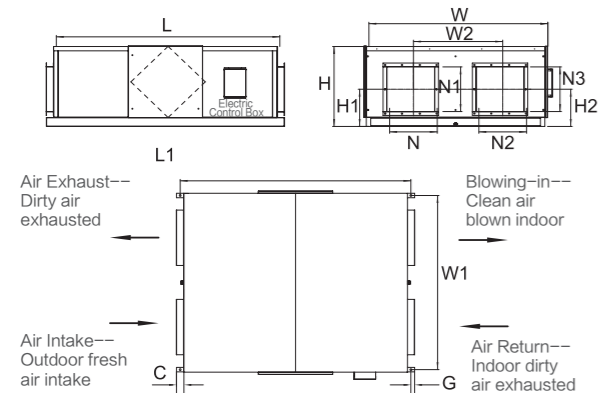

Model	L	L1	W	W1	W2	H	H1
HKF-150B2EE*	1500	1550	1200	1170	600	540	250
HKF-200B2EE*	1550	1600	1400	1370	700	540	250

Model	C	G	N	N1	N2	N3	H2
HKF-150B2EE*	50	25	320	300	320	300	250
HKF-200B2EE*	50	25	320	300	320	300	250

Technical Parameters

Model	Air Volume m ³ /h	Enthalpy Efficiency (Summer) η _i	Enthalpy Efficiency (Winter) η _i	External Static Pressure Pa	Power Supply	Input Current A	Input Power kW	Noise Level dB(A)	Weight kg
HKF-150B2EE*	1500	55	63	180	380-415V/50Hz	2.78	2×0.41	48	151
HKF-200B2EE*	2000	54	62	160	380-415V/50Hz	2.89	2×0.52	49	172

*: AC 3Φ, 220V/60Hz HKF-150B2E9 HKF-200B2E9

AC 3Φ, 380V/60Hz HKF-150B2EF HKF-200B2EF

HKF-250B2EE~HKF-300B2EE



Product Dimensions

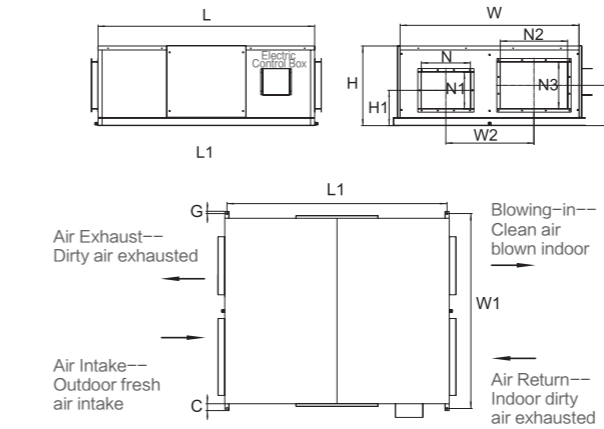

Model	L	L1	W	W1	W2	H	H1
HKF-250B2EE*	1610	1580	1330	1400	655	600	265
HKF-300B2EE*	1700	1670	1500	1570	750	640	272

Model	C	G	N	N1	N2	N3	H2
HKF-250B2EE*	50	15	365	275	500	350	300
HKF-300B2EE*	50	15	365	275	500	350	309

Technical Parameters

Model	Air Volume m ³ /h	Enthalpy Efficiency (Summer) η _i	Enthalpy Efficiency (Winter) η _i	External Static Pressure Pa	Power Supply	Input Current A	Input Power kW	Noise Level dB(A)	Weight kg
HKF-250B2EE*	2500	54	62	180	380-415V/50Hz	3.86	2×0.72	53	185
HKF-300B2EE*	3000	55	63	200	380-415V/50Hz	5.12	2×1.16	56	222

*: AC 3Φ, 220V/60Hz HKF-250B2E9 HKF-300B2E9 AC 3Φ, 380V/60Hz HKF-250B2EF HKF-300B2EF

HKL-400B2EE~HKL-500B2EE



Product Dimensions

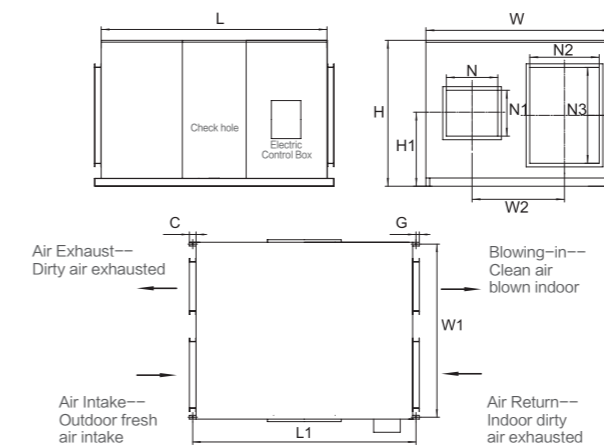

Model	L	L1	W	W1	W2	H	H1
HKL-400B2EE*	1625	1675	1330	1300	665	1050	490
HKL-500B2EE*	1625	1675	1330	1300	665	1050	490

Model	C	G	N	N1	N2	N3	H2
HKL-400B2EE*	50	25	370	330	500	690	475
HKL-500B2EE*	50	25	370	330	500	690	475

Technical Parameters

Model	Air Volume m ³ /h	Enthalpy Efficiency (Summer) η _i	Enthalpy Efficiency (Winter) η _i	External Static Pressure Pa	Power Supply	Input Current A	Input Power kW	Noise Level dB(A)	Weight kg
HKL-400B2EE*	4000	55	63	220	380-415V/50Hz	5.89	2×1.71	57	312
HKL-500B2EE*	5000	53	61	240	380-415V/50Hz	8.78	2×2.2	58	321

*: AC 3Φ, 220V/60Hz HKL-400B2E9 HKL-500B2E9 AC 3Φ, 380V/60Hz HKL-400B2EF HKL-500B2EF

RELIABILITY

EFFICIENCY

COMFORT

FLEXIBILITY

OUTDOOR UNIT

INDOOR UNIT

CONTROL SYSTEM

ACCESSORY

AHU Connection KIT

Main Function

- ON/OFF Control
- Temperature Setting
- Capacity Demand
- Operation Mode

— Communication wire — Sensor signal — Refrigerant pipe

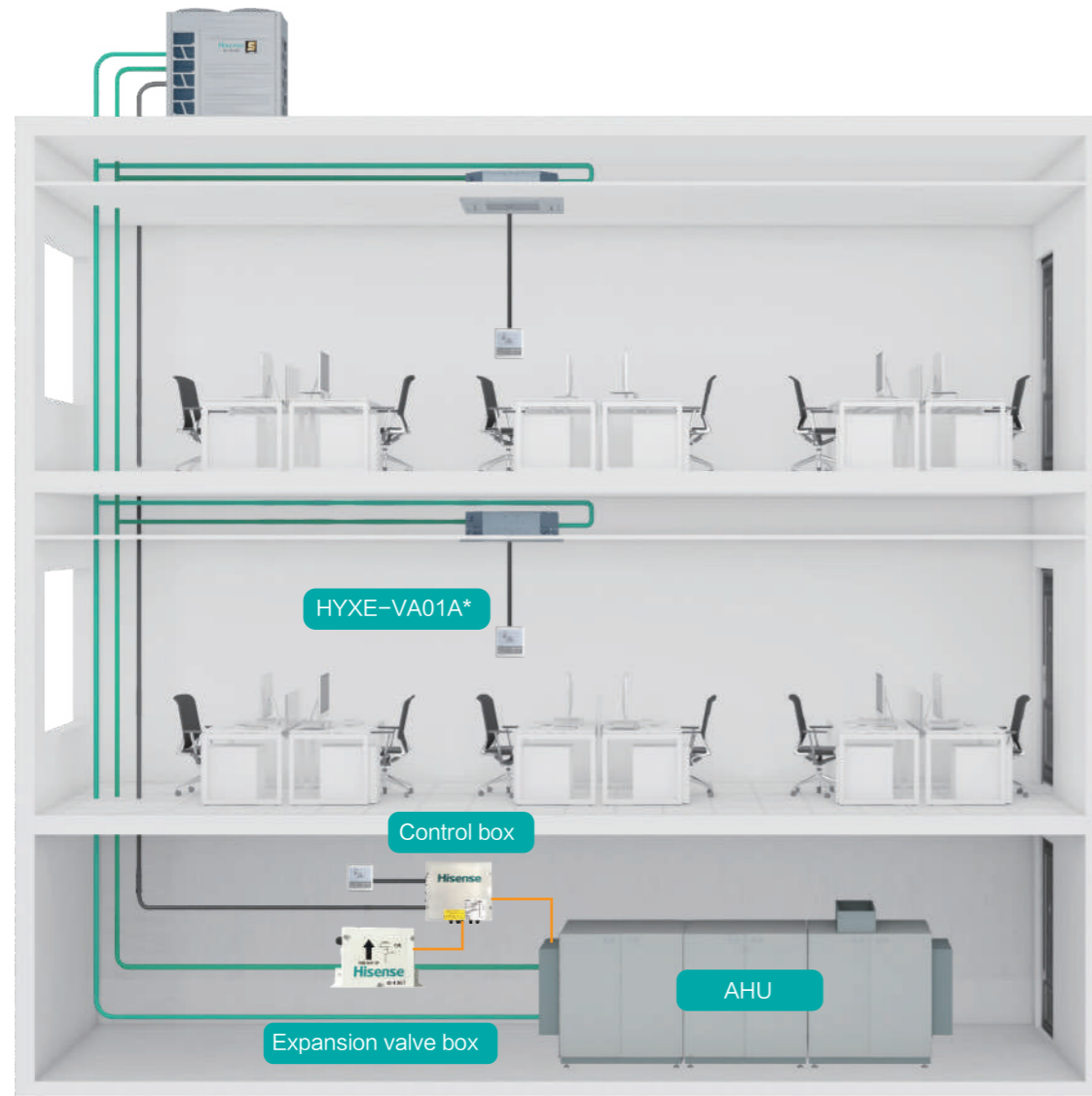

*The wired controller HYXE-VA01A is standard.

AHU Connection KIT

AHU kit can provide 3 kinds of control type for AHU application: Inlet air temperature control, outlet air temperature control and duty signal control.

Capacity Control Mode	Set Temperature by Remote Controller	Set ODU Capacity Range
Inlet Air (room air) Temperature Control	Cooling: 19~30 °C Heating: 17~30 °C	—
Outlet Air Temperature Control		
Duty Signal Control (0~10V or 0~5V or 4~20mA)	—	15%~100%

AHU Connection KIT		HZX-2.0 AEC	HZX-4.0 AEC	HZX-6.0 AEC	HZX-10.0 AEC	HZX-20.0 AEC					HZX-30.0 AEC						
Power Supply		AC 1 φ, 220V~240V/50Hz, 220V~240V/60Hz															
Nominal Capacity of AHU	HP	2	4	6	8	10	12	14	16	18	20	22	24	26	28	30	
Allowed Heat Exchanger Capacity (H/M/L)	Cooling	kW	4.0	7.1	11.2	16.0	20.0	28.0	33.5	40.0	45.0	50.0	56.0	61.5	69.0	73.0	80.0
		kW	5.0	9.0	14.0	20.0	25.0	30.0	35.0	43.0	48.0	52.0	58.0	65.0	71.0	76.0	82.0
		kW	5.6	11.2	16.0	22.4	28.0	33.5	40.0	45.0	50.0	56.0	61.5	69.0	73.0	80.0	85.0
	Heating	kW	4.5	8.0	12.5	17.9	22.4	31.5	37.5	45.0	50.0	56.0	63.0	69.0	77.5	82.5	90.0
		kW	5.6	10.0	16.0	22.4	28.0	33.5	40.0	47.5	53.0	60.0	66.0	75.0	79.0	86.0	92.0
		kW	7.1	12.5	18.0	25.0	31.5	37.5	45.0	50.0	56.0	63.0	69.0	77.5	82.5	90.0	95.0
Heat Exchanger Volume	Min	dm ³	0.57	1.03	1.92	2.92	3.89	4.76	5.85	6.79	7.57	8.47	9.04	9.50	10.39	11.39	12.36
	Max	dm ³	1.16	2.37	2.92	3.89	4.76	5.91	6.89	8.00	8.92	9.97	11.13	12.34	12.89	13.86	14.73
Equivalent Indoor Unit Capacity	HP	2	4	6	8	10	12	14	16	18	20	22	24	26	28	30	
Net Weight	kg	7.3	7.3			7.5					9.5						
Gross Weight	kg	12.3	12.4			12.5					16.0						
Package Dimension (H × W × D)	mm	350 × 510 × 450										460 × 510 × 450					
Control Box	Model	HZX-AEC/1															
	Outer Dimension(H × W × D)	349 × 419 × 112															
Expansion Valve Box	Model	HZX-2.0 AEC/2	HZX-4.0 AEC/2	HZX-6.0 AEC/2	HZX-10.0 AEC/2	HZX-20.0 AEC/2					HZX-30.0 AEC/2 (2 sets)						
	Outer Dimension(H × W × D)	166 × 437 × 61										166 × 437 × 61 (2 sets)					

Operation conditions		Cooling	Heating
Indoor air inlet temperature	DB	27.0°C	20.0°C
	WB	19.0°C	—
Outdoor air inlet temperature	DB	35.0°C	7.0°C
	WB	—	6.0°C

DB: dry bulb; WB: wet bulb
Pipe Length: 7.5m; pipe height: 0m

CONTROL SYSTEM



Individual Control

Centralized Control

Intelligent Control

AIR
CONDITIONING
SOLUTION

Individual Control

Model	Wired Controller					Wireless Controller	Central Controller	
	HYXM-VB01A	HYXE-VC01	HYXE-J01H	HYXE-VA01A	HYXE-S01H	HYE-VD01	HYJ-J01H	HYJM-S01H
Picture								
Max. connectable indoor units	6	6	16	16	16	-	128	160
Cooling/Heating/Auto	●	●	●	●	●	●	×	●
Dehumidification	●	●	●	●	●	×	×	●
Fan speed	●	●	●	●	●	●	×	●
Louver setting	●	●	●	●	●	●	×	●
Temperature setting	●	●	●	●	●	●	×	●
Operation monitoring	●	●	●	●	●	●	×	●
24-hour timer	●	●	●	●	●	●	×	●
7-day timer	●	×	●	×	×	×	×	●
Holiday setting	●	×	●	×	×	×	×	●
Main-sub control	●	●	●	●	×	×	×	×
Check function	●	●	●	●	●	×	×	×
Air filter cleaning reminding	●	●	●	●	●	×	×	●
Error code history display	●	●	●	●	●	×	×	●
Auto test run	●	●	●	●	●	●	×	×
Indoor/Outdoor PCB checking	●	●	●	●	●	×	×	×
Self diagnostic function	●	●	●	●	●	●	●	●
Back light	●	●	●	●	●	●	×	●
Built-in temperature sensor	×	●	●	●	×	●	×	×
Wireless control available	●	●	×	×	×	×	×	×
Individual louver control	●	●	●	●	×	●	×	×
Breeze mode	●	●	●	●	×	●	×	×
Motion sensor	●	×	●	●	×	×	×	×
Health (AirPure)	●	●	●	●	×	●	×	×
Hi-Motion	●	×	●	×	×	×	×	×
ECO (energy saving)	●	●	●	●	×	●	×	●
Quiet	●	●	●	●	●	●	×	×
Sleep	●	●	●	●	×	●	×	×
Window contact design	●	●	●	●	×	×	×	×
3D-air flow	●	●	●	●	×	●	×	×
Self-cleaning	●	●	×	●	×	●	×	×

Remarks: Available: ● Unavailable: ×

RELIABILITY

EFFICIENCY

COMFORT







FLEXIBILITY

OUTDOOR UNIT

INDOOR UNIT

CONTROL SYSTEM

ACCESSORY

Type	Wired Controller					Wireless Controller
Model	HYXM-VB01A	HYXE-VC01	HYXE-J01H	HYXE-VA01A	HYXE-S01H	HYE-VD01
Picture						
4-Way Cassette	○	○	○	○	○	○
Mini 4-Way Cassette	○	○	○	○	○	○
1-Way Cassette	○	○	○	○	×	○
2-Way Cassette	○	○	○	○	×	○
Indoor Unit						
Ceiling Ducted Type (AC/DC)	○	○	○	○	○	○
Ceiling Ducted Type (High/Low)	○	○	○	○	○	○
Console	○	○	○	○	○	●
Wall Mounted Type	○	○	○	○	○	●
Ceiling & Floor Type	○	○	○	○	○	●
Floor Concealed Type	○	○	○	○	×	○
All Fresh Air	○	○	○	○	○	○
Heat Recovery Ventilator	○	●	○	○	○	×
AHU Kit	○	○	○	●	×	×

Type	Receiver Kit				Centralized Controller	ON/OFF
Model	HYRE-V02H	HYRE-Z01H	HYRE-T03H	HYRE-X01H	HYJM-S01H	HYJ-J01H
Picture						
4-Way Cassette	×	×	○	×	○	○
Mini 4-Way Cassette	×	○	×	×	○	○
1-Way Cassette	×	×	×	○	○	○
2-Way Cassette	○	×	×	×	○	○
Indoor Unit						
Ceiling Ducted Type (AC/DC)	○	×	×	×	○	○
Ceiling Ducted Type (High/Low)	○	×	×	×	○	○
Console	○	×	×	×	○	○
Wall Mounted Type	○	×	×	×	○	○
Ceiling & Floor Type	○	×	×	×	○	○
Floor Concealed Type	○	×	×	×	○	○
All Fresh Air	○	×	×	×	○	○
Heat Recovery Ventilator	×	×	×	×	○	○

Remarks: Standard: ● Optional: ○ Incompatible: ×

Wired Controller

HYXM-VB01A



Mode	Cool/Heat/Auto/Fan/Dry
Timer	24-hour/Weekly schedule/Holiday setting
Maintenance	Error code/Parameter check/Auto test run/ Indoor&Outdoor PCB checking/Self diagnostic function
Louver	Louver setting/Individual louver control/ 3D-air flow
Special function	Breeze mode/Motion sensor/Health/ Hi-Motion/ECO/Quiet/Sleep/Self-cleaning
Fan speed	6
Temperature setting	0.5°C
Main-sub control	•
Air filter cleaning reminding	•
Back light	•
Wireless control available	•

Features

- Size: 86mm × 90mm
- Max. connectable indoor units: 6
- LCD display
- Touch screen
- Language:
VB01A: English, Turkish, Russian,
German, Arabic, spanish
VB01A#01: English, French, Italian,
Dutch, Polish, Thai

Colorful Screen

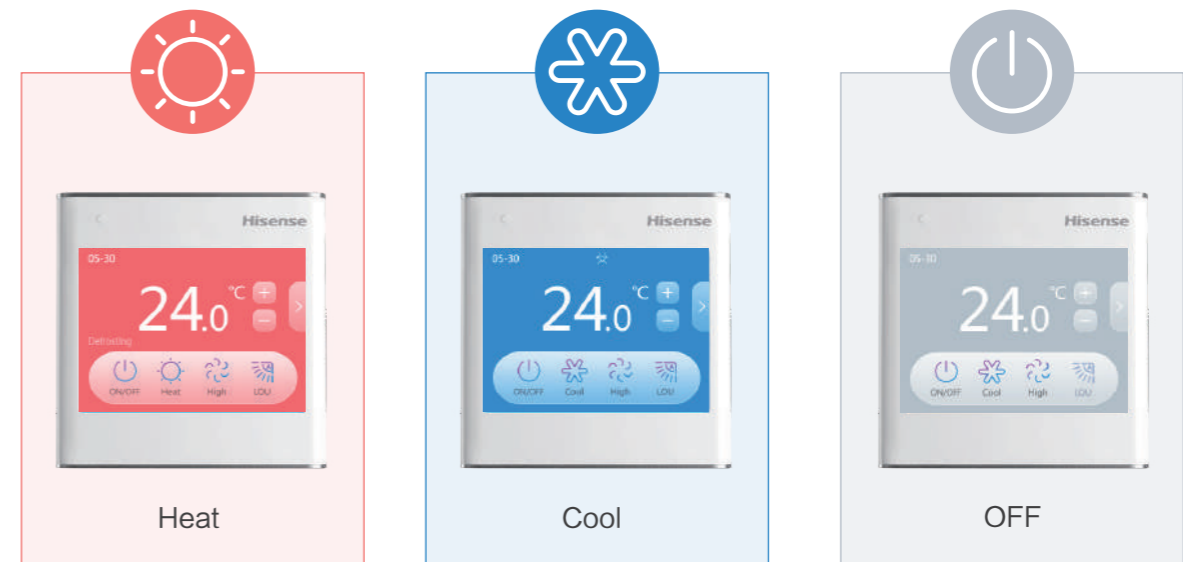

HYXE-VC01



Features

- Size: 86mm × 86mm
- Max. connectable indoor units: 6
- LCD display with back light
- Touch button
- Flat back-cover for easy mounting

Mode	Cool/Heat/Auto/Fan/Dry
Timer	24-hour timer
Maintenance	Error code/Parameter check/Auto test run/ Self diagnostic function/Indoor & Outdoor PCB checking/ Air filter cleaning reminding/IDU address setting
Louver	7 Louver setting/3D-air flow/ Individual louver control
Special function	Health/ECO/Quiet/Sleep/Self-cleaning
Fan speed	6
Temperature setting	0.5°C accuracy/Display the setting temp. or room temp.
Main-sub control	•
Wireless control available	•
Built-in temperature sensor	•

HYXE-VA01A



Features

- Size: 120mm × 120mm
- Max. connectable indoor units: 16
- LCD display
- Touch button

Mode	Cool/Heat/Auto/Fan/Dry
Timer	72-hour
Maintenance	Error code/Parameter check/Auto test run/ Indoor&Outdoor PCB checking/Self diagnostic function
Louver	Louver setting/Individual louver control/3D-air flow
Special function	Breeze mode/Motion sensor/Health/ECO/Quiet/ Sleep/Self-cleaning
Fan speed	6
Temperature setting	0.5°C
Main-sub control	•
Air filter cleaning reminding	•
Back light	•
Built-in temperature sensor	•

HYXE-J01H



Features

- Size: 120mm × 120mm
- Max. connectable indoor units: 16
- Touch button
- Language:
HYXE-J01H: English, Arabic.
HYXE-J01H1: English, Spanish,
Italian, German, Polish.
HYXE-J01H2: English, Turkish,
Russian, French, Dutch

Mode	Cool/Heat/Auto/Fan/Dry
Timer	24-hour/Weekly schedule/Holiday setting
Maintenance	Error code/Parameter check/Auto test run/ Indoor&Outdoor PCB checking/Self diagnostic function
Louver	Louver setting/Individual louver control/ 3D-air flow
Special function	Breeze mode/Motion sensor/Health/ Hi-Motion/ECO/Quiet/Sleep
Fan speed	6
Temperature setting	0.5°C
Main-sub control	•
Air filter cleaning reminding	•
Back light	•
Built-in temperature sensor	•

HYXE-S01H



Features

- Size: 120mm × 70mm
- Max. connectable indoor units: 16
- LCD display
- Touch button

Mode	Cool/Heat/Auto/Fan/Dry/Quiet
Timer	24-hour
Maintenance	Error code/Parameter check/Auto test run/ Indoor&Outdoor PCB checking/Self diagnostic function
Louver	Louver setting
Fan speed	6
Temperature control	•
Air filter cleaning reminding	•

Wireless Controller

HYE-VD01



Mode	Cool/Heat/Auto/Fan/Dry
Timer	24-hour timer
Maintenance	Auto test run/Self diagnostic function/ Identification of adjacent receiver
Louver	Louver setting/3D-air flow*/Individual louver control
Special function	Health/ECO/Quiet/Sleep/Self-cleaning
Fan speed	6
Temperature setting	1°C accuracy/Display the setting temp. or room temp.
Built-in temperature sensor	•

Features

- Size: 178.6mm × 47.8mm
- LCD display with back light

* When used to control 3D air-flow Panels, an additional receiver kit of wireless control will be necessary.

Centralized Control

Smart Touch

HYJM-S01H



Cool/Heat/Auto/Fan/Dry/ECO
Holiday setting
Filter cleaning reminder
External input/Output function
Temperature limitation
All/4 zone/Individual control

Features

- Size: 220mm × 148mm
- Max. connectable indoor units: 160
- Max. connectable indoor unit groups: 64
- Max. distance: 1000m
- Language:
Chinese, English, Russian, Spanish,
Turkish, German, Italian, Dutch,
Polish, Arabic

Receiver Kit for Wireless Control-Optional

HYRE-X01H

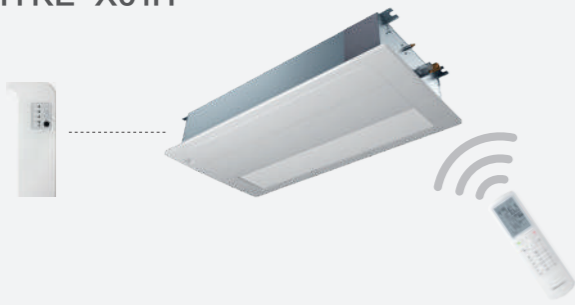

HYRE-V02H



HYRE-Z01H

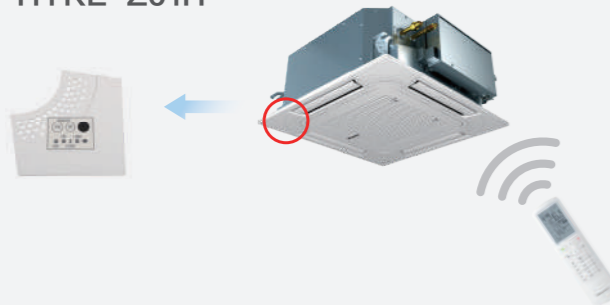

HYRE-T03H

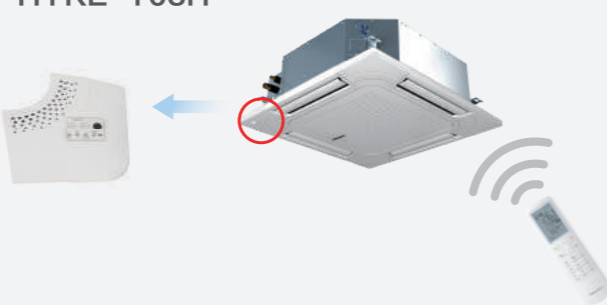

ON/OFF Controller

HYJ-J01H



Group control (ON/OFF)
Indoor unit power OFF reminder
Indoor units Auto log in
Error reminder

Features

- Size: 120mm × 120mm
- Max. connectable indoor units: 128
- Max. connectable indoor unit groups: 16
- Touch button

Intelligent Control

Hi-Mit II



Anytime and anywhere, control is in your hands

Brand-new Adapter and App

- Stylish appearance and compact body
- Compatible with VRF, hydro box and heat recovery ventilator
- Supporting OTA update
- Simple and intuitive interfaces

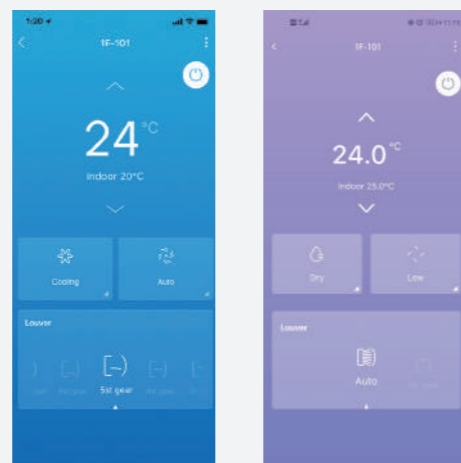

Convenient Control

- 12 languages available
- Energy management
- 2-level permission
- Online repair
- 7x24 schedule setting
- Customized scenes setting

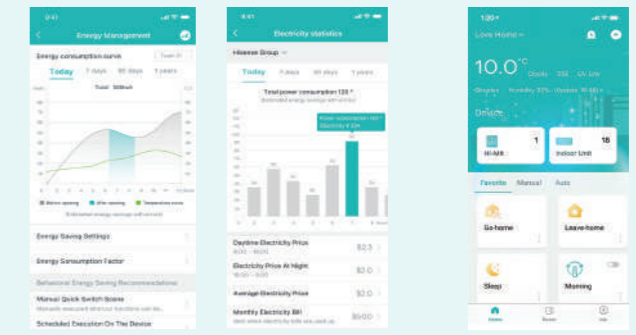

Energy management interface

Customized mode interface

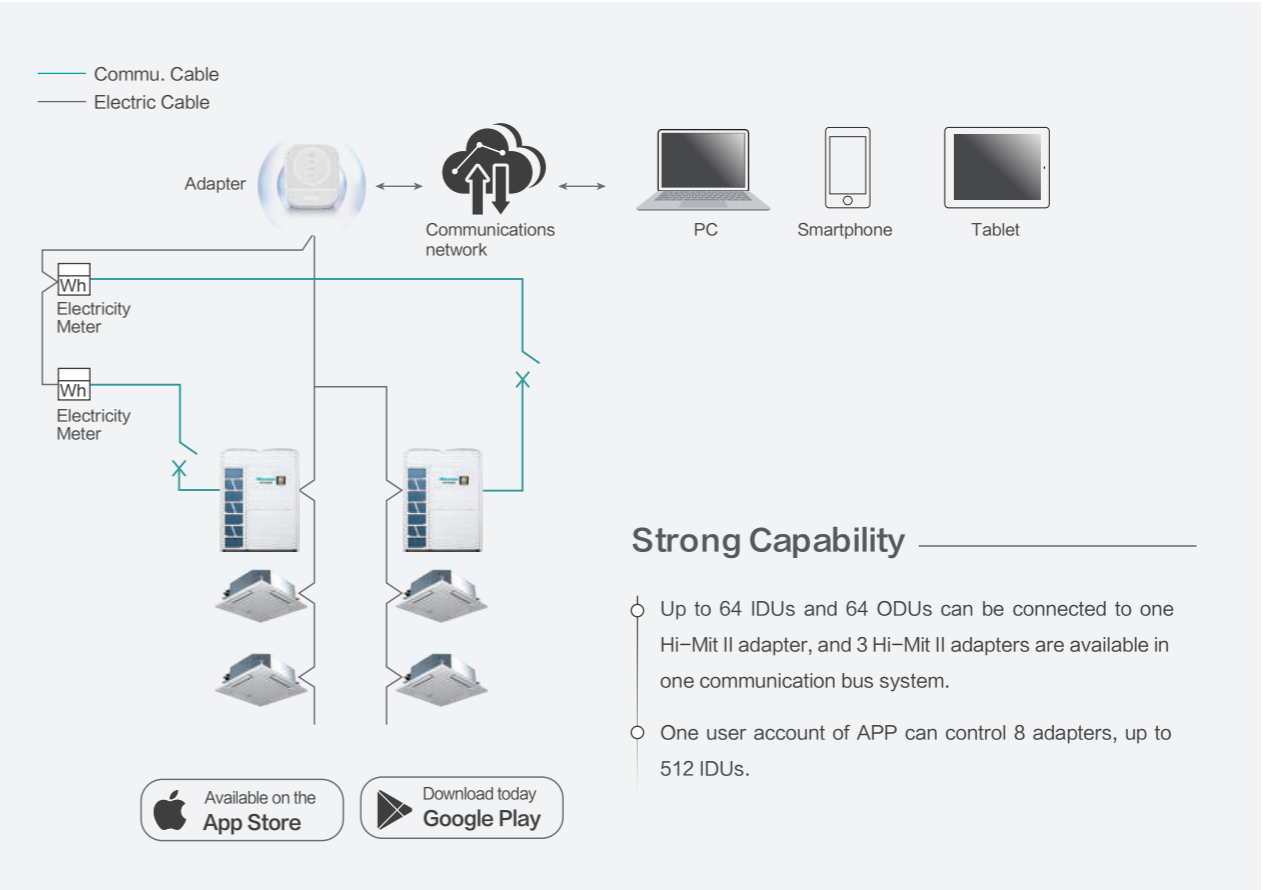

Strong Capability

- Up to 64 IDUs and 64 ODUs can be connected to one Hi-Mit II adapter, and 3 Hi-Mit II adapters are available in one communication bus system.
- One user account of APP can control 8 adapters, up to 512 IDUs.

Specifications

Model	Power Supply	Max. Current	Power Input	Dimension	Net Weight
HCCS-H64H2C1M	DC 12V	1A	2.4W	91x117x31mm	0.14kg

Hi-Dom III



Features

- Remote control available
- Multilevel user management
- AC control (on-off, mode, temp, air flow)
- AC locked control (running forbidden control, the max. and min. temp and cooling/heating locked)
- Running according to timer
- Malfunction history check
- Running record display
- Data synchronize
- Supporting for external I/O
- 2D navigation
- Electricity consumption allocation
- Multiple languages available
- Standard with Modbus RTU port

● Humanized interaction interface and comfortable user experience.

● The electricity consumption allocation makes it easy for users to allocate total electricity consumption among building occupants. Both segmented tariff and single tariff are available.

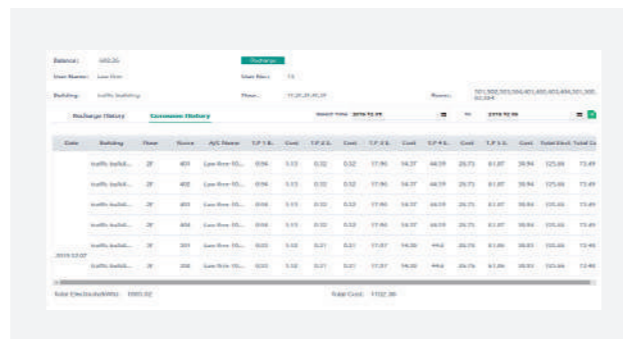
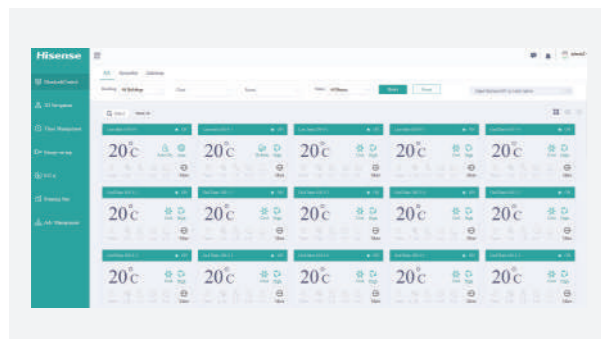

● Thanks to the 2D navigation, users can import floor plans and place indoor units in the corresponding rooms, creating a tailored system schematic. Thus all the indoor units can be monitored and controlled intuitively.

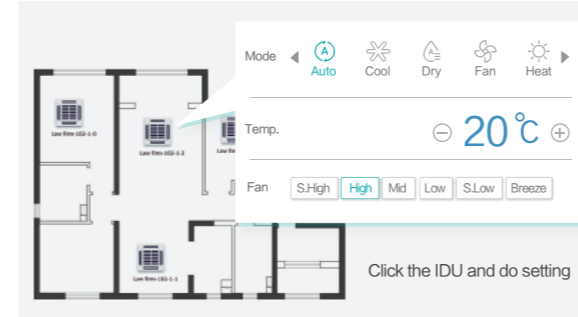

● Support operation history data record like the below picture. Also the operation data can be exported to excel format, convenient for customers to read.

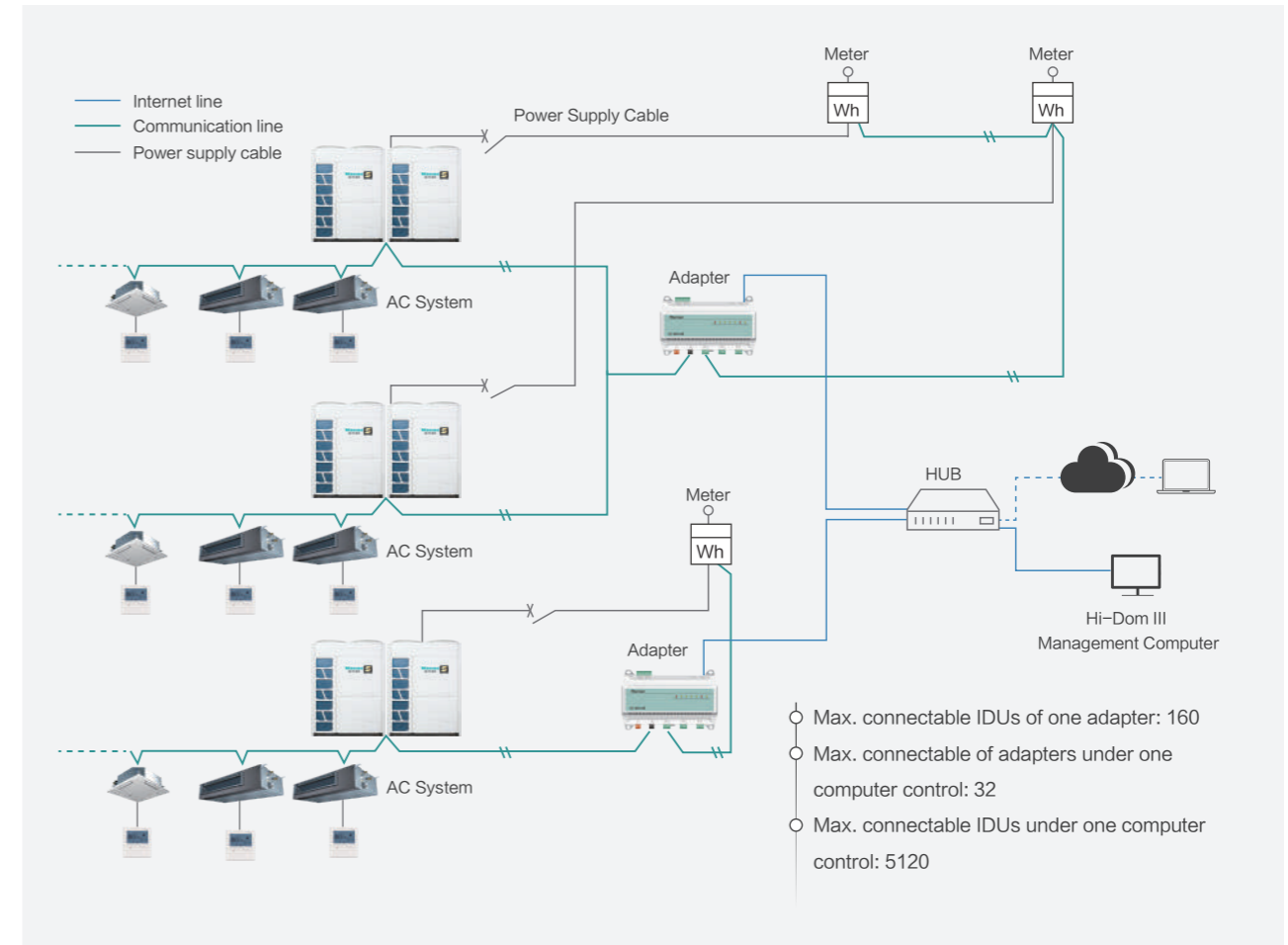
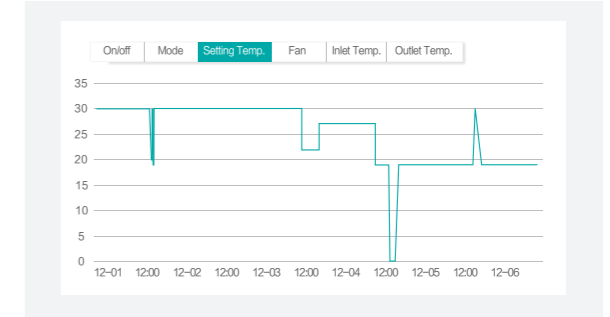

Specifications

Adapter	Model	Power Supply	Dimension (LxWxD)	Note
	HCCS-H160H2C2YM	12V	180x115.4x64.5mm	With electric charging function
	HCCS-H160H2C2NM	12V	180x115.4x64.5mm	Without electric charging function



Intelligent service tool, improves your service

Hi-Checker is a plug and play service tool, with which service engineers can access the system and monitor operation status or data, very convenient for system communication and maintenance. Besides, it features cloud-based management, easy to access operation status remotely.



Small and Portable Body



Remote Access



Black Box Function



Powerful Chats



OTA Update

Easy to Use

- Compact size which allows high portability and space saving.
- Capable to slot in a 32G memory card for data collection and storage. Also the memory card and card reader are standard with Hi-Checker.
- Multiple choices of power supply types. It can be powered by the standard adapter (DC 5V), computer or power bank.
- Support OTA update, ensuring the software is always up to date.



Easy to Access

4 Ways to Access the Operation Data

- Conventional connection type. The simplest and reliable way by just connecting the Hi-Checker to your computer directly through USB.
- Internet connection type. Be connected to a stable Wi-Fi signal to achieve operation data and status monitoring anytime and anywhere.
- Hotspot connection type. Be connected to a temporary hotspot signal from the smartphone, allowing the Hi-Checker to remotely monitor the operation data when there is no stable Wi-Fi signal on site.
- SD card storage type. Hi-Checker equipped with SD card can be connected to the air conditioning system all the time, so that all the operation data can be stored in the card for later analysis.

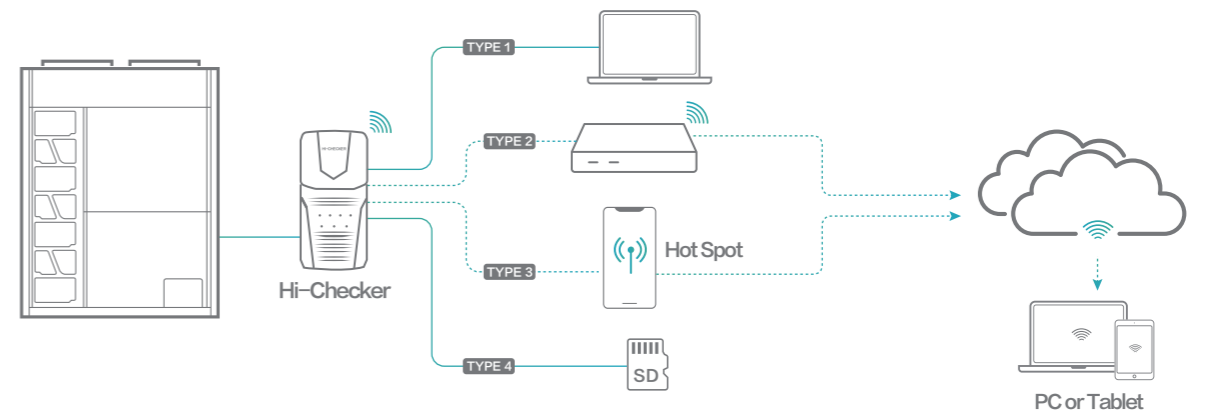

Easy to Understand

- Powerful and detailed chart analysis on the operation data, allowing users to determine the system condition easily. Together with the smart system diagram, it is interesting and easier for maintenance.
- Users can export the professional report either in .csv or .pdf format, very user-friendly.



Specifications

Mode	Size (LxWxH)mm	Net Weight (g)	Power Supply	Connectable IDUs
HCCS-H64H2C2M	138x68x28	130	5V=500mA	160

Building Management System

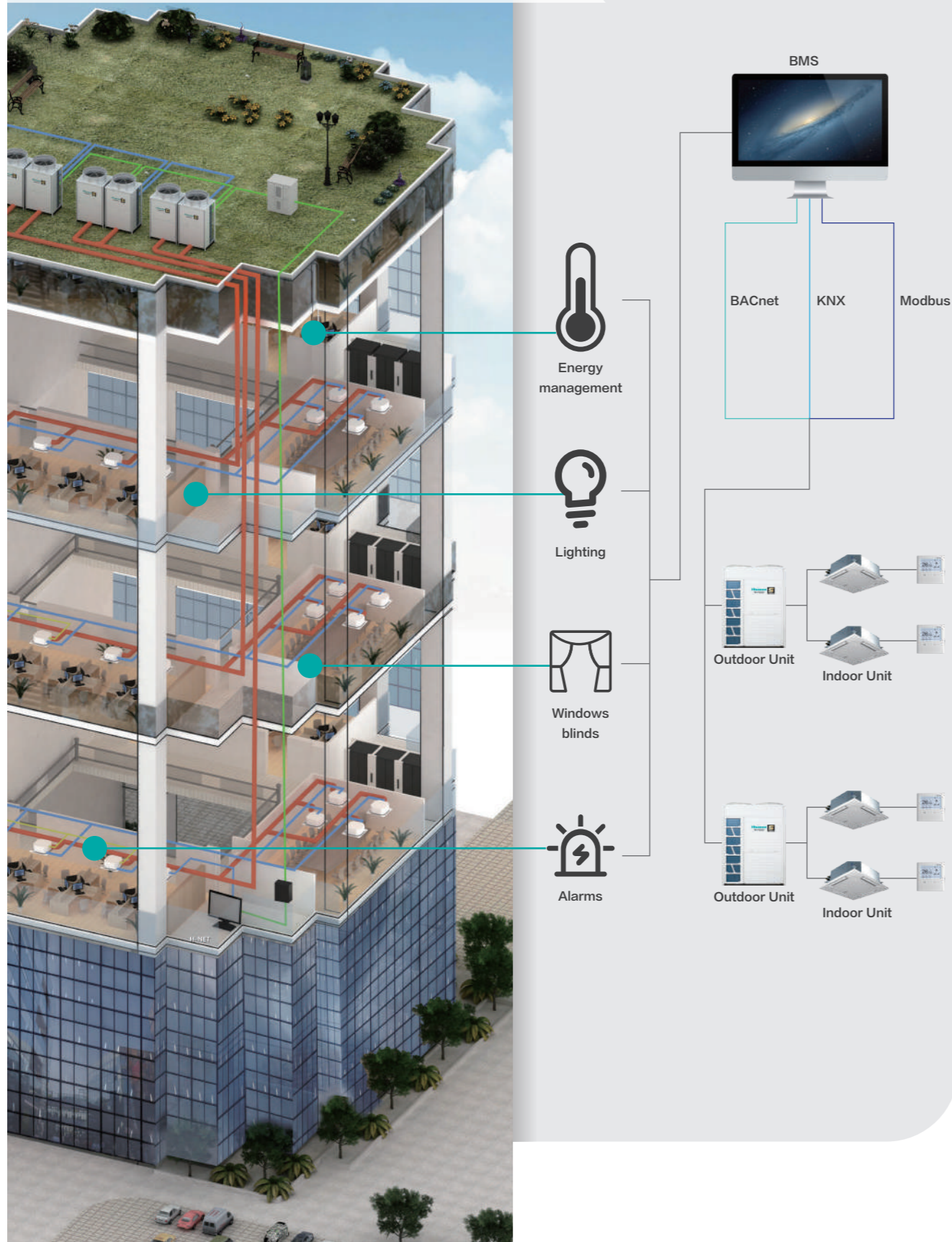

KNX®

KNX gateway	HS-RC-KNX-1i	HS-AC-KNX-16	HS-AC-KNX-64
Power Supply	DC, 29V	DC, 24V	DC, 24V
Max. Number of Connectable Indoor Units	1	16	64
Dimension (H x W x D)	70 x 70 x 28mm	56 x 88 x 90mm	56 x 88 x 90mm

- Features**
- Standard data point types
 - Directly control of all indoor units*2
 - Error code
 - Air filter reminder*2
 - Central control of all indoor units*1
 - Running hours counter*2
 - Easy to use tool for the configuration of Intesis box*1

Note: *1: Adapted for HS-AC-KNX-16, HS-AC-KNX-64. *2: Adapted for HS-RC-KNX-1i.

Modbus®

Modbus gateway	HCPC-H2M1C
Power Supply	DC, 12V
Max. Number of Connectable Indoor Units	64
Dimension (H x W x D)	70 x 204 x 240mm

- Features**
- On-Off setting
 - Airflow setting and monitoring
 - Temperature setting
 - All units On-Off control
 - Operating mode setting
 - Alarm monitoring and code display
 - Inlet air temperature monitoring

BACnet®

BACnet gateway	HS-AC-BAC-16	HS-AC-BAC-64
Power Supply	DC, 24V	DC, 24V
Max. Number of Connectable Indoor Units	16	64
Dimension (H x W x D)	56 x 88 x 90mm	56 x 88 x 90mm

- Features**
- Central control of all indoor units
 - Control-vane position swing control
 - Indoor unit data monitoring
 - Function prohibition of wired controller
 - Heat/Dry/Fan/Cool/Auto mode

Note: Bacnet® is a registered trademark of American Society of Heating, Refrigerating and Air-conditioning Engineers (ASHRAE).
 Modbus® is a registered trademark of Schneider Electric.
 KNX® is a registered trademark of Konnex.

ACCESSORIES & ENGINEERING TOOLS

ACCESSORIES & ENGINEERING TOOLS

Accessories

Engineering Tools

Accessories

Hi-Motion

Model	Applicable Models	Picture
HCM-S01E	All types of indoor units	

Motion Sensor

Model	Applicable Models	Picture
HPS-MACN	Mini 4-Way Cassette Type	
HCM-01E	4-Way Cassette Type	

Fresh Air Duct Adapter

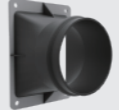
Model	Applicable Models	Picture
HFL-56CSA	4-Way Cassette Type and Mini 4-Way Cassette Type	

Humidity Sensor



Model	Applicable Models	Picture
HCHR-S01E	4-Way Cassette Type, Console, Ceiling Ducted Typee	

Filter

Filter model	Filter Dimension	Frame Dimension	Application Models	Picture
HF-224L-FE	910 × 432.5mm	1055 × 463mm	AVD-76UX6SEH/L	
HF-280L-FE	1100 × 432.5mm	1245 × 463mm	AVD-76/96HJFH AVD-96UX6SFH/L	

Filter box model	Dimension (L × W × H) mm	Applicable Models	Applicable Filter	Picture
HFB-96LFGDE	1339 × 384 × 462	AVD-76/96HJFH	High-efficiency filter:HF-96HFGDE Coarse filter:HF-96LFGDE	

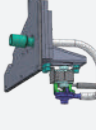

Drain Pump

Model	Applicable Models	Power Supply	Picture
HPS-F133E	AVD-07-24HJFH / AVD-07-24HCFC / AVD-07-24HCFL	220-240V/50Hz	
HPS-F363E	AVD-24HJFH1 / AVD-30-54HJFH / AVD-27-54HCFC / AVD-27-54HCFL		
HPS-F134E	AVD-07-24H3FCH	208-230V/60Hz	
HPS-F364E	AVD-27-54H3FCH		
HPS-151	All the High/Low Static Pressure Ceiling Ducted Units and All Fresh Air IDU 3-10HP	220-240V/50/60Hz	
HPS-F8103E	AVD-76/96HJFH	220-240V/50/60Hz	

3D Air-flow Panel

Panel Model	Applicable Models	Outer Dimensions (H × W × D)	Picture
HP-CB-NA	Ceiling ducted type (DC / AC low-height) 0.5-1.3HP	180 × 740 × 70mm	
HP-DB-NA	Ceiling ducted type (DC / AC low-height) 1.5-1.8HP	180 × 950 × 70mm	
HP-EB-NA	Ceiling ducted type (DC / AC low-height) 2-2.5HP	180 × 1220 × 70mm	

AirPure Kit

Model	Power Supply	Applicable Indoor Units	Picture
HJK-ELZA	AC 1Φ, 220V-240V 50/60Hz	4-Way Cassette Type, Mini 4-Way Cassette Type	
HJK-ELZB	AC 1Φ, 220V-240V 50/60Hz	Ceiling Ducted, Console	

Voltage Protector

Model	Power Supply	Dimension (H × W × D)	Picture
HOPT-EOUPA01	AC 3Φ, 380V-415V/50Hz	295 × 222 × 103mm	

Note: Suitable for Hi-FLEXi S series, S series heat recovery unit and S mavo+ unit.

Piping Connection Kit

Manifold Pipe (For outdoor unit)

(Indoor Unit on Left Side)

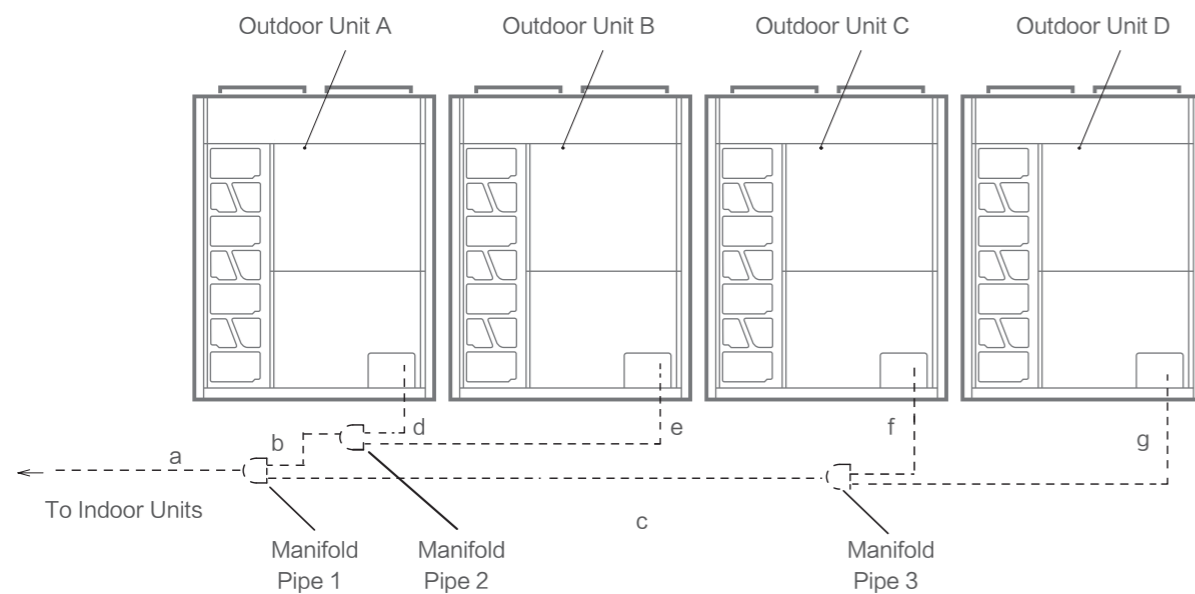

For S Series Heat Recovery 2 Pipes System

Outdoor Unit	AVWT-290-522FKFSA	AVWT-544FKFSA	AVWT-552-634FKFSA	AVWT-654-794FKFSA	AVWT-816FKFSA	AVWT-824-968FKFSA	AVWT-988-1066FKFSA	AVWT-1088FKFSA
Manifold Pipe1	HFQ-M32F	HFQ-M462F	HFQ-M462F	HFQ-M682F	HFQ-M682F	HFQ-M682F	HFQ-M682F	HFQ-M682F
Manifold Pipe2	-	-	HFQ-M32F	HFQ-M32F	HFQ-M462F	HFQ-M32F	HFQ-M462F	HFQ-M462F
Manifold Pipe3	-	-	-	-	-	HFQ-M32F	HFQ-M32F	HFQ-M462F

For S Series Heat Recovery System

Outdoor Unit	AVWT-290-344FKFSA	AVWT-360-522FKFSA	AVWT-544FKFSA	AVWT-552FKFSA	AVWT-570-634FKFSA	AVWT-654-794FKFSA	AVWT-816FKFSA	AVWT-824-968FKFSA	AVWT-988-1066FKFSA	AVWT-1088FKFSA
Manifold Pipe1	HFQ-M212F	HFQ-M302F	HFQ-M462XF	HFQ-M462XF	HFQ-M462XF	HFQ-M682XF	HFQ-M682XF	HFQ-M682XF	HFQ-M682XF	HFQ-M682XF
Manifold Pipe2	-	-	-	HFQ-M212F	HFQ-M302F	HFQ-M302F	HFQ-M462XF	HFQ-M302F	HFQ-M462XF	HFQ-M462XF
Manifold Pipe3	-	-	-	-	-	-	-	HFQ-M302F	HFQ-M302F	HFQ-M462XF

For S Series System

Outdoor Unit	AVWT-290-422HKSS	AVWT-444-544HKSS	AVWT-552-634HKSS	AVWT-654HKSS	AVWT-676-816HKSS	AVWT-824-886HKSS	AVWT-908-1088HKSS
Manifold Pipe1	HFQ-M32F	HFQ-M462F	HFQ-M462F	HFQ-M682F	HFQ-M682F	HFQ-M682F	HFQ-M682F
Manifold Pipe2	-	-	HFQ-M32F	HFQ-M32F	HFQ-M462F	HFQ-M462F	HFQ-M462F
Manifold Pipe3	-	-	-	-	-	HFQ-M32F	HFQ-M462F

For S mavo+ Series System

Outdoor Unit	AVWT-290-422HKFSEA	AVWT-444-544HKFSEA	AVWT-552-634HKFSEA	AVWT-654-696HKFSEA	AVWT-714-816HKFSEA	AVWT-824-886HKFSEA	AVWT-908-1088HKFSEA
Manifold Pipe1	HFQ-M32F	HFQ-M462F	HFQ-M462F	HFQ-M682F	HFQ-M682F	HFQ-M682F	HFQ-M682F
Manifold Pipe2	-	-	HFQ-M32F	HFQ-M32F	HFQ-M462F	HFQ-M462F	HFQ-M462F
Manifold Pipe3	-	-	-	-	-	HFQ-M32F	HFQ-M462F

For X Series System

Outdoor Unit	AVWT-172-229UESZX	AVWT-250-307UESZX	AVWT-324-386UESZX	AVWT-404-460UESZX	AVWT-480-620UESZX
Manifold Pipe1	HFQ-M22F	HFQ-M32F	HFQ-M32F	HFQ-M32F	HFQ-M462F
Manifold Pipe2	-	-	HFQ-M22F	HFQ-M32F	HFQ-M32F
Manifold Pipe3	-	-	-	-	HFQ-M32F

Branch Pipe (For indoor unit)

First Branch Pipe

For S Series Heat Recovery 2 Pipes System

Outdoor Unit HP	8 to 10	12 to 16	18 to 24	26 to 54	56 to 66	68 to 112
Branch Pipe	HFQ-102F	HFQ-162F	HFQ-242F	HFQ-302F	HFQ-462F	HFQ-682F

For S Series Heat Recovery System

Outdoor Unit HP	8 to 10	12 to 16	18 to 24	26 to 36	38 to 54	56 to 66	68 to 112
Branch Pipe	HFQ-M282F	HFQ-M452F	HFQ-M562F	HFQ-M692F	HFQ-M902F	HFQ-462XF	HFQ-682XF

For S/S mavo+ Series System

Outdoor Unit HP	8 to 10	12 to 16	18 to 24	26 to 44	46 to 66	68 to 112
Branch Pipe	HFQ-102F	HFQ-162F	HFQ-242F	HFQ-302F	HFQ-462F	HFQ-682F

For X Series System

Outdoor Unit HP	8 to 10	12 to 16	18 to 24	26 to 48	50 to 64
Branch Pipe	HFQ-102F	HFQ-162F	HFQ-242F	HFQ-302F	HFQ-462F

First Branch Pipe~Last Branch Pipe

For S Series Heat Recovery 2 Pipes System

Total Indoor Unit Hp	Lower than 6	6 to 8.99	9 to 11.99	12 to 15.99	16 to 17.99	18 to 25.99	26 to 35.99	36 to 55.99	56 to 57.99	58 to 67.99	Over 68
Gas (mm)	15.88	19.05	22.2	25.4	28.6	28.6	31.75	38.1	41.3	44.5	50.8
Liquid (mm)	9.53	9.53	9.53	12.7	12.7	15.88	19.05	19.05	22.2	22.2	25.4
Branch Pipe	HFQ-102F	HFQ-102F	HFQ-102F	HFQ-162F	HFQ-162F	HFQ-242F	HFQ-302F	HFQ-302F	HFQ-462F	HFQ-462F	HFQ-682F

For S Series Heat Recovery System

Total Indoor Unit Hp	Lower than 6	6 to 8.99	9 to 11.99	12 to 15.99	16 to 17.99	18 to 21.99	22 to 25.99	26 to 35.99	36 to 55.99	56 to 57.99	58 to 67.99	Over 68
Low Pressure Gas (mm)	15.88	19.05	22.2	25.4	28.6	28.6	28.6	31.75	38.1	41.3	44.5	50.8
High/Low Pressure Gas (mm)	12.7	15.88	19.05	22.2	22.2	22.2	25.4	28.6	31.75	38.1	41.3	44.5
Liquid (mm)	9.53	9.53	9.53	12.7	12.7	15.88	15.88	19.05	19.05	22.2	22.2	25.4
Branch Pipe	HFQ-M142F	HFQ-M282F	HFQ-M282F	HFQ-M452F	HFQ-M562F	HFQ-M562F	HFQ-M692F	HFQ-M692F	HFQ-M902F	HFQ-462XF	HFQ-462XF	HFQ-462XF

For S/S mavo+ Series System

Total Indoor Unit Hp	Lower than 6	6 to 8.99	9 to 11.99	12 to 15.99	16 to 17.99	18 to 25.99	26 to 33.99	34 to 45.99	46 to 58.99	59 to 68.99	Over 69
Gas (mm)	15.88	19.05	22.2	25.4	28.6	28.6	31.75	38.1	41.3	44.5	50.8
Liquid (mm)	9.53	9.53	9.53	12.7	12.7	15.88	19.05	19.05	22.2	22.2	25.4
Branch Pipe	HFQ-102F	HFQ-102F	HFQ-102F	HFQ-162F	HFQ-162F	HFQ-242F	HFQ-302F	HFQ-302F	HFQ-462F	HFQ-462F	HFQ-682F

For X Series System

Total Indoor Unit Hp	Lower than 6	6 to 8.99	9 to 11.99	12 to 15.99	16 to 17.99	18 to 25.99	26 to 35.99	36 to 47.99	48 to 57.99	58 to 64
Gas (mm)	15.88	19.05	22.2	25.4	28.6	28.6	31.75	38.1	41.3	44.5
Liquid (mm)	9.53	9.53	9.53	12.7	12.7	15.88	19.05	19.05	22.2	22.2
Branch Pipe	HFQ-102F	HFQ-102F	HFQ-102F	HFQ-162F	HFQ-162F	HFQ-242F	HFQ-302F	HFQ-302F	HFQ-462F	HFQ-462F

Last Branch Pipe~Indoor Unit

Indoor Unit	Pipe Size (Φmm)		Max. Liquid Pipe Length
	Gas Pipe	Liquid Pipe	
7kBTu/h~14kBTu/h	12.70	6.35*1	40
17kBTu/h~18kBTu/h	15.88	6.35*1	40
22kBTu/h~54kBTu/h	15.88	9.53	40
76kBTu/h	19.05	9.53	40
96kBTu/h	22.20	9.53	40

Note: 1. When liquid pipe length of indoor unit (07~18kBTu/h) is more than 15m, please change the liquid pipe dimension from Φ6.35 into Φ9.53.

Manifold Pipe Parameter

Model	Gas Line	Liquid Line	Reducer for Gas Line	Reducer for Liquid Line
HFQ-M32F#E				
HFQ-M462F#E				
HFQ-M682F#E				

Model	Low Pressure Gas Line	High Pressure Gas Line	Liquid Line	Reducer for Low Pressure Gas Line	Reducer for High Pressure Gas Line	Reducer for Liquid Line
HFQ-M212F#E						
HFQ-M302F#E						
HFQ-M462XF#E						
HFQ-M682XF#E						

Unit: mm, ID: Inner Diameter, OD: Outer Diameter.

Branch Pipe Parameter

Model	Low Pressure Gas Line	High Pressure Gas Line	Liquid Line	Reducer for Low Pressure Gas Line	Reducer for High Pressure Gas Line	Reducer for Liquid Line
HFQ-M142F#E				—	—	
HFQ-M282F#E				—	—	
HFQ-M452F#E						
HFQ-M562F#E						
HFQ-M692F#E						
HFQ-M902F#E						
HFQ-462XF#E						
HFQ-682XF#E						

*For the models shown in the table, there is no insulation included. If insulation is needed, please contact with our local engineer.

Branch Pipe Parameter

Model	Gas Line	Liquid Line	Reducer for Gas Line	Reducer for Liquid Line
HFQ-052F#E			—	—
HFQ-102F#E			—	
HFQ-162F#E				
HFQ-242F#E				
HFQ-302F#E				
HFQ-462F#E				
HFQ-682F#E				

Unit: mm, ID: Inner Diameter, OD: Outer Diameter.

RELIABILITY
EFFICIENCY
COMFORT
FLEXIBILITY
OUTDOOR UNIT
INDOOR UNIT
CONTROL SYSTEM
ACCESSORY

Engineering Tools

Hi-Selection Software

Hi-Selection software developed by Hisense VRF is a Windows based program which support Windows XP and higher operating systems. It offers multiple languages to allow and eases users from different countries. Latest product specification and information could be obtained from the software as it supports database updates. The highlight of the software being architectural floor plans and drawings of any formats, be it a DWG, PDF, JPG or PNG could be imported either be exported at the end of the design. With the software, equipment selection, piping and wiring drawing could be done automatically at the tips of your fingers.

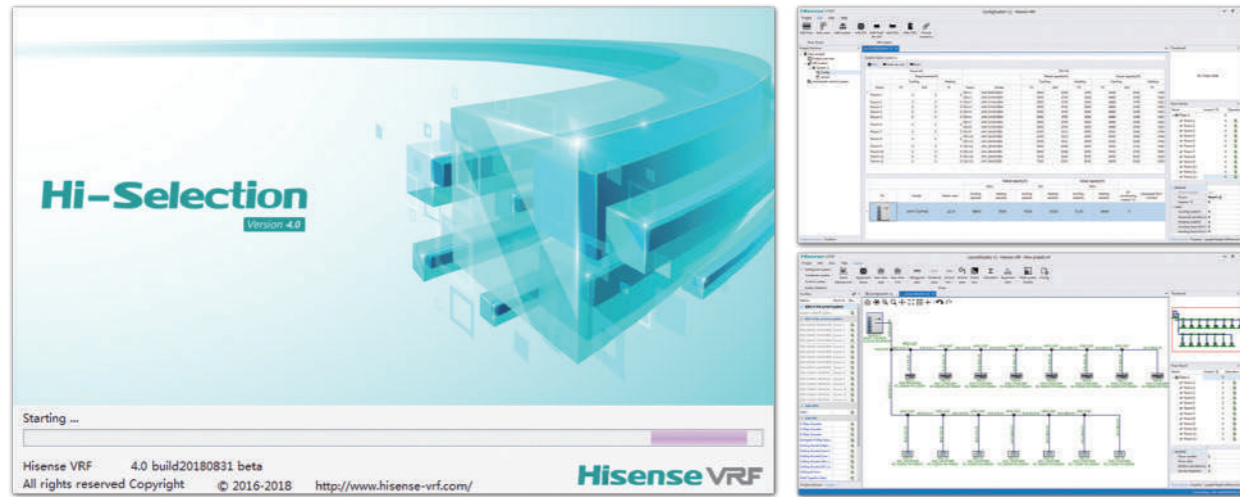

Design Software

Hisense VRF design software is a AUTOCAD plug-in, supporting AUTOCAD version 2008 to 2020 in both 32-bit and 64-bit operating system. It consists of the complete online up-to-date product range database. Functions offer by the software include system piping calculation, refrigerant charge amount and many more.



CFD

Hisense VRF offers Computational Fluid Dynamics (CFD) simulations as named as the best method to analyze building airflow ventilation. The simulation provides detailed and easy-to-understand results at the end of the simulation with colors and lines contours according to personal preferences.

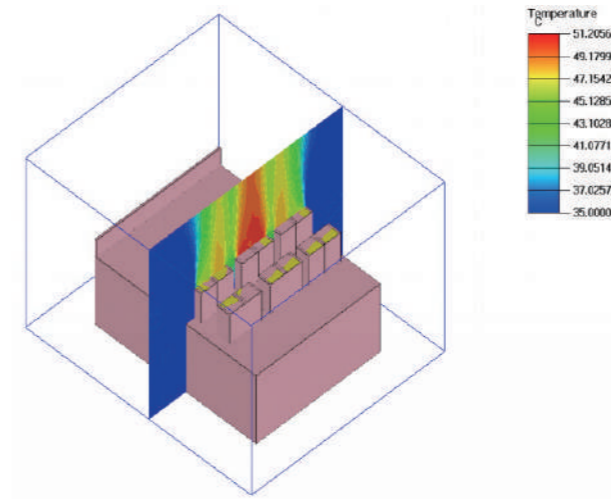

BIM

Building Information Modelling (BIM) is an umbrella term to cover many aspects of building modeling. With the Revit families and 3D models provides by Hisense.



GCSS

Hisense Global Customer Service System (GCSS) is an after-sales online website-based administration system widely offering to Hisense certified service partners and agents whereby improving customer's after-sales convenience and efficiency. 4 main services offered by the website include life-cycle project management, spare part and order delivery management and monitoring, warranty claim and online center hotline.

