



هورسان توان سپند  
Hoorsan Tavan Sepand

**Hisense**

**Hisense**



**CHILLER**

GENERAL CATALOGUE

Reimagine your solution



# Hisense SINCE 1969

Hisense Group is a well-known large-scale electronic information industry group company. Based on technology and focusing on innovation-oriented culture, its scientific and efficient technological innovation system makes Hisense always be at the forefront of the counterparts. Hisense brand family has continued to grow with Toshiba, Gorenje and ASKO. Multi-brand operations will be defined according to Group's Strategy Management Department.

# MANUFACTURING BASE

Qingdao Hisense HVAC Equipment Co., Ltd. is a wholly owned subsidiary of Qingdao Hisense Hitachi Air-conditioning Systems Co., Ltd., who is a joint-venture of Hisense and Hitachi (changed to Johnson Control Hitachi in 2015) and was established in 2003. It integrates technology development for commercial and residential CAC, product manufacturing, marketing and service as a whole. With solid technical innovation strength, Hisense VRF has participated in the formulation and revision of 25 national standards, industry standards and association standards, and has 420 authorized patents in the field of CAC and heat pump products. Since 2008, 58 technologies have reached the advanced level through authorized certification. Now Hisense VRF has become a leading CAC enterprise in China.

Note: The above data is valid before Dec. 31th, 2020.



266,000 m<sup>2</sup>  
Manufacturing Area



40+  
Production Line



6,000,000 units/year  
Production Capacity



16,700 m<sup>2</sup>/70+  
Laboratory



# CONTENTS



AIR-COOLED  
MODULAR CHILLER

03

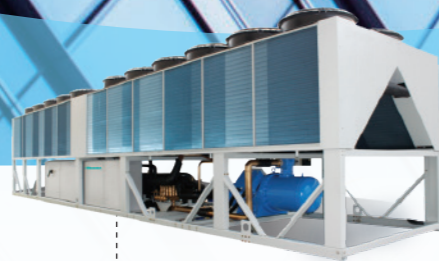

AIR-COOLED  
SCREW CHILLER

35



WATER-COOLED  
SCREW CHILLER

49



AIR  
HANDLING UNIT

65



CEILING  
SUSPENDED AHU

87

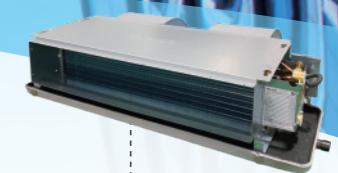

FAN  
COIL UNIT

96

# Hi-Mod Series

## AIR-COOLED MODULAR CHILLER

The new generation of air-cooled modular chiller Hi-Mod series has a series of products with full function and various specifications, including standard type A series, low temperature and strong heating type E series and ultra-low temperature and strong heating type H series. Modules of the same type can be connected freely, meeting the customized demands.

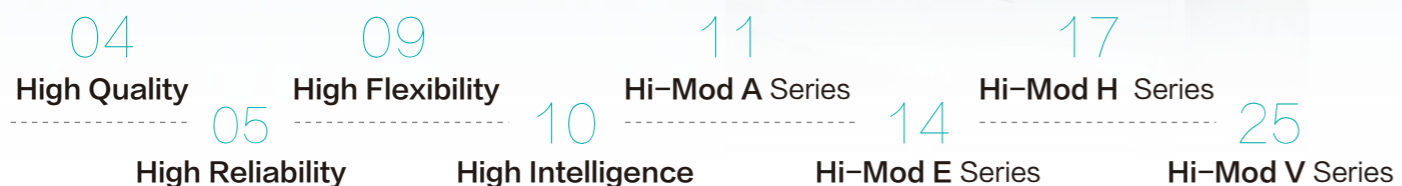

## HIGH QUALITY

### Components strictly screened

#### Smart Dual System, Flexible Operation

The innovative dual-system V-shaped high efficiency fin-type heat exchangers are applied in Hi-Mod series, and the two systems are independent, which could solve the problems related to the dependency of two-system operation.

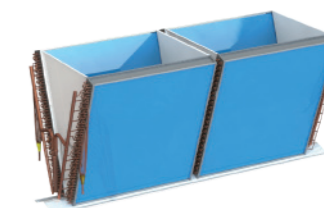

#### High-accuracy Electronic Expansion Valve

- High-accuracy electronic expansion valves are used for heating and cooling to dynamically control the opening of the valve according to the changes of environment and water temperature, minimizing the fluctuations of system pressure and temperature and ensuring stable operation.
- The system has dynamic over-heat control function to accurately control the flow of refrigerant and ensures no remaining liquid refrigerant after evaporation.
- Control accurately with 480-step control.

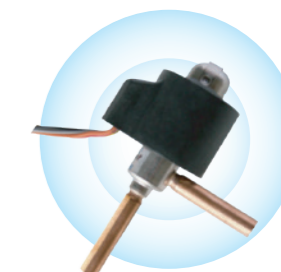

#### IP55-class Three-phase Fan Motor

- The fan motor in the airside is hermetically-sealed air-cooled squirrel cage three-phase fan motor, equipped with overheating protection function.
- Satisfy the IP55.



#### Dual Forward Flowing, Ensuring Reliability and Safety

Common electronic expansion valve always works like that refrigerant flows forward under cooling and flows reversely under heating. For this product, a dedicated one-way valve is built in the pipeline of the refrigerant. The refrigerant flow for cooling and heating are both forward, which effectively solves the problem of low reverse pressure bearing ability of the EEV, avoiding the over-pressure risk of EEV during reserve flowing, ensuring a more reliable operation.

#### High-efficiency Shell-and-Tube Evaporator

- High-efficiency inner-screw shell-and-tube heat exchanger is applied in the water side.
- A stable heat exchange performance is ensured with less requirements for water quality and not easy to be blocked by mineral or impurities.
- Much more reliable than the plate heat exchanger thanks to its great anti-freezing ability.
- Target flow switch is standard, which can shut down the unit in case of water supply failure, ensuring safety.
- With built-in screw-type baffle plates, the flowing resistance and the energy consumption of pump both are largely reduced.

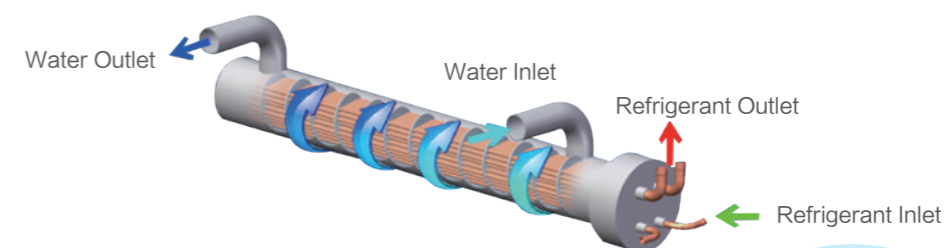



# HIGH RELIABILITY

## Stable Operation, Reliable and Efficient

### Rotational Operation of Compressors

The control system can record the working condition and accumulated working time of each compressor, and balance the allocation of the running time of each compressor intelligently. The compressor with short accumulated running time is firstly started when loading, while the compressor with long accumulated running time is firstly stopped when unloading, so as to extend the overall system's lifetime.

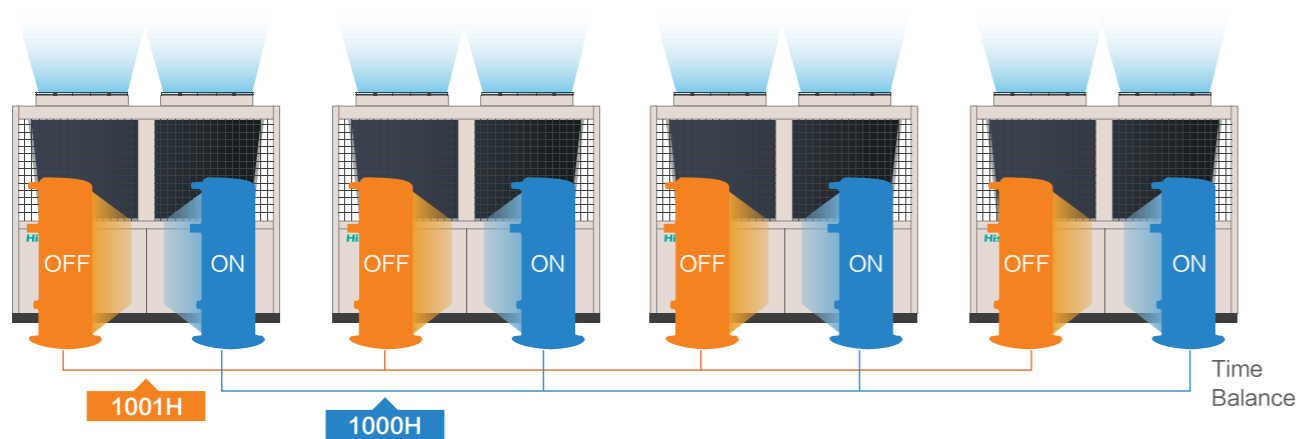

### Anti Liquid Slugging Technology

There are electrical heating elements covering the crankcase of the compressor, which makes sure that the compressor is in a good lubrication state when standby in winter. The liquid refrigerant can be evaporated fully, preventing liquid slugging to the compressor on starting.



### Intelligent Energy Regulation Technology

The technology always ensures that each module has at least one system working for multi-module combined unit, which can balance and adjust the temperature difference between inlet and outlet water for each module under partial load, avoiding much larger temperature difference and improving the system efficiency under partial load. Besides, temperature sensors are set on the inlet and outlet water pipes, which can monitor the real-time water temperature and control the on-off of the compressor according to the load changing.

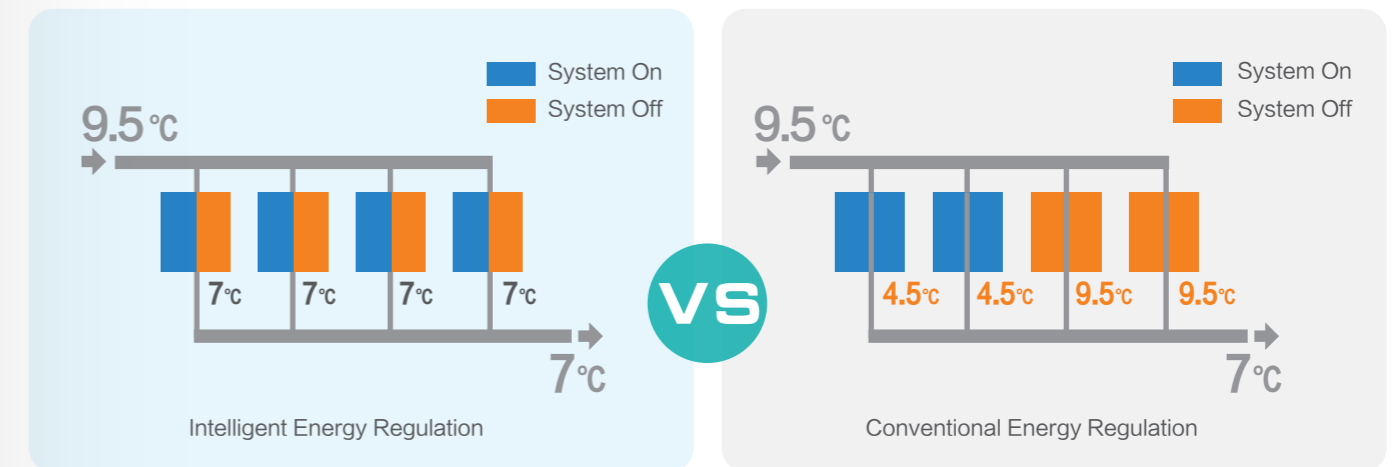

### Backup Operation

- Independent refrigerant loops in each module can realize emergency standby operation.
- The modules in one multi-module unit can realize emergency standby operation.





### Intelligent Defrost

- The defrosting time is more accurate thanks to the innovative dual heat exchanger system.
- The left and right coils of the heat exchanger are respectively equipped with temperature sensors, and the defrosting can be accurately controlled according to the sensor values together with ambient temperature and running time.
- Defrosting time can be automatically adjusted, avoiding ineffective defrosting and prolonging the defrosting interval. The efficiency under heating is largely improved.
- Rotational defrosting can be achieved for module combination unit, fully guaranteeing the heating effect.

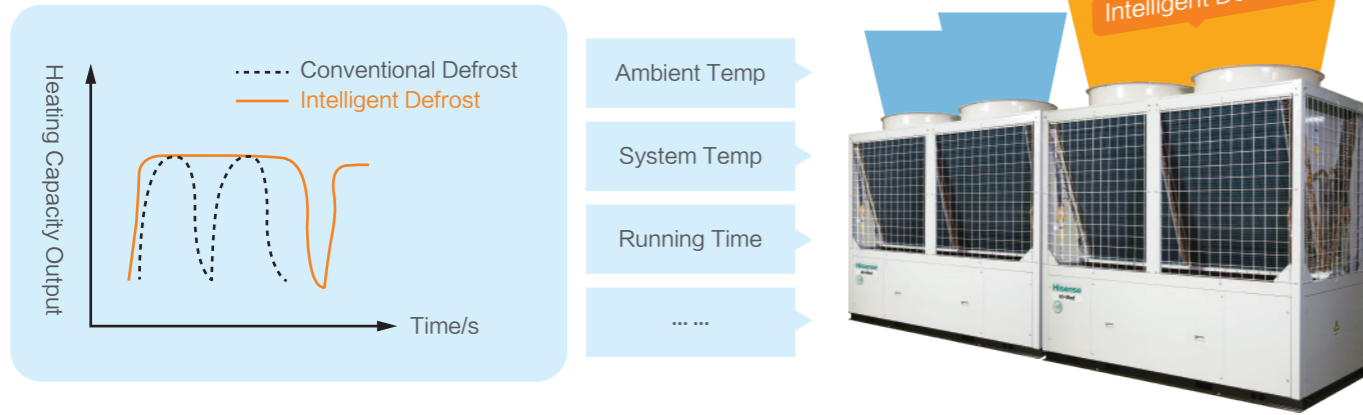

### Consecutive Heating Ensuring High Efficient Operation

The two systems of each unit are independent of each other. When one system defrosts, the other system can work normally, effectively reducing the fluctuation of water temperature and improving the users' comfort. When the module-combined units work, the control system will balance the defrosting time of each module, so as to prevent every module from entering defrosting at the same time. The modules without defrosting will continue to work normally, ensuring a consecutive heating.

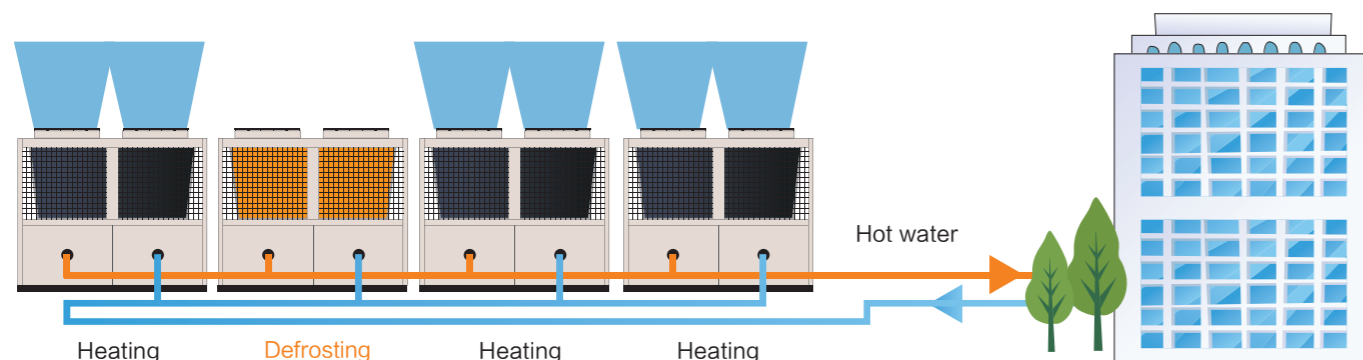

### Defrost Can Be Performed Manually, Responding to Harsh Environment

In case of heavy snow cover, thick frost layer formed due to high humidity in the environment or ice formed due to severe low temperature, the defrosting can be performed compulsively by human, ensuring the lasting and reliable heating operation.

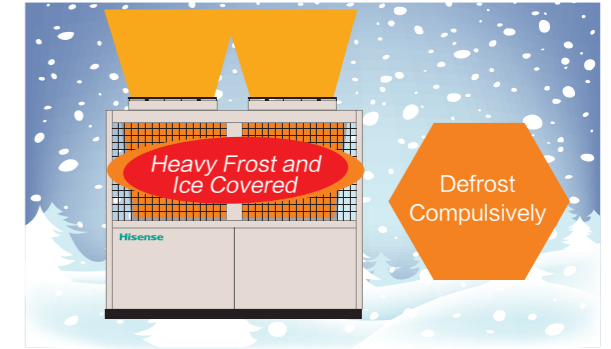

### Multiple Protections Ensuring Safety and Stability

- Various protections for compressors, fan motor, water flow, high and low refrigerant pressure, water temp, power supply, current and communication are fully considered and designed ahead.
- Water flow switch is standard part, and there are multiple anti-freeze protections, protecting against freezing and setting off.
- Anti-freezing function will be automatically conducted according to the ambient temperature and inlet and outlet water temperature, to prevent the water system from freezing during standby state.
- There is a minimum operation time for the compressor, to prevent the compressor from damage due to frequent starts and stops.





# HIGH FLEXIBILITY

## Flexible Installation and Convenient Transportation

### Module Design, More Convenient for Installation and Transportation

- The main and sub units are designed without difference, and any unit can be set as the main unit, which makes the combination and installation more convenient.
- Unit with different specifications of the same series can be connected freely to achieving large capacity output, and one controller can control up to 16 units, which is convenient to satisfy the various capacity cases.

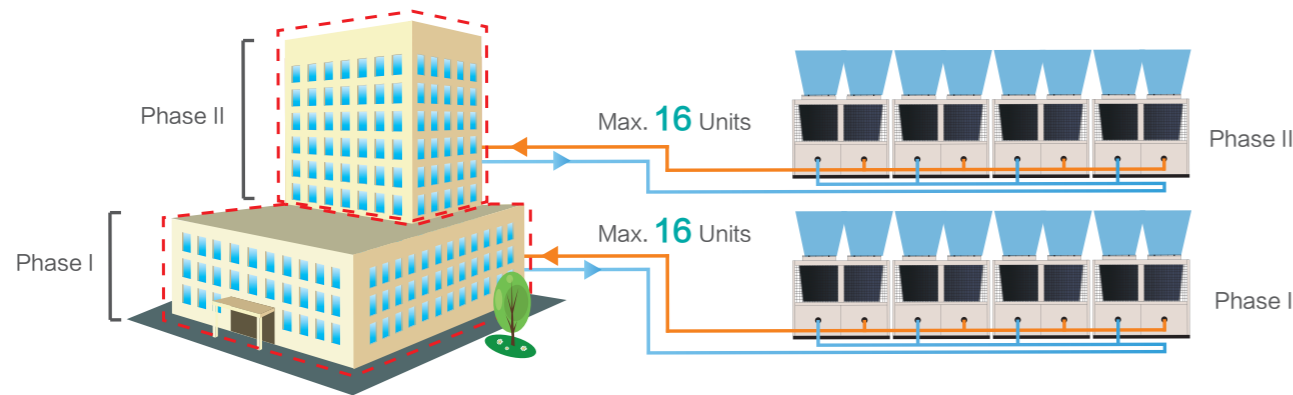

\* Hi-Mod A series has two base module, which can achieving capacity combination between 65kW and 2080kW.  
Hi-Mod E series has two base module, which can achieving capacity combination between 65kW and 2080kW.  
Hi-Mod H series has two base module, which can achieving heating capacity combination between 72kW and 2576kW.

### Compact Body, Flexible and Convenient Installation

- The integral structure design effectively reduces the unit volume and occupied area, greatly saving space and cost of installation.
- The minimum occupied area is only 1.89m<sup>2</sup>, decreased by more than 42% compared with other traditional modules in the industry.

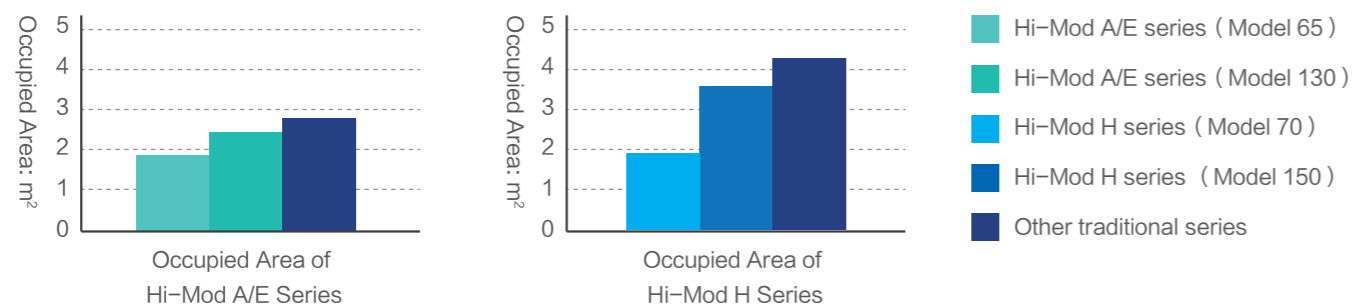

# HIGH INTELLIGENCE

## Intelligent Control, Smart and Convenient

### Intelligent Controller

Comprehensive information display, easy to understand

- Mode setting
- Inlet and outlet water temperature setting
- Compressor, pump, heater and defrost state control
- Malfunction information display
- Time setting
- Schedule setting
- Central control



### Connected to BMS

RS-485 signal interface is built in the controller, through which the unit can be connected to BMS. The interconnection of centralized control system realizes the networking group control and remote control.

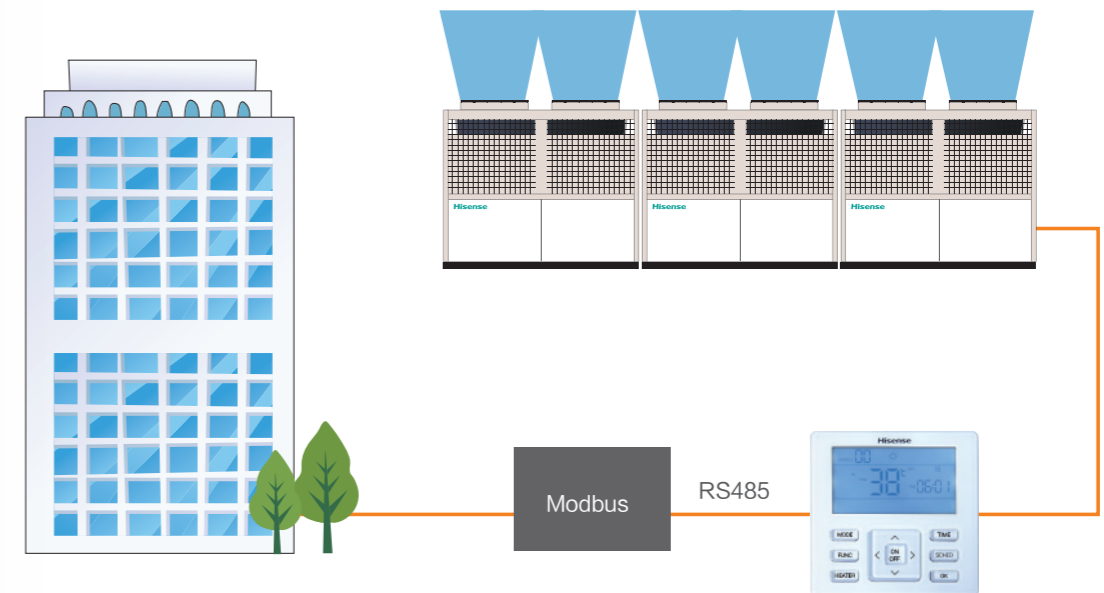



# Hi-Mod A Series

## Standard type

Hi-Mod A series can realize free combination between 16 modules, and the maximum combined capacity is 2080kW, which can be applied in large space.

- High Efficient Scroll Compressor  
Efficiency, reliability and strong capacity output
- Environment-friendly Refrigerant R410A



### High Energy Efficiency and Environment-friendly Refrigerant R410A

- COP as high as 3.39.
- Energy-saving, effectively reduces the operation cost.
- R410A environmentally friendly refrigerant is without any damage to the ozoneosphere.
- Meet the requirements of the RoHS directive for environmental protection, health and no-pollution.



### Efficient Scroll Compressor

Hi-Mod A series adopts the high efficient hermetic scroll compressor, ensuring an efficient, reliable and low noise operation. What's more, the scroll compressor has small vibration and long lifetime.

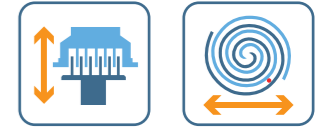

Optimized design of scroll plate and seal ring guarantee small leakage and thereby greatly increasing the volume efficiency.

The bearing capacity of main bearing seat is strengthened and the design is more stable and reliable.

The bottom bearing plate with 4 screws makes bearing more stable.

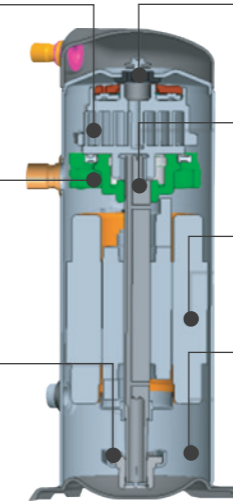

One-way discharge valve is built in, avoiding the backflow of refrigerant.

The bearing capacity of the drive bearing is enhanced to make operation more stable and reliable.

High-efficiency motor makes compressor more efficient and prolongs the compressor's lifetime.

Large oil tank can be precharged with more condensed oil to ensure that the compressor is lubricated reliably in all working conditions.

### Wide Operation Range

- Cooling operation temperature range: 15~48°C, Heating operation temperature range: -15~25°C.
- The cooled water outlet temperature is 5~15°C, while heated outlet temperature is 35~50°C. It can meet the comfort requirements of air conditioning in different seasons.

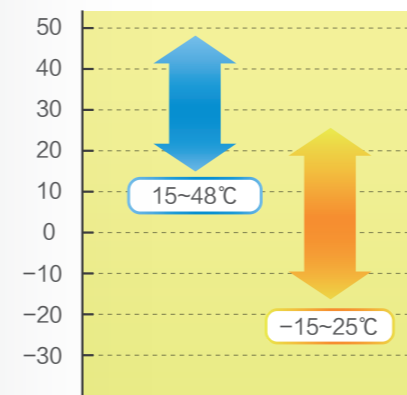

Cooling operation temperature  
Heating operation temperature

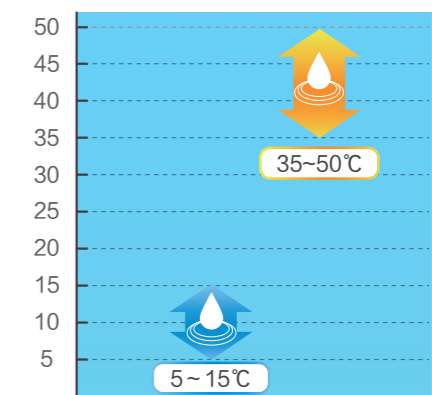

Water temp when cooling  
Water temp when heating



## Hi-Mod A Series (Standard type)

Model		HFRE-65W/A2F	HFRE-130W/A2F	
Cooling Capacity	kW	65.0	130.0	
Heating Capacity	kW	70.0	140.0	
Rated Power Input of Cooling	kW	19.2	38.5	
Cooling Current	A	40.0	81.5	
Rated Power Input of Heating	kW	21.0	42.0	
Rated Heating Current	A	42.5	83.5	
Max. Consumption Power	kW	30.2	60.4	
Max. Current	A	52.0	104.0	
Single Unit Capacity Regulation	—	0-50%-100%	0-25%-50%-75%-100%	
Power Supply	—	AC 3Φ, 380V/50Hz	AC 3Φ, 380V/50Hz	
Noise	dB(A)	68	78	
Water Flow	m³/h	11.2	22.4	
Water Resistance	kPa	45	50	
Water Inlet/Outlet Pipe Diameter	DN	DN65 Flange Connection	DN65 Flange Connection	
Max. Pressure Resistance of Water-side Heat Exchanger	MPa	1.0	1.0	
Running Mode	—	Automatic Operation Controlled By Microcomputer	Automatic Operation Controlled By Microcomputer	
Compressor Type	—	Hermetic Scroll Compressor	Hermetic Scroll Compressor	
Quantity of Compressors	PC	2	4	
Fan	Type	Axial Flow with Low-noise Large Blades		
	Air Volume	m³/h	26000	47000
	Quantity	PC	2	2
Refrigerant	Type	R410A		
	Precharged Amount	kg	2×6.0	2×11.5
Dimensions	Length	mm	2200	2300
	Width	mm	860	1100
	Height	mm	1910	2200
Weight	Net Weight	kg	620	1030
	Running Weight	kg	660	1130

### Combined Capacity Parameter List

Model	HFRE-65W/A2F	1	2	3	4	5	6	7	8	9	10	11	12	13	14	15	16
Cooling Capacity	kW	65	130	195	260	325	390	455	520	585	650	715	780	845	910	975	1040
Heating Capacity	kW	70	140	210	280	350	420	490	560	630	700	770	840	910	980	1050	1120
Water Flow	m³/h	11.2	22.4	33.6	44.8	56.0	67.2	78.4	89.6	100.8	112.0	123.2	134.4	145.6	156.8	168.0	179.2

Model	HFRE-130W/A2F	1	2	3	4	5	6	7	8	9	10	11	12	13	14	15	16
Cooling Capacity	kW	130	260	390	520	650	780	910	1040	1170	1300	1430	1560	1690	1820	1950	2080
Heating Capacity	kW	140	280	420	560	700	840	980	1120	1260	1400	1540	1680	1820	1960	2100	2240
Water Flow	m³/h	22.4	44.8	67.2	89.6	112.0	134.4	156.8	179.2	201.6	224.0	246.4	268.8	291.2	313.6	336.0	358.4

Note:

- Rated cooling capacity and heating capacity are tested in the following conditions:  
Cooling conditions: outdoor ambient temperature is 35°C DB, and water outlet temperature is 7°C under the rated water flow.  
Heating conditions: outdoor ambient temperature is 7°C DB/6°C WB, and water outlet temperature is 45°C under the rated water flow.
- During the actual application, 6% loss of the capacity should be considered due to the pipeline, water pumps, various valves, dirt and so on.
- Hi-Mod A series should not work at the temperature lower than 15°C when cooling and lower than -15°C when heating.
- The specifications subject to change without notice in accordance with our policy of continuous product improvement.
- The above noise values are measured in the anechoic chamber.

## Hi-Mod E Series

### Low Temperature and Strong Heating Type

Hi-Mod E series adopts advanced EVI compression technology, and further optimizes the system design, effectively improving the heating capacity and efficiency under low-temperature conditions, and the lowest ambient temperature for heating operation can be as low as -26°C. Also it can provide a wide range of hot water temperature, with the highest water temperature of 55°C, meeting the needs of heating and domestic hot water.

- ⊙ **EVI Compressor**  
Greatly improve the heating capacity and energy efficiency
- ⊙ **Environment-friendly Refrigerant R410A**



### EVI Compression Technology, Strong Heating Under Low Temperature

EVI compression technology overcomes the shortcomings of traditional air source heat pump units under low ambient temperature, such as capacity decreasing and low efficiency, greatly enhancing the low temperature heating capacity and improving the capacity and efficiency of the whole system.

- ⊙ Heating capacity is increased by 7%~20%.
- ⊙ The highest outlet water temperature is 55°C.



### High Energy Efficiency and Environment-friendly Refrigerant R410A

The system has great performance under low ambient temperature. The nominal heating efficiency can separately reach to 2.6 (HFRE-65W/E2F) and 2.52 (HFRE-130W/E2F). Meanwhile, it adopts environment-friendly refrigerant R410A, which is non-toxic to human and doesn't damage the earth's ozone layer.



### Wide Operation Range

- Cooling operation temperature range 15~48°C, heating operation temperature range: -26~25°C.
- The cooled water outlet temperature is 5~15°C, while heated outlet temperature is 35~55°C. It greatly satisfies the various requirements.

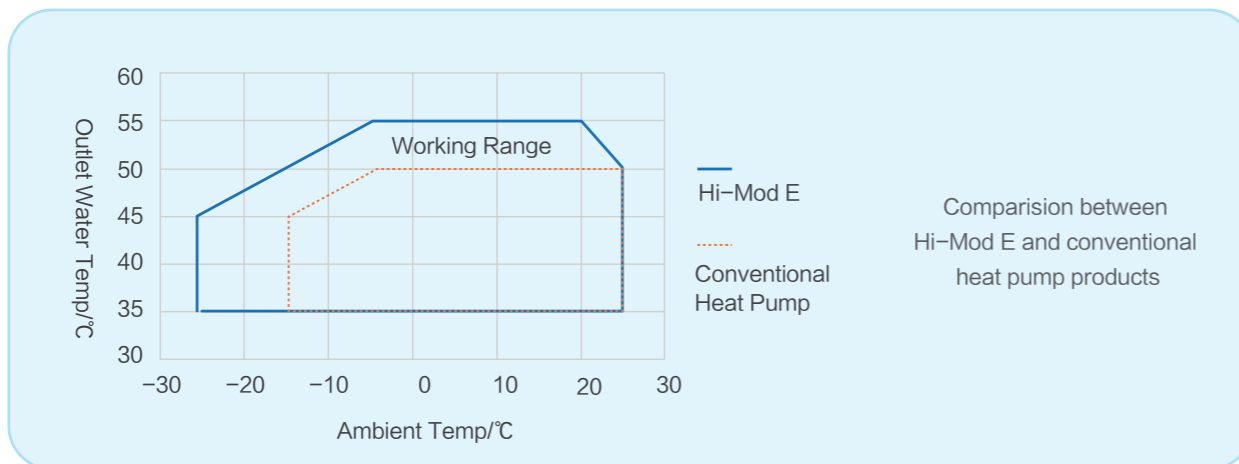
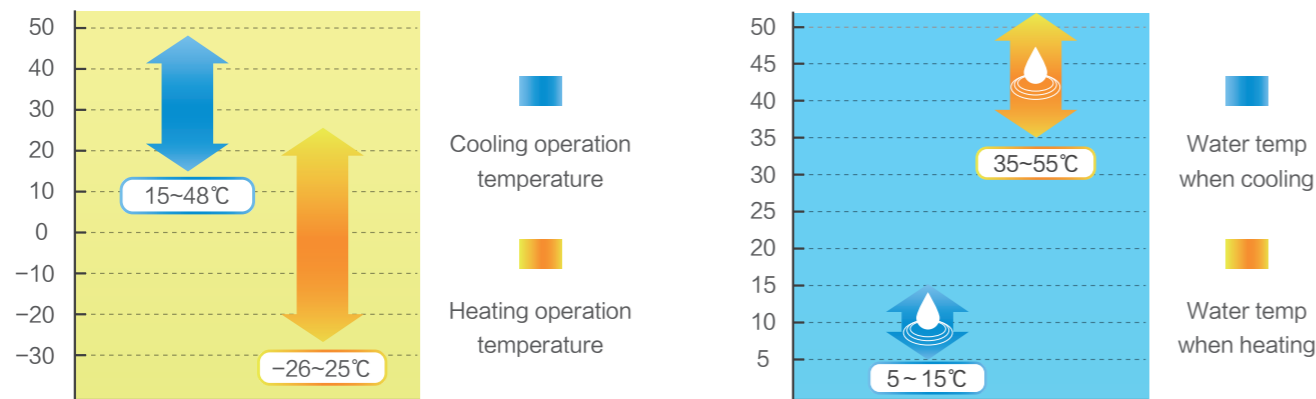

## Hi-Mod E Series (Low temperature and strong heating type)

Model		HFRE-65W/E2F	HFRE-130W/E2F	
Heating Capacity (7°C)	kW	70.0	140.0	
Power Input of Heating (7°C)	kW	19.6	39.6	
Heating Capacity (-12°C)	kW	45.0	90.0	
Power Input of Heating (-12°C)	kW	17.3	35.7	
Cooling Capacity	kW	65.0	130.0	
Power Input of Cooling	kW	19.0	38.1	
COPc/COPh (-12°C)	kW/kW	3.42/2.60	3.41/2.52	
Current of Heating (7°C)	A	42.0	84.5	
Current of Low Temp. Heating (-12°C)	A	36.9	76.0	
Current of Cooling	A	40.5	81.5	
Max. Power Consumption	kW	30.0	60.0	
Max. Current	A	52.0	104.0	
Single Unit Capacity Regulation	—	0-50%-100%	0-50%-100%	
Power Supply	—	AC 3Φ, 380V/50Hz	AC 3Φ, 380V/50Hz	
Noise	dB(A)	68	78	
Water Flow	m³/h	11.2	22.4	
Water Resistance	kPa	50	50	
Water Inlet/Outlet Pipe Diameter	DN	DN65 Flange Connection	DN65 Flange Connection	
Max. Pressure Resistance of Water-side Heat Exchanger	MPa	1.0	1.0	
Running Mode	—	Automatic Operation Controlled By Microcomputer	Automatic Operation Controlled By Microcomputer	
Compressor Type	—	Hermetic Scroll Compressor	Hermetic Scroll Compressor	
Quantity of Compressors	PC	2	2	
Fan	Type	Axial Flow with Low-noise Large Blades		
	Air Volume	m³/h	26000	47000
	Quantity	PC	2	2
Refrigerant	Type	R410A		
	Precharged Amount	kg	2 × 7.0	2 × 10.5
Dimensions	Length	mm	2200	2300
	Width	mm	860	1100
	Height	mm	1910	2200
Weight	Net Weight	kg	665	1030
	Running Weight	kg	710	1130

### Combined Capacity Parameter List

Model	HFRE-65W/E2F	1	2	3	4	5	6	7	8	9	10	11	12	13	14	15	16
Cooling Capacity	kW	65	130	195	260	325	390	455	520	585	650	715	780	845	910	975	1040
Heating Capacity*	kW	70	140	210	280	350	420	490	560	630	700	770	840	910	980	1050	1120
Water Flow	m³/h	11.2	22.4	33.6	44.8	56.0	67.2	78.4	89.6	100.8	112.0	123.2	134.4	145.6	156.8	168.0	179.2

Model	HFRE-130W/E2F	1	2	3	4	5	6	7	8	9	10	11	12	13	14	15	16
Cooling Capacity	kW	130	260	390	520	650	780	910	1040	1170	1300	1430	1560	1690	1820	1950	2080
Heating Capacity*	kW	140	280	420	560	700	840	980	1120	1260	1400	1540	1680	1820	1960	2100	2240
Water Flow	m³/h	22.4	44.8	67.2	89.6	112.0	134.4	156.8	179.2	201.6	224.0	246.4	268.8	291.2	313.6	336.0	358.4

Note:

- Rated cooling capacity and heating capacity are tested in the following conditions:  
Cooling conditions: outdoor ambient temperature is 35°C DB, and water outlet temperature is 7°C under the rated water flow.  
Heating conditions (7°C): outdoor ambient temperature is 7°C DB/6°C WB, and water outlet temperature is 45°C under the rated water flow.  
Heating conditions (-12°C): outdoor ambient temperature is -12°C DB/-14°C WB, and water outlet temperature is 41°C under the rated water flow.
- During the actual application, 6% loss of the capacity should be considered due to the pipeline, water pumps, various valves, dirt and so on.
- Hi-Mod E series should not work at the temperature lower than 15°C when cooling and lower than -26°C when heating.
- The specifications subject to change without notice in accordance with our policy of continuous product improvement.
- The heat capacity noted with\* is tested when outdoor ambient temperature is 7°C DB/6°C WB, and water outlet temperature is 45°C under the rated water flow.



# Hi-Mod H Series

## Ultra-low Temperature and Strong Heating Type

The highest outlet water temperature as high as 60°C, which better meets the water temp. demand of heat radiator. Meanwhile, it has strong heating capacity under very extremely ambient temperature as low as -26°C, and the COP under heating operation exceeds 2.0 at -20°C, more efficient. Thus, Hi-Mod H series can be widely applied in extremely cold districts.

- Ultra low temperature and strong heating  
Strong capacity under extreme low ambient temperature  
Outlet water temperature as high as 60°C
- EVI Compressor  
Efficiency and reliable



### Excellent Heating Capacity at Low Temperature

- Under the ambient temp -12°C, the heating capacity with 41°C hot water outlet can reach more than 62.5% of the rated heating capacity.
- Under the ambient temp -20°C, when the temp of hot water outlet is 45°C, the COP of the system can exceed 2.0.
- Compared with the conventional R410A units on the market, Hi-Mod H series can increase the heat capacity as high as 15% at ultra low temperature.

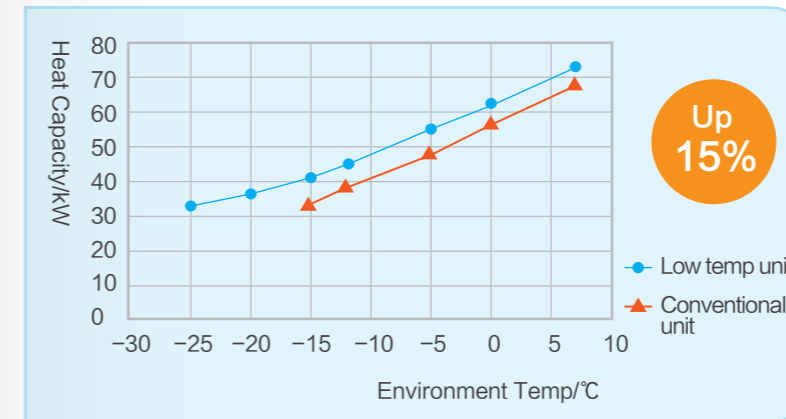

### Wide Operation Range for Broad Applications

- Heating operation temperature range: -26~25°C, cooling operation temperature range: 15~48°C.
- The heated water outlet temperature is 35~60°C, and the cooled water outlet temperature is 5~15°C.
- With wide range of water temperature, it covers hot water temperature needs of the old cast iron radiator, new copper and aluminum composite radiator, fan coil, floor heating and other heating equipments.

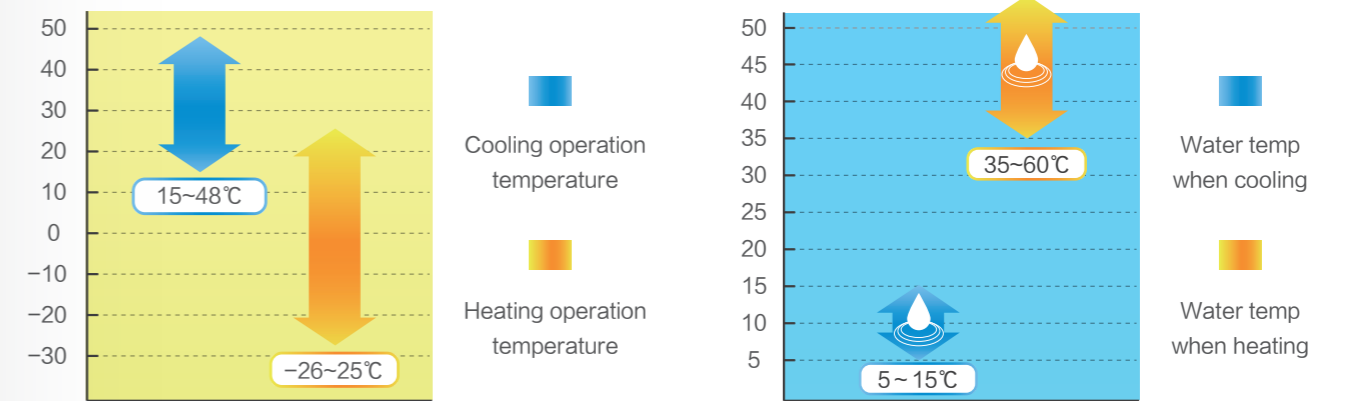

Old Type Radiator  
(Hot water 50~65°C)



New Type Radiator  
(Hot water 45~55°C)

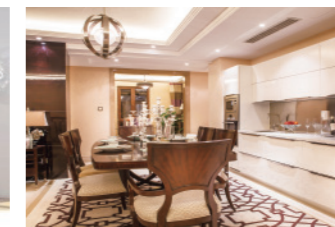

Fan Coil  
(Hot water 40~50°C)



Floor Heating  
(Hot water 35~45°C)



# Hi-Mod H Series (Ultra-low temperature and strong heating type)

Model		HFRE-70W/H1F	HFRE-150W/H1F
Heating Capacity (7°C)	kW	72.0	161.0
Power Input of Heating (7°C)	kW	21.0	45.1
Heating Capacity (-12°C)	kW	45.0	104.0
Power Input of Heating (-12°C)	kW	18.0	41.6
Cooling Capacity	kW	66.0	150.0
Power Input of Cooling	kW	19.8	45.2
Current of Heating	A	42.5	89.6
Current of Low Temp. Heating	A	36.5	82.8
Current of Cooling	A	41.0	90.0
Max. Power Consumption	kW	30.0	66.0
Max. Current	A	54.0	116.0
Single Unit Capacity Regulation	—	0-50%-100%	0-50%-100%
Power Supply	—	AC 3Φ, 380V/50Hz	AC 3Φ, 380V/50Hz
Noise	dB(A)	68	76
Water Flow	m³/h	11.35	25.80
Water Resistance	kPa	50	50
Water Inlet/Outlet Pipe Diameter	DN	DN65 Flange Connection	DN65 Flange Connection
Max. Pressure Resistance of Water-side Heat Exchanger	MPa	1.0	1.0
Running Mode	—	Automatic Operation Controlled By Microcomputer	Automatic Operation Controlled By Microcomputer
Compressor Type	—	Hermetic Scroll Compressor	Hermetic Scroll Compressor
Quantity of Compressors	PC	2	2
Fan	Type	—	Axial Flow with Low-noise Large Blades
	Air Volume	m³/h	26000
	Quantity	PC	2
Refrigerant	Type	—	R410A
	Precharged Amount	kg	2 × 8.5
Dimensions	Length	mm	2200
	Width	mm	860
	Height	mm	2010
Weight	Net Weight	kg	710
	Running Weight	kg	760

## Combined Capacity Parameter List

Model	HFRE-70W/H1F	1	2	3	4	5	6	7	8	9	10	11	12	13	14	15	16
Cooling Capacity	kW	66	132	198	264	330	396	462	528	594	660	726	792	858	924	990	1056
Heating Capacity*	kW	72	144	216	288	360	432	504	576	648	720	792	864	936	1008	1080	1152
Water Flow	m³/h	11.36	22.72	34.08	45.44	56.80	68.16	79.52	90.88	102.24	113.60	124.96	136.32	147.68	159.04	170.40	181.76

Model	HFRE-150W/H1F	1	2	3	4	5	6	7	8	9	10	11	12	13	14	15	16
Cooling Capacity	kW	150	300	450	600	750	900	1050	1200	1350	1500	1650	1800	1950	2100	2250	2400
Heating Capacity*	kW	161	322	483	644	805	966	1127	1288	1449	1610	1771	1932	2093	2254	2415	2576
Water Flow	m³/h	25.8	51.6	77.4	103.2	129.0	154.8	180.6	206.4	232.2	258.0	283.8	309.6	335.4	361.2	387.0	412.8

- Note:
- Rated cooling capacity and heating capacity are tested in the following conditions:  
Cooling conditions: outdoor ambient temperature is 35°C DB, and water outlet temperature is 7°C under the rated water flow.  
Heating conditions (7°C): outdoor ambient temperature is 7°C DB/6°C WB, and water outlet temperature is 45°C under the rated water flow.  
Heating conditions (-12°C): outdoor ambient temperature is -12°C DB/-14°C WB, and water outlet temperature is 41°C under the rated water flow.
  - During the actual application, 6% loss of the capacity should be considered due to the pipeline, water pumps, various valves, dirt and so on.
  - Hi-Mod H series should not work at the temperature lower than 15°C when cooling and lower than -26°C when heating.
  - The specifications subject to change without notice in accordance with our policy of continuous product improvement.
  - The heat capacity noted with\* is tested when outdoor ambient temperature is 7°C DB/6°C WB, and water outlet temperature is 45°C under the rated water flow.

## Capacity Correction Factor

### Correction factors of cooling performance

Water Outlet Temperature °C	Environment Temperature °C											
	20		25		30		35		40		45	
	Cooling Capacity	Power Input	Cooling Capacity	Power Input	Cooling Capacity	Power Input	Cooling Capacity	Power Input	Cooling Capacity	Power Input	Cooling Capacity	Power Input
5	1.113	0.776	1.056	0.858	1.000	0.928	0.943	0.990	0.868	1.069	0.792	1.135
7	1.180	0.783	1.120	0.867	1.060	0.938	1.000	1.000	0.920	1.080	0.840	1.147
9	1.254	0.791	1.191	0.875	1.127	0.947	1.063	1.010	0.978	1.091	0.893	1.158
11	1.337	0.799	1.269	0.884	1.201	0.956	1.133	1.020	1.042	1.102	0.952	1.170
13	1.410	0.807	1.338	0.893	1.267	0.966	1.195	1.030	1.099	1.112	1.004	1.181
15	1.475	0.815	1.400	0.901	1.325	0.975	1.250	1.040	1.150	1.123	1.050	1.193

Note: The above correction factors are applied for these models: HFRE-65W/A2F, HFRE-130W/A2F, HFRE-65W/E2F, HFRE-130W/E2F, HFRE-70W/H1F, HFRE-150W/H1F.

### Correction factors of heating performance

Water Outlet Temperature °C	Environment Temperature °C													
	-15		-10		-5		0		7		15		21	
	Heating Capacity	Power Input	Heating Capacity	Power Input	Heating Capacity	Power Input	Heating Capacity	Power Input	Heating Capacity	Power Input	Heating Capacity	Power Input	Heating Capacity	Power Input
35	0.546	0.802	0.642	0.818	0.749	0.834	0.870	0.850	1.070	0.890	1.220	0.930	1.284	0.954
40	0.525	0.836	0.618	0.862	0.721	0.888	0.838	0.910	1.030	0.950	1.174	0.990	1.236	1.014
45	0.510	0.900	0.600	0.919	0.700	0.938	0.814	0.960	1.000	1.000	1.140	1.043	1.200	1.074
50	—	—	0.582	0.983	0.679	1.003	0.790	1.025	0.970	1.055	1.106	1.105	1.164	1.134

Note: The above correction factors are applied for these models: HFRE-65W/A2F, HFRE-130W/A2F.

Water Outlet Temperature °C	Environment Temperature °C																	
	-25		-20		-15		-12		-5		0		7		15		21	
	Heating Capacity	Power Input	Heating Capacity	Power Input	Heating Capacity	Power Input	Heating Capacity	Power Input	Heating Capacity	Power Input	Heating Capacity	Power Input	Heating Capacity	Power Input	Heating Capacity	Power Input	Heating Capacity	Power Input
35	0.477	0.821	0.538	0.826	0.612	0.832	0.664	0.835	0.793	0.851	0.886	0.860	1.060	0.886	1.197	0.913	1.297	0.937
40	0.464	0.851	0.524	0.859	0.595	0.867	0.646	0.871	0.771	0.894	0.861	0.907	1.030	0.939	1.163	0.966	1.260	0.989
45	0.451	0.905	0.511	0.914	0.582	0.923	0.632	0.929	0.752	0.952	0.838	0.966	1.000	1.000	1.129	1.026	1.222	1.049
50	—	—	—	—	0.563	1.001	0.611	1.008	0.726	1.025	0.809	1.034	0.965	1.060	1.089	1.086	1.179	1.108
55	—	—	—	—	—	—	—	—	0.703	1.086	0.781	1.094	0.930	1.119	1.049	1.143	1.136	1.164

Note: The above correction factors are applied for HFRE-65W/E2F.

Water Outlet Temperature °C	Environment Temperature °C																	
	-25		-20		-15		-12		-5		0		7		15		21	
	Heating Capacity	Power Input	Heating Capacity	Power Input	Heating Capacity	Power Input	Heating Capacity	Power Input	Heating Capacity	Power Input	Heating Capacity	Power Input	Heating Capacity	Power Input	Heating Capacity	Power Input	Heating Capacity	Power Input
35	0.477	0.831	0.538	0.837	0.612	0.847	0.664	0.853	0.793	0.861	0.886	0.870	1.060	0.886	1.197	0.919	1.297	0.943
40	0.464	0.862	0.524	0.870	0.595	0.882	0.646	0.890	0.771	0.904	0.861	0.917	1.030	0.939	1.163	0.972	1.260	0.995
45	0.451	0.917	0.511	0.926	0.582	0.940	0.632	0.948	0.752	0.963	0.838	0.977	1.000	1.000	1.129	1.032	1.222	1.055
50	—	—	—	—	0.563	1.019	0.611	1.029	0.726	1.038	0.809	1.047	0.965	1.060	1.089	1.094	1.179	1.117
55	—	—	—	—	—	—	—	—	0.703	1.100	0.781	1.108	0.930	1.119	1.049	1.152	1.136	1.173

Note: The above correction factors are applied for HFRE-130W/E2F.



Water Outlet Temperature °C	Environment Temperature °C																	
	-25		-20		-15		-12		-5		0		7		15		21	
	Heating Capacity	Power Input	Heating Capacity	Power Input	Heating Capacity	Power Input	Heating Capacity	Power Input	Heating Capacity	Power Input	Heating Capacity	Power Input	Heating Capacity	Power Input	Heating Capacity	Power Input	Heating Capacity	Power Input
35	0.466	0.788	0.536	0.798	0.605	0.809	0.647	0.815	0.783	0.841	0.886	0.860	1.060	0.886	1.219	0.924	1.325	0.953
40	0.453	0.818	0.521	0.831	0.588	0.844	0.628	0.851	0.761	0.884	0.861	0.907	1.030	0.939	1.185	0.977	1.288	1.005
45	0.440	0.872	0.507	0.886	0.575	0.900	0.615	0.909	0.742	0.942	0.838	0.966	1.000	1.000	1.150	1.037	1.250	1.065
50	0.425	0.945	0.490	0.962	0.555	0.978	0.593	0.988	0.716	1.015	0.809	1.034	0.965	1.060	1.110	1.097	1.206	1.124
55	—	—	0.474	1.029	0.538	1.043	0.577	1.052	0.693	1.076	0.781	1.094	0.930	1.119	1.070	1.154	1.163	1.180
60	—	—	—	—	0.515	1.101	0.552	1.106	0.663	1.138	0.747	1.160	0.890	1.192	1.024	1.226	1.113	1.252

Note: The above correction factors are applied for HFRE-70W/H1F.

Water Outlet Temperature °C	Environment Temperature °C																	
	-25		-20		-15		-12		-5		0		7		15		21	
	Heating Capacity	Power Input	Heating Capacity	Power Input	Heating Capacity	Power Input	Heating Capacity	Power Input	Heating Capacity	Power Input	Heating Capacity	Power Input	Heating Capacity	Power Input	Heating Capacity	Power Input	Heating Capacity	Power Input
35	0.472	0.831	0.528	0.837	0.612	0.855	0.667	0.869	0.793	0.876	0.886	0.885	1.060	0.893	1.197	0.919	1.297	0.943
40	0.460	0.862	0.514	0.870	0.595	0.892	0.649	0.910	0.771	0.919	0.861	0.927	1.030	0.939	1.163	0.972	1.260	0.995
45	0.446	0.917	0.501	0.926	0.582	0.950	0.635	0.968	0.752	0.978	0.838	0.987	1.000	1.000	1.129	1.032	1.222	1.055
50	—	—	0.488	0.982	0.563	1.010	0.614	1.033	0.726	1.044	0.809	1.051	0.965	1.063	1.089	1.094	1.179	1.117
55	—	—	—	—	0.543	1.069	0.593	1.098	0.703	1.108	0.781	1.118	0.930	1.127	1.049	1.152	1.136	1.173
60	—	—	—	—	—	—	—	—	0.680	1.172	0.753	1.179	0.895	1.186	1.009	1.209	—	—

Note: The above correction factors are applied for HFRE-150W/H1F.

Unit Dimensions

- HFRE-65W/A2F
- HFRE-65W/E2F

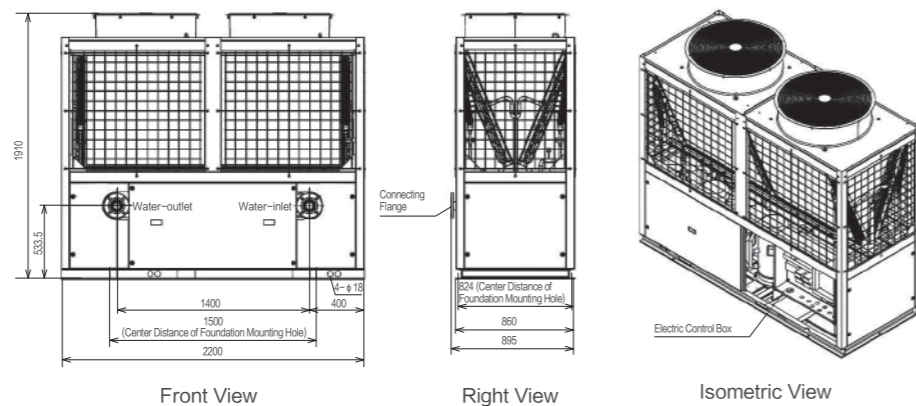

- HFRE-150W/H1F

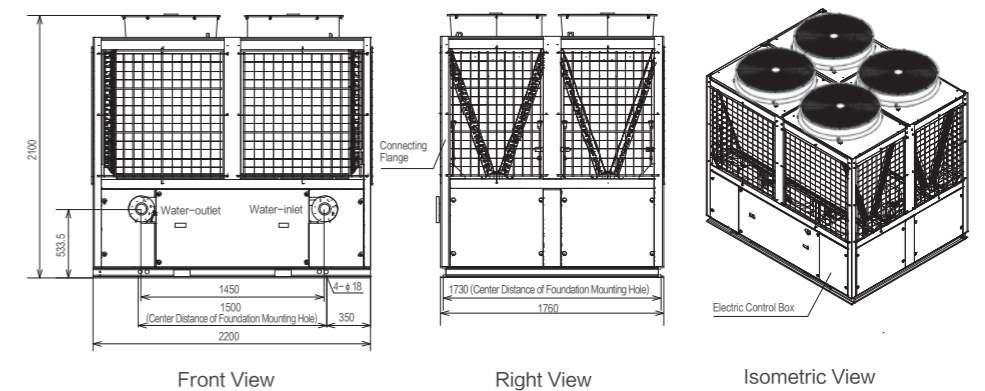

- HFRE-130W/A2F
- HFRE-130W/E2F

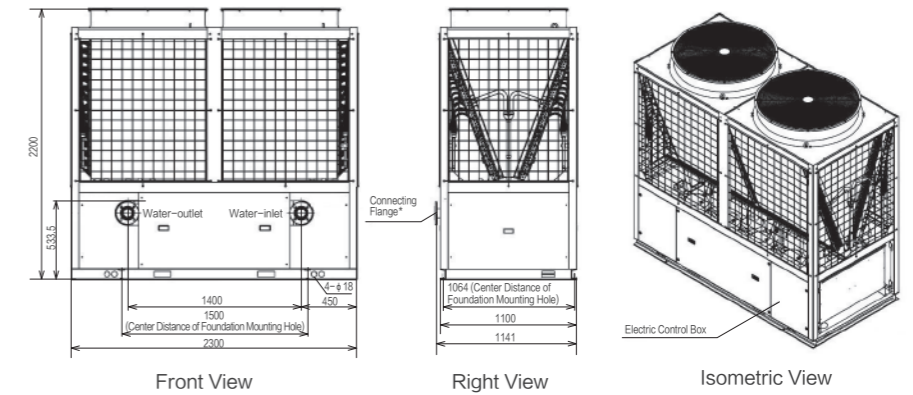

Note: \* The picture shows the connection flange position for E series, while for the A series, the connection flange doesn't extend beyond the frame.

- HFRE-70W/H1F

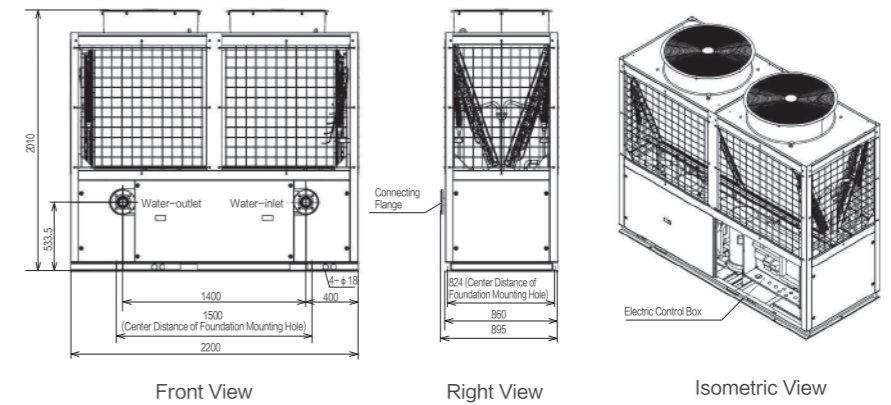



Installation Demand

- HFRE-65W/A2F, HFRE-65W/E2F, HFRE-70W/H1F

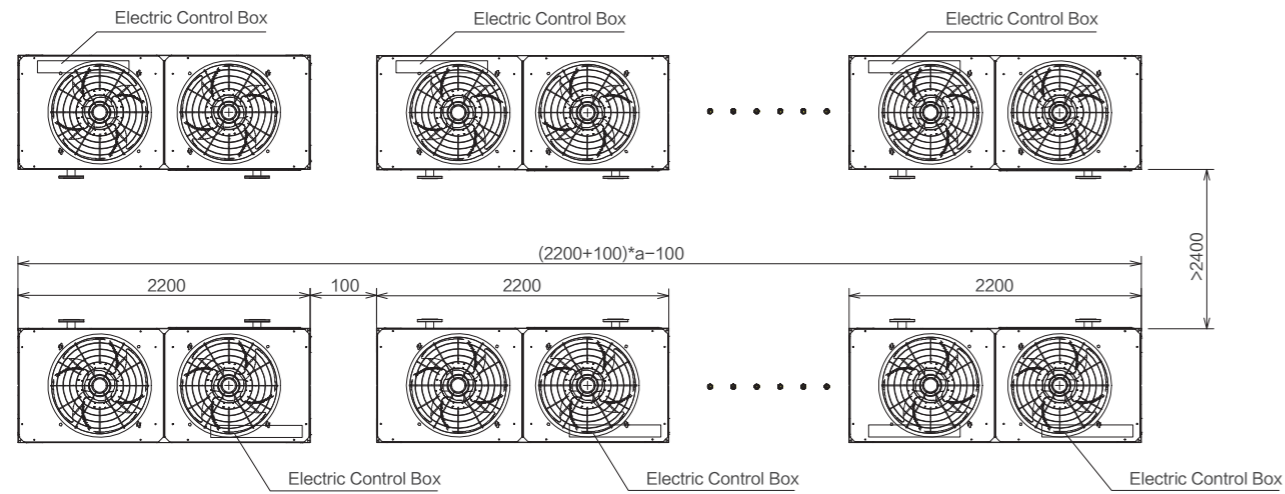

- HFRE-130W/A2F, HFRE-130W/E2F

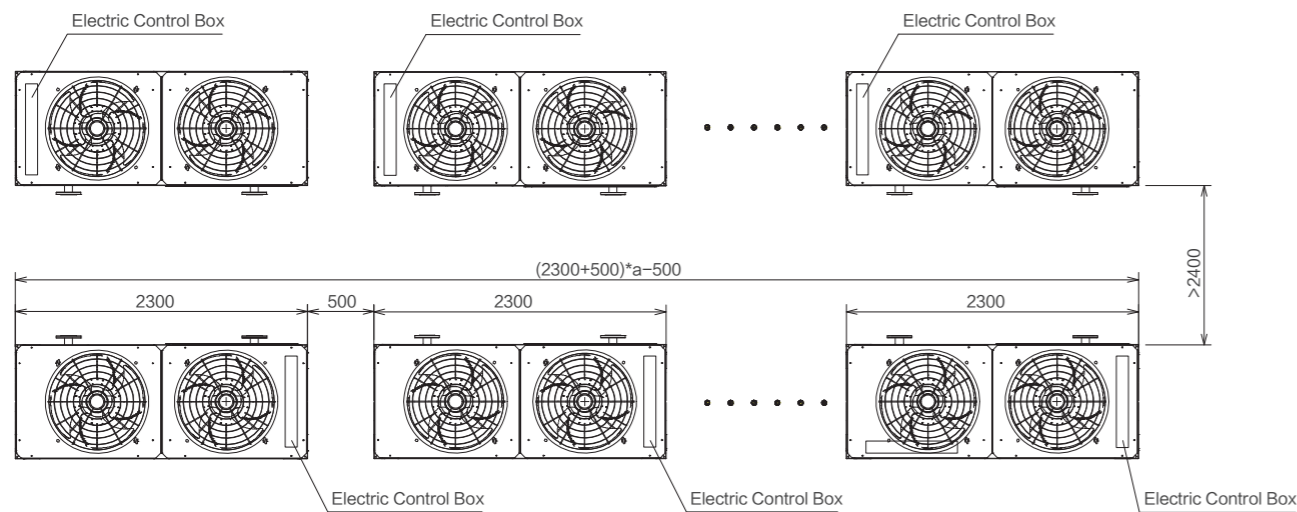

- HFRE-150W/H1F

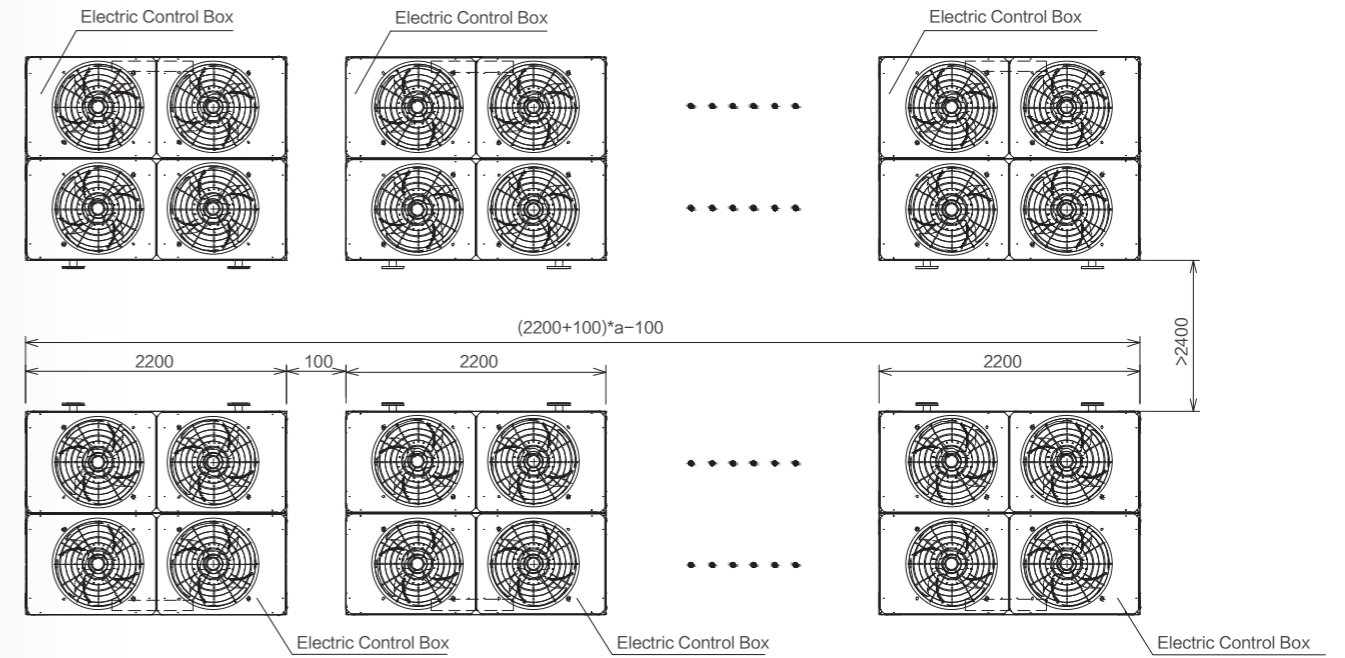

Note: The letter "a" means the quantity of modules.



# Hi-Mod V Series

## Air-cooled Modular Chiller

Hisense Hi-Mod V series air-cooled modular chiller uses energy-efficient scroll compressors, R410A environmentally friendly refrigerants, high-efficiency shell-and-tube heat exchangers, and AI defrosting technology, as well as cutting-edge microcomputer control technology, which brings users an excellent sense of experience, and achieves cooling in summer and heating in winter. Therefore, it is the first choice for the central air-conditioning systems for high-end hotels, office buildings, schools, hospitals, factories and enterprises, and many various large-and medium-sized public buildings and civil buildings.



### Wide operation range

Hi-Mod V series has undergone a series of strict tests before launching, such as corrosion resistance test, fatigue test, frequent start and stop test and so on. After these rigorous long-term tests, the unit can operate stably in wide operation range, from 5°C to 48°C under cooling, and from -15°C to 30°C under heating.

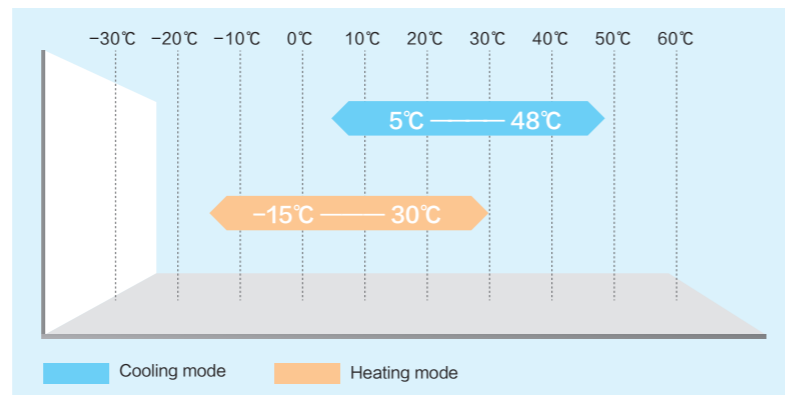

### Accurate temperature control

Quality grade-500 PMV electronic pulse is adopted for precise adjustment, to realize the precise PID control of electronic expansion valve, realtime dynamic matching, and higher precision of water temperature control.

throttle apparatus (electronic expansion valve)



- Electronic servo throttling
- Wide-range adjusting ability
- Dynamic superheat degree adjusting
- Strong adaptability to working conditions
- Adapting to any flow regulation

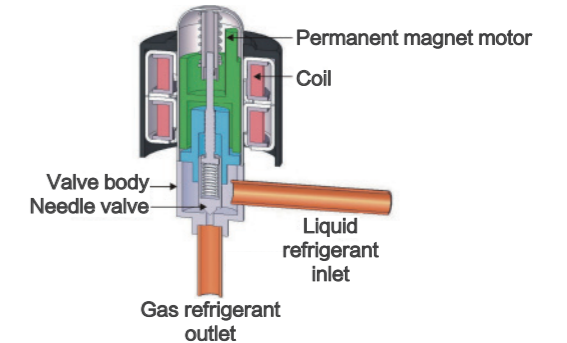

### Anti-freezing and defrosting

#### Four-step anti-freezing protection in winter

The unit are equipped with water pump linkage control for anti-freezing, temperature sensor linkage protection, pressure sensor linkage protection, and anti-freezing protection under heating.

#### Suspending finned heat exchanger

This can prevent the accumulation of rain and snow during the heating operation, and avoid condensed water freezing at the bottom of the heat exchanger during the defrost mode.

#### Centralized drainage

The drain pan with high drainage capacity is conducive to smooth drainage of condensed water during defrosting.

#### Thermal radiation anti-frosting design

A unique heat radiation anti-frosting device is equipped in the last refrigerant circuit at the bottom of the heat exchanger. When defrosting, high-temperature refrigerant is introduced into the bottom to effectively prevent the bottom from freezing.

#### Anti-snow function

The unit is featured with anti-snow function, so the unit can not be covered by the heavy snow when working.





### Alternate defrost

The multiple systems in one single unit are independent of each other. When heating, the systems can realize intelligent alternate defrost according to their own frosting conditions. When one system is defrosting, the rest can be heating normally to avoid large fluctuations of water temperature during defrosting. During the intelligent defrost mode, the total quantity of compressors under defrost is less than 50%, so as to ensure stable heating requirements.

### Convenient and intelligent control with multiple protections

- The unit adopts microcomputer control system, and is standard with a touch LCD controller, easy to operate. Also, the optional RS485 interface and built-in Modbus protocol can realize centralized control.
- The unit has 13 built-in powerful protection functions, which provide comprehensive protections for the unit, including compressor low/high pressure protection, power supply phase loss and reverse protection, frequent start protection, compressor overcurrent protection, compressor discharge temperature protection, unit overheating protection, sensor failure protection, refrigeration anti-freeze protection, winter water system anti-freeze protection, insufficient water flow protection and so on.

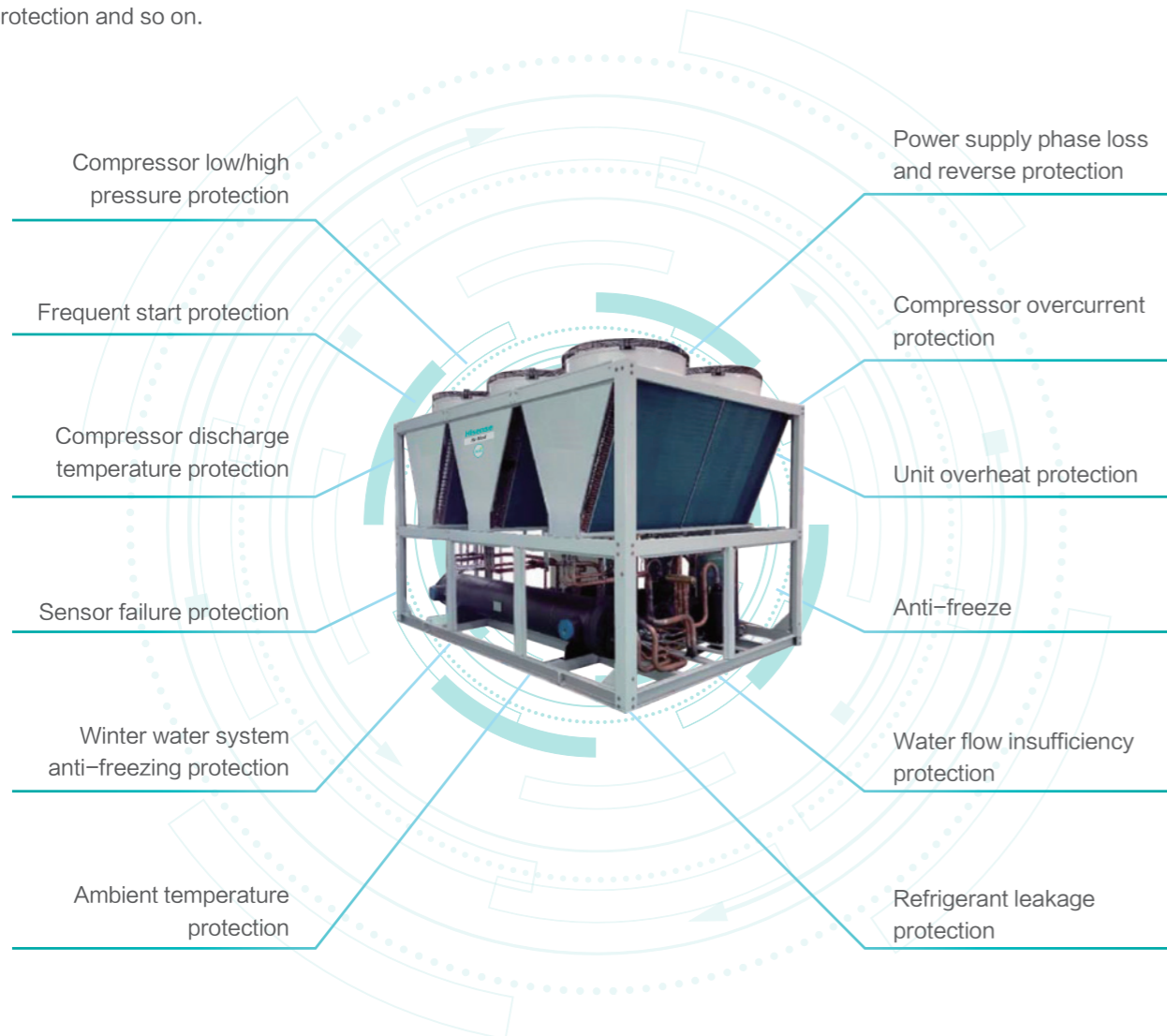

### Unit control function

#### Parameter setting function

- Time setting
- Timed ON/OFF for one week
- Cooling water inlet/outlet temp.
- Heating water inlet/outlet temp.
- Anti-freezing temp. and defrost temp.

#### Defrosting function

- Auto defrosting
- Manual defrosting

#### Memory function

- Memory function in case of power off
- Permanent storage for user parameters

#### Master/slave integration

- Any slave module can be used interchangeably as a master module
- Each system can be combined with 16 modules

#### Parameter display function

- Display of unit operating status
- Set water inlet and outlet temperature, actual water inlet and outlet temperature
- Timed adjustment, anti-freezing temp
- Anti-freezing temp in winter, defrosting temp

#### Other functions

- Fault diagnosis function
- Historical fault query
- Compressor average wear and module working time balance
- Water system two-way valve control function
- Auxiliary electric heating control function
- Remote ON/OFF control function within a maximum of 1 000 meters
- Start/stop control for chilled water pump
- Pump protection feedback
- Terminal two-way valve interlock control

### High-efficiency air-side heat exchanger

The V-shaped air-side heat exchanger of the unit conforms to the characteristics of airflow distribution, provides the largest windward area of the coil, and has the characteristics of good ventilation performance, large heat exchange area and strong corrosion resistance.

The heat exchanger adopts window-type hydrophilic aluminum fins and high-efficiency internally threaded copper tubes to enhance the heat exchange effect and improve the heat exchange efficiency.

The new Venturi separator is used in the fin condenser, and the refrigerant is evenly distributed to reduce pressure loss, reduce noise, and effectively improve heat exchange efficiency.

The surroundings are fixed by a reinforced metal frame to ensure higher firmness and higher stability and allow the entire unit structure to have a larger maintenance and repair space and flexible layout by saving the floor space by 30%.

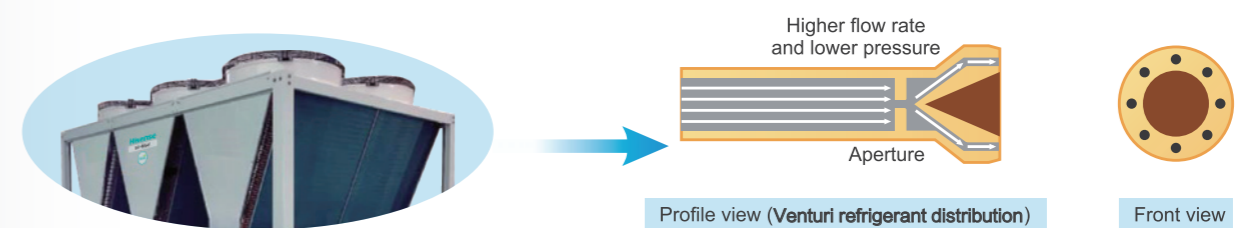

### High-efficiency scroll compressor with stable operation

Adopt international well-known high-efficiency scroll compressor which adopts international leading technologies, and radial flexible and axial flexible scroll compression technology, and add compressor crankcase heater design to prevent high starting resistance of the compressor due to excessive viscosity of lubricating oil. Multiple safe overload protections ensure stable, efficient and reliable operation.

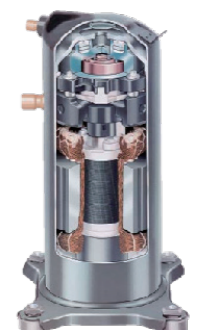



### Energy-efficient water-side heat exchanger

- The new shell-and-tube heat exchanger adopts a spiral heat exchange structure which has a spiral baffle with sealing edge inside, to reduce water resistance and enhance heat exchange capacity.
- The high-efficiency inner-threaded heat exchange tube effectively enhances the heat exchange effect. The refrigerant inlet area adopts inner-threaded heat exchange tube to realize better refrigerant distribution and heat exchange, with the efficiency 10% higher than that of conventional shell-and-tube heat exchangers.



### Large temperature difference design

Compared with conventional air-cooled chillers, Hisense large temperature difference system can achieve cold water temperature difference of 8 ~ 10 °C. With the increase of cold water temperature difference, the cold water volume, water pipe diameter and water pump capacity will be reduced, and the initial investment and operation cost will be reduced by 5% ~ 10%.

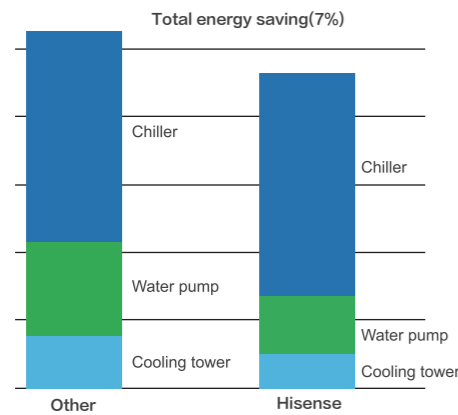

Conventional chiller VS Hisense large ΔT chiller

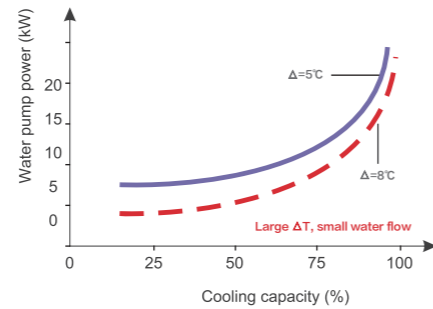

Energy saving for pump at part load conditions

### Eco-friendly R410A Refrigerant

- With the environmentally friendly refrigerant R410A which contains no chlorine and has an Ozone Depletion Potential (ODP) of 0, Hi-Mod V series will not damage the ozone layer.
- Under the same cooling conditions, the charge volume is smaller, which effectively improves the cooling efficiency and reduces the unit weight.

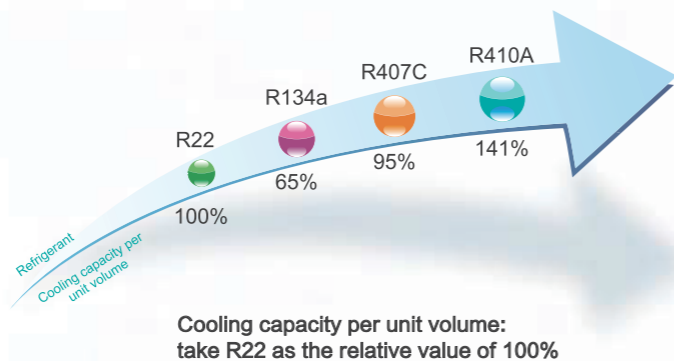

### Constant water temperature for enhanced comfort

- The chilled water outlet temperature is controlled accurately to  $\pm 1^\circ\text{C}$ . And various sensors are built in the system to accurately transmit the signal data to the controller, so as to ensure more reliable operation and optimal efficiency of the unit.
- The unit is equipped with standard outlet water temperature control, with constant water temperature, ensuring more accurate end temperature regulation and the best user experience. Also the optional return water temperature control to ensure the dynamic balance of the end users.

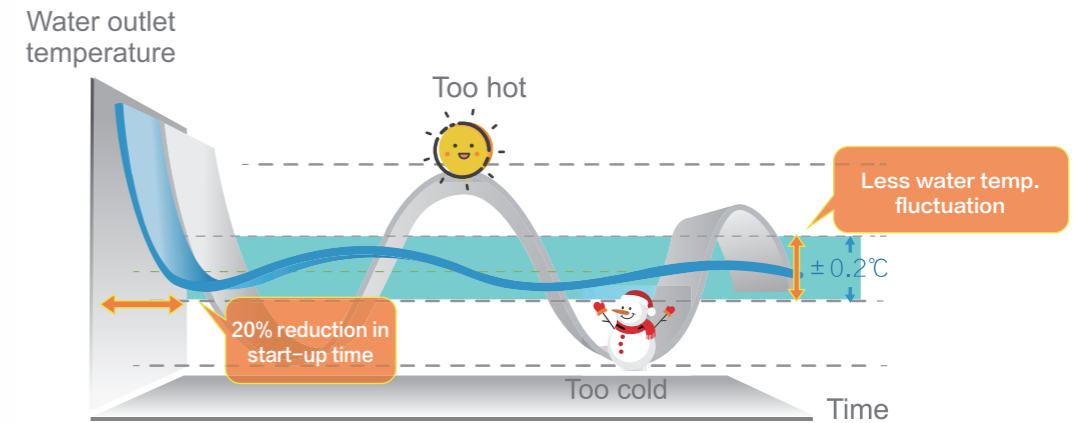

### Noise reduction design for quiet operation

- Overall vibration isolation: Quality low-noise and fully enclosed scroll compressor and low-noise fan are adopted. Through noise spectrum analysis, it carries out strict comparison, selection and improvement of fans, motors and other components, and performs professional noise reduction on the structure and pipelines, to effectively reduce the vibration of the key nodes of the pipelines through elastic fixing parts, and systematically optimize the direction of the copper pipes.
- Innovative intelligent silent mode: Automatically adjust the number of working fans according to the operating status and the outdoor ambient temperature, easily achieving low-noise operation (the noise reduced by 6dB(A)).



Intelligent silence

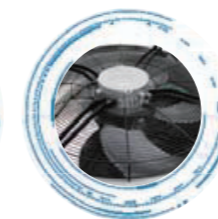

Low-noise motor

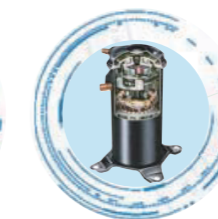

Low-noise and enclosed compressor

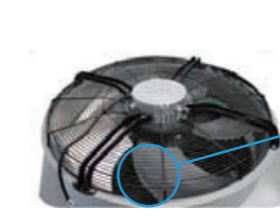

Low-noise airfoil fan

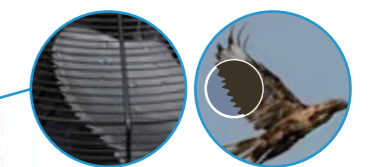

### Intelligent control

- Max. 16 units under control
- Powerful historical operation data storage
- Alarm code display
- Easy access to operation parameters
- 4 timer-settings per day





# Hi-Mod V Series ( Air-cooled Modular Chiller )

Model			HFRWE-345TGF/AE
Cooling	Capacity	kW	345
	Power input	kW	104
	Running current	A	178.3
Heating	Capacity	kW	355
	Power input	kW	105
	Running current	A	179.8
Max. power input		kW	142.6
Max. running current		A	246.4
Single unit capacity regulation			33.33%-66.67%-100%
EER			3.32
Power supply			380V/3N ~ /50Hz
Refrigerant	Type		R410A
	Precharge amount	kg	23×3
Throttling parts			Electronic expansion valve
Compressor	Type		Fully enclosed scroll compressor
	Lubricant		Ester oil (POE)
	Qty		3
Water-side heat exchanger	Type		Shell-and-tube
	Cooling water flow	m³/h	59.3
	Heating water flow	m³/h	61.1
	Water resistance	kPa	55
Inlet/outlet water pipe			DN125
Recommended inlet/outlet water pipe			DN125
Max. pressure resistance of water-side heat exchanger		kPa	60
Fan	Type		Axial propeller low-noise fan
	Air volume	m³/h	23500×6
	Qty		6
Net weight		kg	2520
Operating weight		kg	2650
Unit dimensions	Length	mm	3525
	Width	mm	2265
	Height	mm	2425
Controller model			HSXE-FB01M

Note:

- Working conditions for nominal cooling capacity: outlet water temperature 7°C; water flow 0.172m³/(h · kW); outdoor ambient temperature 35°C.
- Working conditions for nominal heating capacity: outlet water temperature 45°C; water flow 0.172 m³/(h · kW); outdoor temperature 7°C DB / 6°C WB.
- Water resistance excludes water pressure drop of the unit and the attached Y-shaped filter.
- A maximum of 16 units can be connected to form a modular combination.
- Specifications are subject to change due to design variations without further notice.

## Capacity correction table

### Cooling capacity

Model	Water outlet temperature (°C)	Ambient temperature (°C)															
		48°C		45°C		40°C		35°C		30°C		25°C		20°C		15°C	
		Cooling capacity kW	Power input kW	Cooling capacity kW	Power input kW	Cooling capacity kW	Power input kW	Cooling capacity kW	Power input kW	Cooling capacity kW	Power input kW	Cooling capacity kW	Power input kW	Cooling capacity kW	Power input kW	Cooling capacity kW	Power input kW
HFRWE-345TGF/AE	5°C	270.7	124.2	281.1	116.9	302.5	108.4	320.8	100.4	340.8	93.5	353.0	86.6	365.5	83.8	375.9	81.1
	7°C	286.4	126.2	297.2	120.1	321.8	110.9	345.0	104.0	360.4	96.4	370.1	89.7	382.2	87.0	395.9	83.2
	9°C	301.4	129.9	315.9	123.3	337.3	116.3	359.8	107.6	375.7	99.2	388.0	93.3	402.1	89.5	414.6	86.3
	12°C	323.0	135.5	336.2	129.5	357.8	121.9	378.6	113.6	392.2	104.2	407.1	97.8	423.3	94.4	439.5	90.5
	15°C	358.9	140.1	367.0	134.6	384.5	126.5	405.6	119.5	420.9	109.8	436.3	102.9	450.9	99.0	464.0	94.8

### Heating capacity

Model	Water outlet temperature (°C)	Ambient temperature (°C)															
		-15°C		-10°C		-5°C		0°C		7°C		10°C		15°C		21°C	
		Heating capacity kW	Power input kW	Heating capacity kW	Power input kW	Heating capacity kW	Power input kW	Heating capacity kW	Power input kW	Heating capacity kW	Power input kW	Heating capacity kW	Power input kW	Heating capacity kW	Power input kW	Heating capacity kW	Power input kW
HFRWE-345TGF/AE	35°C	218.1	81.2	240.2	83.1	271.9	85.3	321.5	86.4	369.6	87.5	393.0	88.6	416.0	89.5	426.7	90.2
	40°C	210.3	89.0	234.1	91.7	263.1	93.6	310.5	94.8	361.5	96.4	382.4	97.8	405.6	98.7	415.0	99.7
	45°C			229.8	99.2	257.9	101.4	301.6	103.5	355.0	105.0	376.4	106.8	396.0	108.1	405.6	109.7
	50°C					252.7	111.0	292.2	112.8	346.2	114.4	367.2	116.1	384.2	117.5	392.9	119.0
	55°C											357.3	125.8	372.5	126.9	382.0	128.2

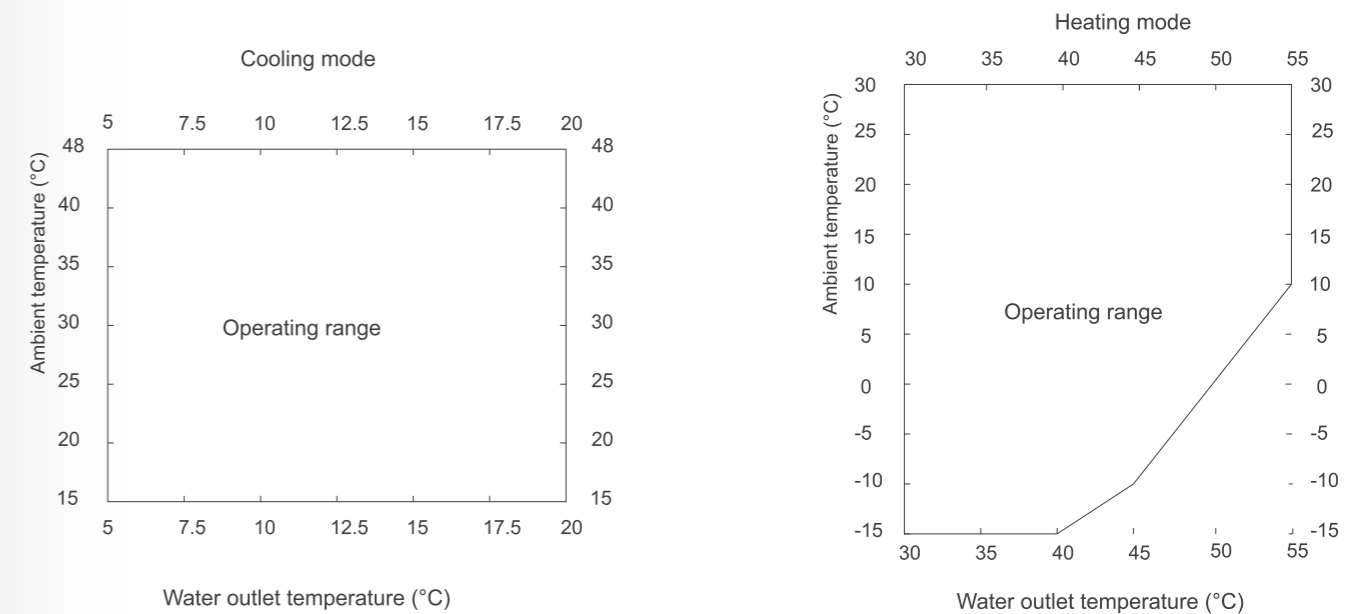



Unit dimensions

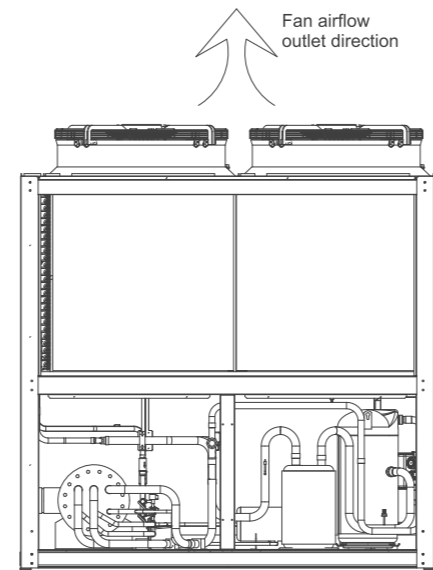
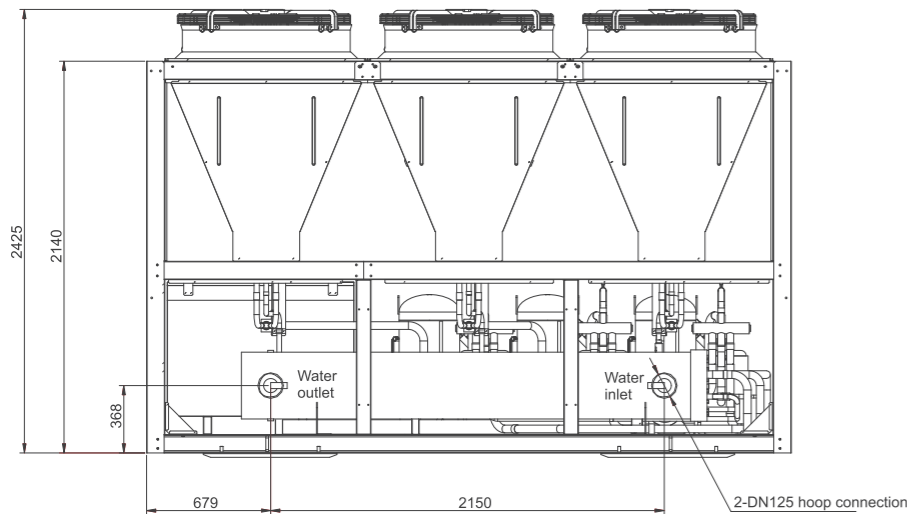
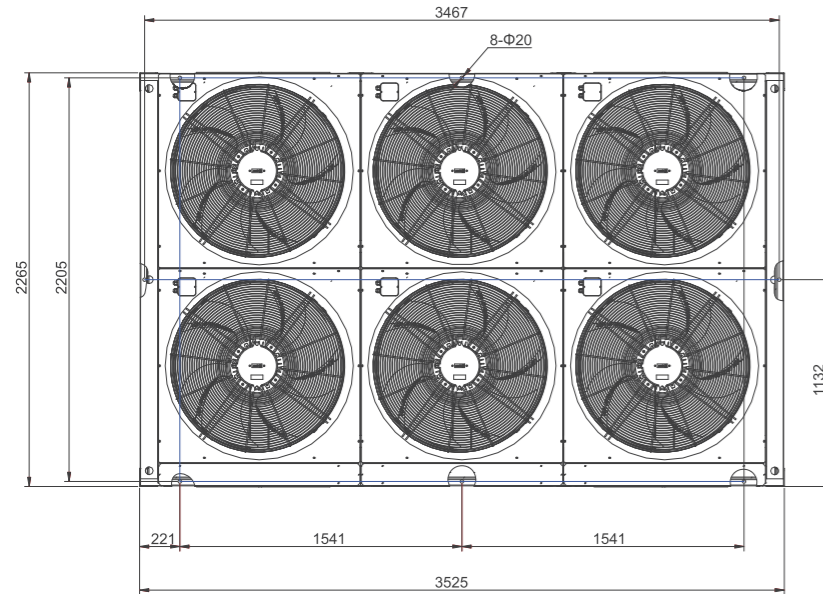

Installation foundation drawing

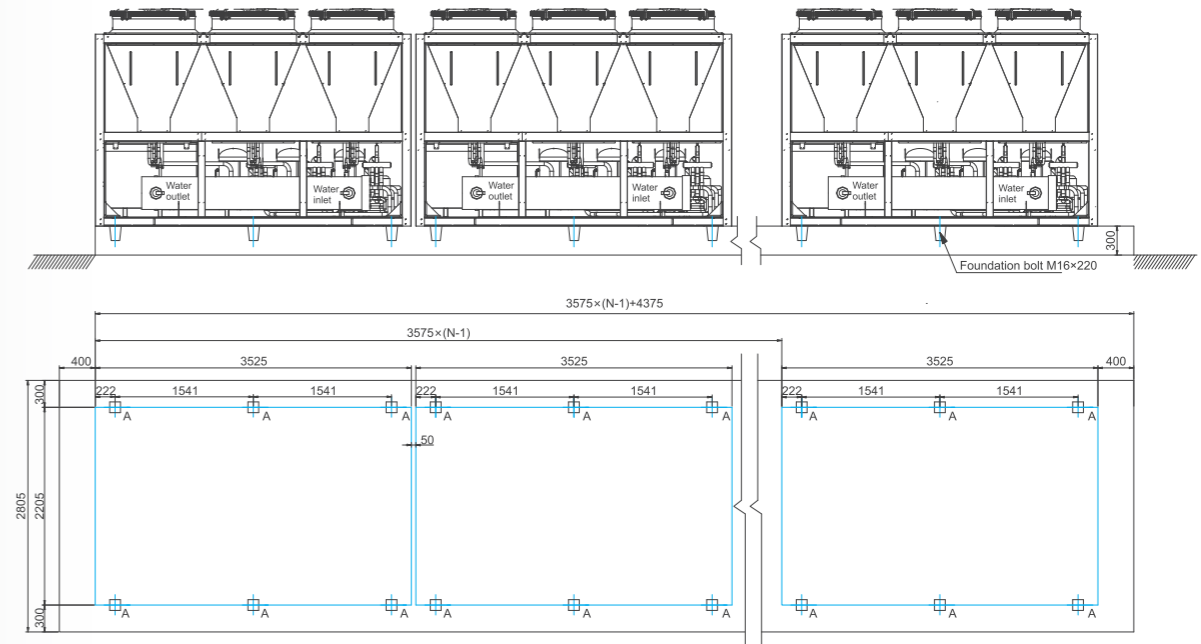

Note:

1. The installation foundation must be a concrete floor, channel steel frame structure or spring isolator that can withstand the operating pressure of the unit;
2. N indicates the total number of installed modules;
3. Each unit is fixed with six M16 bolts;
4. Six 20-mm thick rubber isolators should be installed between the unit and the installation foundation;
5. The installation foundation must be equipped with drainage facilities to facilitate the drainage of condensate and defrosting water.

Precautions for water system installation

- Adopt softened water for circulating water;
- Water supply safety valves are mandatory;
- The water flow cannot be lower than the nominal value of the unit;
- Set a suitable drain valve at the lowest point of the water system;
- It is recommended to install an adiabatic water storage tank of appropriate capacity, so as to avoid frequent startup of the unit due to too small load;
- An expansion tank must be equipped to adapt to changes in water volume caused by changes in water temperature in the water system;
- The waterway of the unit must be equipped with a bypass valve, and it must be ensured that the water system has been cleaned before the system can be filled with water and put into operation;
- An additional water filter is included randomly. Clean the water filter regularly according to the usage;
- It is recommended to check the water system every half a month;
- When connecting pipes in a reversed return system, the water pressure gauge of each module's inlet and outlet pipes can be omitted;
- Since the wired controller can check the inlet and outlet water temperature of each module, the thermometer can also be omitted.

**Note: The unit should be installed in a proper location because this also has a significant impact on the noise of the unit. In case of no proper noise reduction measures, the installation location of the unit in the following situations should be avoided:**

- 1) The unit is installed in a long and narrow building passage and faces the building wall with doors and windows on the side;
- 2) The unit is installed too close to noise-sensitive occasions, such as residential buildings, offices, conference rooms, and star hotel rooms;
- 3) The obstacle is very close to the air outlet of the fan, affecting the air flow of the fan system;
- 4) When the unit is equipped with an isolator, the external power cord box, external water pipes, etc. are hard connected to the ground (or the unit foundation), greatly reducing the effect of the isolator;
- 5) The unit is directly installed on the floor or the ground without concrete foundation and isolator;
- 6) The unit is installed on the top of the building, but is too close to the edge of the building. This may cause the noise to travel around the edge of the building to the downstairs, thus resulting in noise complaints;
- 7) The unit is installed in a public area with large flow of people, without taking any noise reduction measures.

# AIR-COOLED SCREW CHILLER

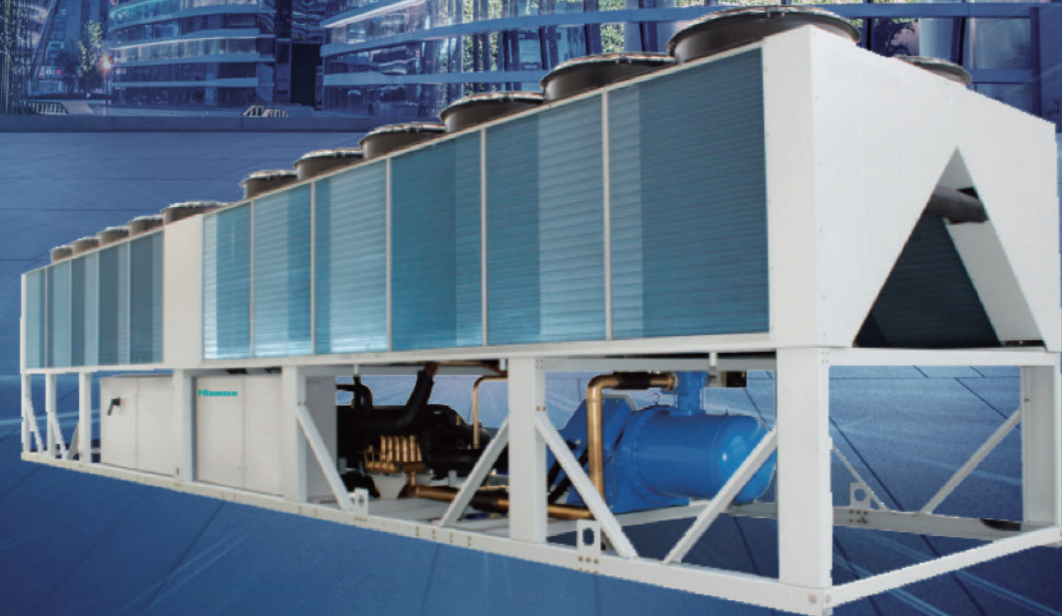

## Features

### Double Screw Compressor, High Efficiency and Low Noise

The air-cooled screw chiller adopts the new generation high-efficiency double screw compressor with HFC-134a, which is with 5:6 asymmetric rotor design, new screw profile and oil injection design.

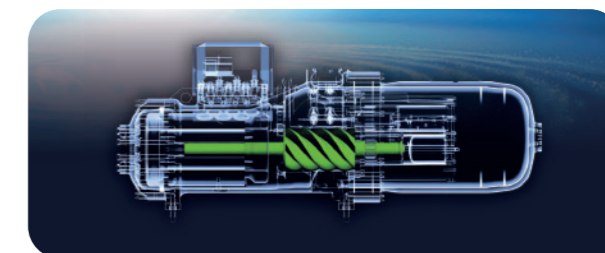

### Optimal Rotor Design

- The new generation HFC-134a high-efficiency double screw compressor uses the newly optimized 5:6 asymmetric rotor profile made using the patented production process, ensuring the rotor processing precision and optimal fit clearance of rotor.
- The one-shot moulded screw rotor effectively avoids the stress damage of late cutting processing and ensures the higher screw hardness and edge line velocity, shorter compression stroke and more efficient compression.

### Double-layer Pressure Compensation Shell

- The double-layer pressure compensation shell made through precision casting of nodular cast iron undergoes precision machining with the M/C machine tool, and a three-dimensional precision measurement instrument is used to check the machining precision so as to ensure that the compressor gap and precision can meet the requirement for efficient operation, and the double wall shell is rather stable and cannot be deformed even in a high pressure state. It not only complies with the pressurization requirement, but also reduces noises.
- The compressor housing adopts two stage casting and is divided into the compression side and oil separation side, with better pressurization performance. Meanwhile, the built-in pressure reducing safety valve can connect the high and low compression chambers for pressure relief, and the relative external safety valve avoids direct refrigerant leakage in the air.

### Bearing

- The patented closed pressure-reducing bearing chamber works with the long life bearing, and the pressure relief design of pressure bearing with double bearings is adopted in the axial direction to make the bearing solid and durable. The bearing chamber is separated from the high pressure chamber to reduce the bearing chamber pressure effectively
- and ensure viscosity of the lubricating oil in the bearing cavity. The excellent lubricating oil path fully lubricates the bearing, further increases the bearing service life and ensures safe operation of the unit.

### Air Inlet Filter

- The double-layer large-area air inlet screen is designed to ensure high strength and small pressure loss, not only protecting the compressor completely, but also ensuring long-term operation efficiency of the compressor.

### Oil Separator

- The innovative built-in three-stage oil separator adopts the internal three-section oil filter and works together with the high density screen to achieve the optimum oil and gas separation rate of over 99.8%.

### Oil Heater

- The compressor is designed with an oil heater to ensure that the lubricating oil still keeps enough viscosity after the unit has stopped for a long term, ensuring reliable operation of the compressor.

36

Features

44

Control System

46

Specification



Stepless Regulation

- The unit uses the slide valve-type load increase/decrease device and is configured with the highly reliable solenoid valve of international brand to implement precise control and stepless regulation in the range of 25% to 100%, thus realizing perfect matching with the actual load, ensuring highly efficient operation of the unit and saving energy as offering a comfortable environment.
- A sliding ECO air inlet is designed in the capacity adjusting slide valve mechanism, and ECO air supply is adjusted and changed along with load, making sure that the compressor energy efficiency can be fully exerted under the partial load.

Discharge Damping Silencer

- The discharge damping silencer designed based on the resonance principle can effectively reduce the vibration transmission, high frequency noise and the discharge noise of compressor.

Motor

- The unit uses the world-renowned high efficiency bipolar three-phase F-grade insulated inductive motor and built-in PTC thermistor and is configured with the intelligent imported motor protection module to protect the motor, accurately monitor the coil temperature of compressor motor and ensure normal operation of the compressor.
- The unique internal cooling channel is designed to ensure that the motor can operate for a long term in a wider compressor operating range. Both the step-down start and direct start modes can be realized.

Long Acting Oil Filter

- The compressor oil way is designed with a built-in 10-micron grade oil filter set with a metal filter screen of high precision to implement 10-micron long acting filtration. It fully filters impurities from the oil way to ensure safe operation of the compressor and needs no replacement throughout the service life of the compressor.

Efficient Heat Exchanger with Excellent Performance

- The heat exchanger adopts the optimized refrigerant distribution design and passes the three major certifications of ASME, PED and GB. The internal heat exchange tube adopts the efficient internal thread heat exchange copper tube to strengthen heat transfer at the water side and refrigerant side, optimize the heat transfer efficiency, reduce the unit's energy consumption, and cut the operating cost for the customer.
- The standard pipe connection mode provided by the heat exchanger is groove clamping connection (with short pipes) which facilitates field installation, and each evaporator is configured with the discharge and drainage devices separately.
- It facilitates the compressor return oil design, simplifies air return without requiring any oil pump and eradicates the frost crack danger of heat exchange tube; the refrigerant charge is only 1/3 of that of a common heat exchanger, without leakage, more reliable and environmentally friendly.
- The anti-freeze electric heater and anti-freeze temperature sensor are installed to implement anti-freeze protection for the unit, and the large barrel type water filter and water flow switch are configured for the water system as additional accessories to implement multi-protection for the waterway system.



Inverted M Type Heat Exchanger of Air Side, Improving the Heat Transfer Effect

- The inverted M type heat exchanger adopts the cooling and heating separation design to effectively reduce the pressure loss of refrigeration system and improve the unit operation efficiency.
- The airflow distribution is even and consistent thanks to the CAE analysis, with no blind zone of heat exchange, realizing high-efficiency heat exchange.

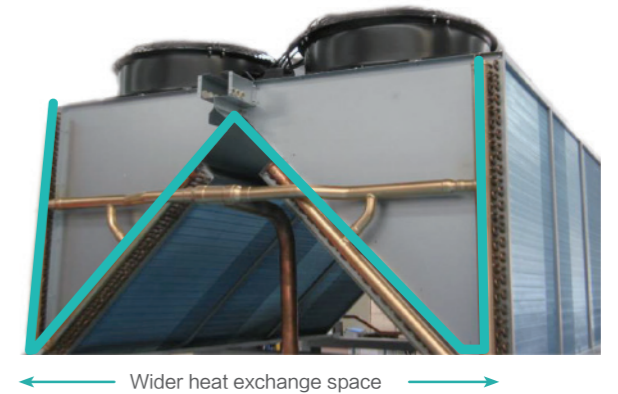

- The unit adopts the seamless inner grooved copper tube of famous brand and the world leading continuous casting and rolling technology to achieve the excellent extension and heat exchange performance. Moreover, heat shrink sleeving is allocated to every heat exchanger distributor to realize shock proof and abrasion proof design.
- Copper tubes for the heat exchanger undergo full mechanical expansion and are staggered and covered with corrugated aluminum condensing fins. In comparison with the fenestrated aluminum fin, the fin features small wind resistance, low dust accumulation probability and reduced heat exchange efficiency attenuation during long term operation, ensuring stable and long term heat exchange of the unit.

Item	Hisense corrugated aluminum fin	Fenestrated aluminum fin (other brands)	Disadvantages of fenestrated aluminum fin
Dust accumulation probability	Small	High	High rate of dust accumulations, fast attenuation of heat exchange efficiency, and low efficiency
Cleaning probability	Small	High	High rate of cleanings and considerable maintenance cost
Wind resistance	Small	High	Big wind resistance, improved fan energy efficiency, and increased operating cost
Defrosting	Easy	Difficult	Hard defrosting, easy secondary frosting, and reduced water temperature of heating, not applicable to the heat pump condition



### Two-stage Supercooling Technology

#### First-stage Supercooling:

The special secondary distribution technology of refrigerant is adopted to recollect the liquid refrigerant, which passes the recooling coil bottom and undergoes one time supercooling to improve the cooling energy efficiency and capacity effectively.

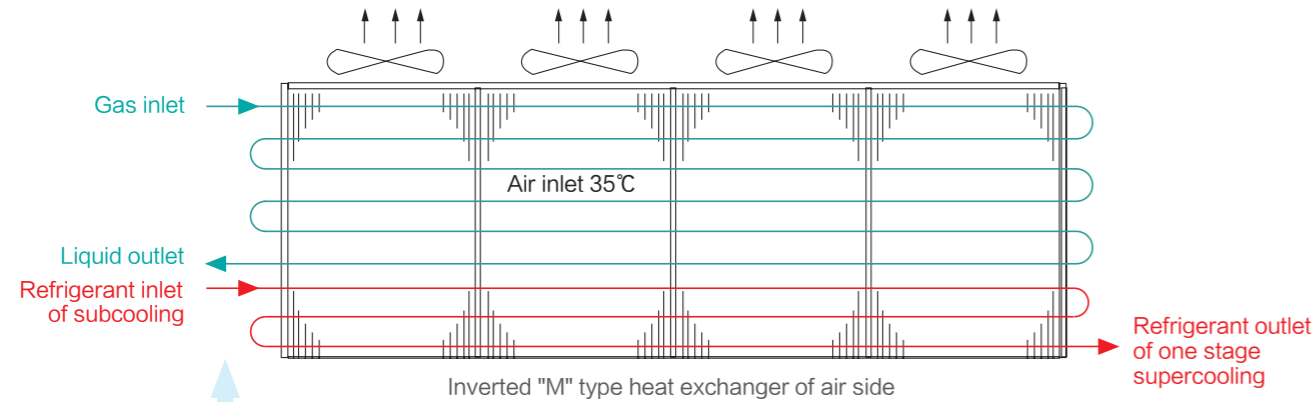

First-stage supercooling realized easily through the unique refrigerant distribution technology of Hisense.

First-stage supercooling of condenser

#### Second-stage Supercooling:

The efficient economizer implements two stage supercooling and adopts the independent electronic expansion valve to realize accurate throttling control. The differential pressure between the inlet liquid refrigerant and outlet liquid refrigerant is detected to achieve the best control on supercooling degree, further enhance the unit supercooling degree and improve the energy efficiency of main unit.

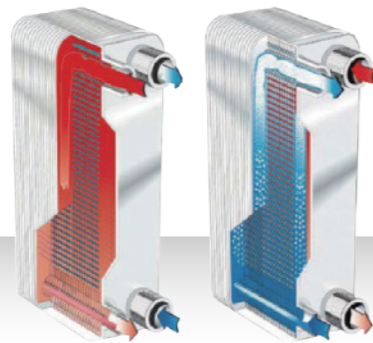

Second-stage supercooling of the economizer

### High Precision Control, Reliable Operation

- The high performance double-screw compressor specially developed for the HCF-134a heat pump, high grade bearing, lubricating oil path design without oil pump, and suction spray and intermediate spray protection of the compressor guarantee extremely safe operation of the compressor.
- The three-level password protection prevents wrong operation of non-professionals and ensures safe operation of the unit. The multi-protection function ensures safe operation of the unit.
- The unit (with standard configuration) adopts outlet water temperature control to ensure constancy of the outlet water temperature, make the terminal temperature regulation more accurate and optimize the user experience; return water temperature control can also be selected to achieve the best unit efficiency under dynamic equilibrium of end user.
- The compressors start one by one to minimize the startup current and reduce the impact on the power grid.



### Anti-frosting Design of the System (Optional)

#### Unique Defrosting Heat Exchanger (Special)

- The difficulty of icing at the bottom of the finned heat exchanger in winter is eliminated to improve the heating efficiency and save more energy.
- The traditional heat exchanger is narrow at the bottom, and the melt water during defrosting easily gathers to lead to ice accretion.
- The unique flow path design of Hisense can gather waste heat during defrosting to make it pass through the bottom of the flow path, avoiding ice accretion at the bottom during defrosting at low temperature and realizing more thorough defrosting.



Special heat exchanger design for supercooling defrosting



### Wider Operation Range and Longer Service Life

- The unit casing adopts the galvanized steel sheet (complying with the EU ROHS standard), undergoes electrostatic orange pattern spraying with anticorrosive paint, and uses stainless steel screws to prevent corrosion effectively and adapts to various outdoor adverse conditions.
- The unit can cope with the outdoor wide temperature range of  $-10^{\circ}\text{C}$  to  $50^{\circ}\text{C}$ .
- The unit supports air-to-air heat exchange that does not pollute the environment and meets environmental regulations.

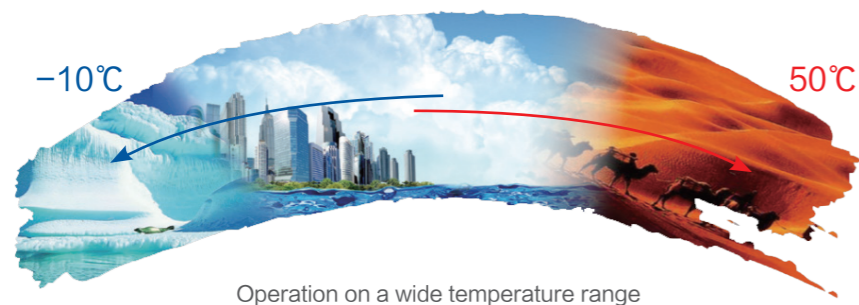

### Accurate and Stable EEV Control

The 0~3810 step electronic expansion valve control technology can realize fine adjustment in the range of 10% to 100%, achieve best control on the superheat degree and ensure high performance operation of the unit.

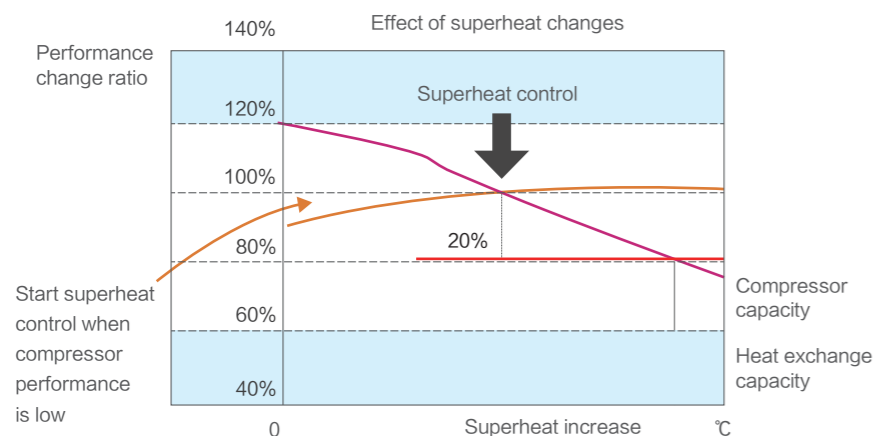

Note:  
Decreased or unstable superheat will reduce the performance of the compressor, and even prevent the refrigerant from evaporating, resulting in liquid compression, resulting in compressor failure. Increased superheating will reduce the performance of the water-side heat exchanger.



Note:  
The unit uniquely adopts the dual power supply design of electronic expansion valve to implement power-off delay protection and prevent hidden danger of liquid hammer against the compressor when the power supply of the unit fails unexpectedly.

### Environmentally Friendly Refrigerant R134a

The environmentally friendly refrigerant R134a with excellent performance saves power consumption and contains no chlorine element, so it does not damage the atmospheric ozone layer and has no forbidden period. The refrigerant reduces  $\text{CO}_2$  emission effectively, alleviates the increasingly serious urban heat island effect and constructs green life buildings.



### Optimal Aerofoil Spiral Fan, Large Airflow with Low Noise

- The fan adopts aerofoil axial fan design, which looks like the bird's wings. It can effectively decrease the noise from the air interference. Moreover, it adopts large diameter aluminum blade to achieve higher airflow.
- Through the optimized design of the front end of the curved impeller, the generation of air vortex at the edge of the fan impeller is controlled, improving the fan efficiency and lowering the fan noise.
- The motor ensures zero idling and provides the thermal protection function, with a longer service life.
- The motor is directly driven to eliminate transmission loss effectively and reduce vibration.
- In addition, a high static pressure fan motor is optional, meeting all kinds of scenarios with static pressure requirements.

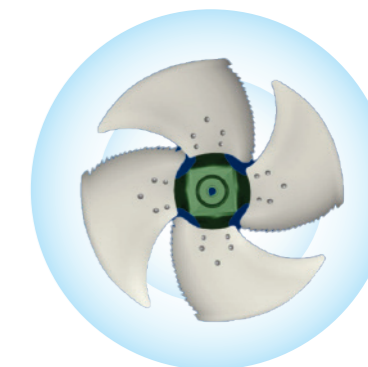

### Convenient Installation and Simple Maintenance

- The unit adopts the integral structure. One unit adopts the one inlet and one outlet system for the waterway to achieve simple installation. The user only needs to connect the power supply and water supply before operation, and does not need to rebuild an equipment room or purchase cooling tower and other auxiliary equipment, so the construction period can be shortened effectively and the installation cost is cut down.
- Due to the integrated design of the electrical part and the main unit, the user does not need to set a special power distribution cabinet, saving the complex power distribution work.
- Electrical layout adopts strong and weak current separation, switch design of power-on interlock and unique integrated design of electric shock prevention. The strong current cabinet is equipped with an anti-shock insulating glass baffle, and the standard main line configured for the electric control cabinet of unit is connected to the protection box to prevent electric shock.
- The intelligent control system automatically monitors and controls the operating status of the unit and displays the fault cause in case of an exception to facilitate unit maintenance.



Strong current part

Interlocking main switch

Weak current part



### Optimization Measures of Noise Reduction

- Source noise reduction: The double-wall pressure compensation shell reduces noise transmission from the source, the high precision rotor undergoes cutting-edge machining to ensure the meshing accuracy, and the rotor compression surface undergoes laser hardening treatment and cannot be deformed under compression force. The minimal vibration and smooth operation reduces the operating noise effectively.
- Exhaust noise reduction: The compressor is provided with a built-in discharge damping silencer, which is designed according to the resonance principle to effectively reduce the noise generated by high pressure discharge vibration of the compressor.
- Fan noise reduction: The unit employs the most advanced aerofoil type spiral fan with a large diameter aluminum blade, which looks like a bird's wings unfolded, and the sickle-shaped fan controls generation of air vortex at the fan impeller edge. The noise is reduced by 6 dB(A) in comparison to the common axial fan.
- Noise reduction measures for unit vibration: Flexible fastening parts are used at the key nodes of pipeline to reduce vibration effectively, and the directions of all the copper tubes are systematically optimized to greatly reduce the operating vibration of the unit body.
- Noise reduction during operation: The standard combined spring shock absorber is configured for the unit before delivery, the quantity, bearing points and bearing specifications of the configured shock absorbers are matched according to the weight and structural center of gravity of the corresponding unit, and the user can install a spring shock absorber between the unit bottom frame and the foundation to greatly reduce vibration transmission during operation of the unit, better reducing noise during operation.

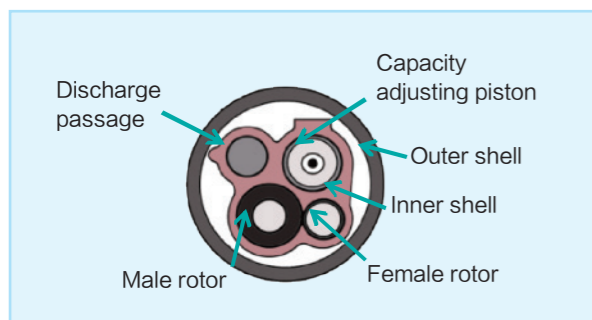

Section sketch map of double layer casing

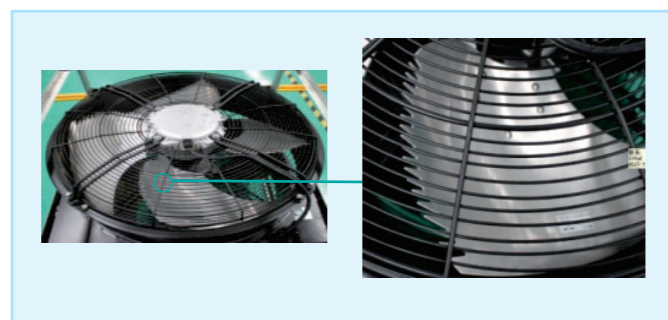

Advanced aerofoil type spiral design

### Ultra Low Noise Type (Optional)

- Sound insulation and noise reduction: The unit adopts the sound proof box (optional) of compressor, which is pasted with 40 mm efficient sound absorbing material. This method can be used to reduce noise by 6 dB(A).
- Flexible soft connection (optional): The flexible connection of the suction side and discharge side of the compressor can be used to further reduce the suction/discharge noise of the compressor.
- Fan speed control (optional): The fan motor adjusts the motor speed according to the system temperature detected by the sensor and reduces the operating noise of the unit during partial load.



## Control System

### Hisense Intelligent Group Control System

- Hisense provides the intelligent group control system software, which can implement centralized control on multiple main units, automatically balance the operating time of multiple units, and perform automatic switching when a unit fails, making the system operate more intelligently and stably and achieving the objective of energy conservation.
- The system adopts the international RS485 standard serial communication interface, and can be connected with other building control systems (BAS) through the communication protocol conversion module (optional) provided by Hisense to realize group control of multiple units. The standard protocol includes BacNet, Modbus and Lonworks.
- The 10-inch large LCD touch screen display digital control center professionally developed by Hisense provides monitoring, data recording, safety protection and convenient operation for the system. A series of technical information can be displayed just by pressing a single key. Obviously, it makes the operation of the unit more convenient.
- The LCD displays the information about the water chiller, subsystem and system parameters, and can display multiple operating parameters simultaneously on the same screen. Besides, the administrator can also set an access password to prevent change to the set value without permission.



### "Black Box" Function

The unit is equipped with an advanced microcomputer controller with "black box" function, which can monitor and store the operating parameters of the unit in real time, and can continuously record all the data of the unit's operating status in the past year. Also, it can quickly and accurately check the abnormal operation, easy to analyze and solve the problems.

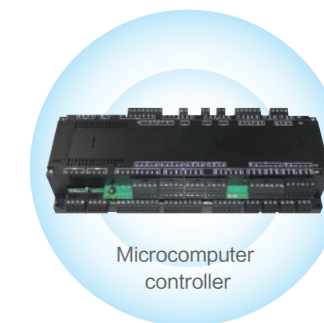



### Displaying Information

The control center implements continuous monitoring of the operating system and displays the unit running status and fault information.

The displayed status information includes, but not limited to:

- Unit status
- Unit capacity
- Compressor, water pump and expansion valve status
- Inlet and outlet water temperatures
- Suction/discharge pressure/oil pressure of compressor
- Suction/discharge temperature/oil temperature of compressor, etc.

Alarm information includes, but not limited to:

- Power supply over/under-voltage and reverse phase/phase loss protection
- Compressor high/low voltage protection
- Compressor and fan overload protection
- Oil filter clogging protection
- Discharge temperature high protection
- Anti-freezing protection, cutoff protection and frequent start/stop protection
- Feedback on various pressure/temperature sensor faults, etc.

### Functions

- Three level password protection of factory, service and user
- Power-on self-test function
- Weekly timed-on/off function
- Memory function in power failure
- Unit preheating
- Outlet/return water temperature setting/control
- Automatic/manual control of unit operation
- Balancing compressor operating time
- Delayed start control of compressor
- Compressor start time setting
- Compressor energy regulation control/setting

### Unit Configuration

#### Standard unit accessories

- Spring shock absorber
- Water filter
- Water flow switch
- Clamp

### Unit Options

- Low temperature cooling type/annual heat pump type
- Plateau type
- Ultra low noise type
- "Hisense Cloud" remote monitoring
- Centralized controller
- Remote touch screen controller
- Soft starter/inverter start
- Building automation interfaces – Modbus, LonWorks, BACnet
- Flange interface
- Anticorrosive fin
- Water side pressure bearing 1.6 Mpa
- Built-in hydraulic module (some models are available)

Note: For the above options, contact the local office.

## Specification

Model	HFRLGE -GH/AE	093S	109S	126S	132S	146S	168S	180S	188S	202D	218D	
Nominal cooling capacity	kW	308.5	367.2	414.5	442.6	483.5	549.3	594.3	632.8	683.8	734.4	
	USRT	87.7	104.4	117.8	125.9	137.5	156.2	169.0	179.9	194.4	208.8	
	× 10 <sup>4</sup> kcal/h	26.5	31.6	35.6	38.1	41.6	47.2	51.1	54.4	58.8	63.2	
Nominal heating capacity	kW	292.1	346.8	393.7	419.5	457.3	520.3	562.2	602.2	648.0	693.6	
	USRT	83.0	98.6	111.9	119.3	130.0	147.9	159.8	171.2	184.2	197.2	
	× 10 <sup>4</sup> kcal/h	25.1	29.8	33.9	36.1	39.3	44.7	48.3	51.8	55.7	59.6	
Cooling power input	kW	104.9	123.7	138.2	148.6	162.5	183.7	200.4	209.5	230.6	248.6	
Heating power input	kW	98.0	115.8	129.1	135.4	149.0	166.9	190.7	197.7	214.0	232.4	
Control type	-	25%~100% stepless regulation									12.5%~100% stepless regulation	
Startup type	-	Y-Δ										
Power supply	-	AC 3Φ, 380V/50Hz										
Refrigerant	Type	R134a										
	Circuits No.	No.	1	1	1	1	1	1	1	1	2	2
	Control type	-	Electronic expansion valve									
Compressor	Type	Semi-hermetic dual-screw type										
	Qty	No.	1	1	1	1	1	1	1	1	2	2
Fan	Type	Spiral axial fan										
	Qty	No.	6	8	8	10	10	12	12	14	14	16
	Power input	kW	9.6	12.8	12.8	16	16	19.2	19.2	22.4	22.4	25.6
	Air flow	× 10 <sup>4</sup> m <sup>3</sup> /h	12	16	16	20	20	24	24	28	28	32
Air-side heat exchanger	Type	Fin tube type										
	FPI	Inch	16FPI									
Water-side heat exchanger	Type	Dry shell and tube type										
	Water flow under cooling	m <sup>3</sup> /h	53.1	63.2	71.3	76.1	83.2	94.5	102.2	108.8	117.6	126.3
	Water flow under heating	m <sup>3</sup> /h	50.2	59.6	67.7	72.1	78.7	89.5	96.7	103.6	111.4	119.3
	Water resistance	kPa	38	44	48	36	34	47	54	56	48	61
	Diameter of connected pipe	Inch	8	5	5	6	6	6	6	6	6	
Rated current	A	209	240	258	279	303	339	353	371	449	480	
Max. operating current	A	275	303	338	345	385	434	505	512	578	606	
Max. startup current	A	414	649	710	710	882	882	1007	1007	689	952	
Unit dimensions	Length	mm	3750	4650	4650	5550	5550	6450	6450	7350	8000	8900
	Width	mm	2260	2260	2260	2260	2260	2260	2260	2260	2260	2260
	Height	mm	2525	2525	2525	2525	2525	2525	2525	2525	2525	2525
Unit weight	Transportation	kg	3528	4453	4463	5621	5881	5861	5961	6887	7588	8414
	Operation	kg	3728	4653	4713	5924	6184	6211	6311	7307	8008	8834

Notes:

- Cooling design condition: outdoor dry bulb temperature 35°C, outlet water temperature 7°C and water flow 0.172 m<sup>3</sup>/(h · kW).
- Power distribution and wiring on the unit installation site are subject to the unit nameplates or installation instructions.



Model	HFLGE -°GH/AE	247D	257D	277D	291D	313D	335D	359D	371D	388T	420F	
Nominal cooling capacity	kW	823.9	882.0	929.1	961.0	1031.9	1099.2	1181.7	1265.7	1316.7	1418.2	
	USRT	234.3	250.8	264.2	273.2	293.4	312.5	336.0	359.9	374.4	403.2	
	× 10 <sup>3</sup> kcal/h	70.9	75.9	79.9	82.6	88.7	94.5	101.6	108.8	113.2	122.0	
Nominal heating capacity	kW	781.2	837.5	878.1	908.7	975.9	1043.0	1107.6	1210.0	1250.2	1341.6	
	USRT	222.1	238.1	249.7	258.4	277.5	296.6	314.9	344.0	355.5	381.4	
	× 10 <sup>3</sup> kcal/h	67.2	72.0	75.5	78.1	83.9	89.7	95.2	104.1	107.5	115.4	
Cooling power input	kW	277.2	296.5	311.4	325.1	346.9	368.4	401.7	421.5	440.0	479.1	
Heating power input	kW	256.7	269.0	281.9	294.0	313.5	333.5	381.3	395.2	411.7	446.4	
Control type	-	12.5%~100% stepless regulation								8.3%~100% stepless regulation	6.3%~100% stepless regulation	
Startup type	-	Y-Δ										
Power supply	-	AC 3φ, 380V/50Hz										
Refrigerant	Type	R134a										
	Circuits No.	No.	2	2	2	2	2	2	2	2	3	4
	Control type	-	Electronic expansion valve									
Compressor	Type	Semi-hermetic dual-screw type										
	Qty	No.	2	2	2	2	2	2	2	2	3	4
Fan	Type	Spiral axial fan										
	Qty	No.	16	20	20	20	22	24	24	28	28	30
	Power input	kW	25.6	32	32	32	35.2	38.4	38.4	44.8	44.8	48.0
Air-side heat exchanger	Type	Fin tube type										
	FPI	Inch	16FPI									
Water-side heat exchanger	Type	Dry shell and tube type										
	Water flow under cooling	m <sup>3</sup> /h	141.7	151.7	159.8	165.3	177.5	189.1	203.3	217.7	108.8+117.6	117.6+126.3
	Water flow under heating	m <sup>3</sup> /h	134.4	144.1	151.0	156.3	167.9	179.4	190.5	208.1	103.6+111.4	111.4+119.3
	Water resistance	kPa	56	61	56	70	55	80	90	71	56/48	48/61
	Diameter of connected pipe	Inch	6	6	8	8	8	8	8	6+6	6+6	
Rated current	A	514	556	582	606	642	677	706	743	820	929	
Max. operating current	A	676	690	730	770	819	868	1010	1024	512+578	578+606	
Max. startup current	A	1048	1055	1227	1267	1316	1316	1512	1519	1007+689	689+952	
Unit dimensions	Length	mm	8900	10700	10700	10700	11600	12500	12500	14300	15350	16900
	Width	mm	2260	2260	2260	2260	2260	2260	2260	2260	2260	2260
	Height	mm	2525	2525	2525	2525	2525	2525	2525	2525	2525	2525
Unit weight	Transportation	kg	8447	8643	9685	9785	9769	10813	11123	11523	13742	14938
	Operation	kg	8867	9063	10165	10265	10269	10703	11623	12123	14542	15758

Notes:

- Cooling design condition: outdoor dry bulb temperature 35°C, outlet water temperature 7°C and water flow 0.172 m<sup>3</sup>/(h · kW).
- The HFLGE-390T\* and HFLGE-420F\* units consist of the master unit and slave unit, which are transported to the site by segment for combination.
- Power distribution and wiring on the unit installation site are subject to the unit nameplates or installation instructions.

Working temperature range of units

	Cooling	Heating
Outdoor maximum temperature (°C)	50	50
Outdoor minimum temperature (°C)	5	-10
Water side maximum outlet water temperature(°C)	15	55
Water side maximum temperature difference (°C)	8	8
Water side minimum temperature difference (°C)	4	4

Notes:

If the cooling at the ambient temperature -15°C to 5°C is required, contact the technical personnel at your local office of Hisense.

Altitude correction factor

Altitude (m)	0	300	600	900	1200	1500	1800
Atmospheric pressure (bar)	1.013	0.977	0.942	0.908	0.875	0.843	0.812
Cooling correction factor	1.000	0.993	0.986	0.979	0.973	0.967	0.960
Input power correction factor	1.000	1.005	1.009	1.015	1.021	1.026	1.031

Correction factor for adding ethylene glycol

Ethylene glycol solution concentration (%)	10	20	30	40	50
Cooling capacity correction factor	0.991	0.982	0.972	0.961	0.946
Input power correction factor	0.996	0.992	0.986	0.976	0.966
Water flow correction factor	1.013	1.040	1.074	1.121	1.178
Water pressure drop correction factor	1.070	1.129	1.181	1.263	1.308

Correction factor of operating performance at low temperature

Ethylene glycol chilled water outlet temperature (°C)	2	0	-2	-4	-6	-8
Maximum outdoor ambient temperature (°C)	40	39	38	37	36	35
Cooling capacity correction factor Compressor input	0.842	0.785	0.725	0.67	0.613	0.562
power correction factor	0.95	0.94	0.92	0.89	0.87	0.84
Minimum ethylene glycol solution concentration (%)	10	20	20	30	30	30

# Hi-SC S SERIES

## HISENSE WATER-COOLED SCREW CHILLER

Hi-SC S Series is designed to provide efficient cooling for large buildings and facilities. It is featured with twin screw compression technology and triple lubricant protection measures for high-efficiency and reliable operation.

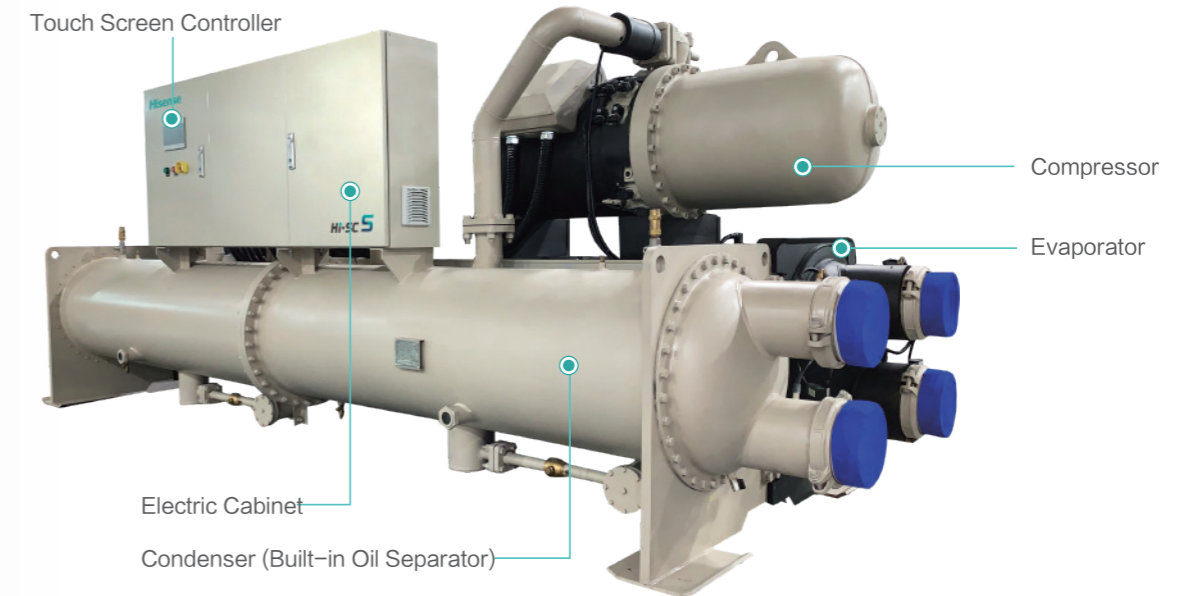

## NOMENCLATURE

HS LG E - 210 S M H / A H

- **Product series code:**  
H - high efficiency, E - standard
- **Product category code:**  
A - conventional series, R - heat recovery series
- **Refrigerant category code:**  
H - R134a, F - R410A, N - R407C
- **Evaporator type:**  
M - flooded type, J - falling film type, G - dry expansion type
- **Compressor quantity:**  
S - single-compressor, D - double-compressor, T - triple-compressor
- **Product specification code:**  
Unit - RT
- **Compressor type:**  
LG - screw type, W - scroll type, LX - centrifugal type
- **Product classification code:**  
HS - Hisense water-cooled unit



50  
Introduction

51  
Characteristics

61  
Technical Parameters

62  
Installation



# CHARACTERISTICS

## Advanced Components

### Well-proven Twin-screw Compression Technology, Efficient and Stable

The well-proven twin-screw compression technology allows fewer running components and higher reliability for the compressor.

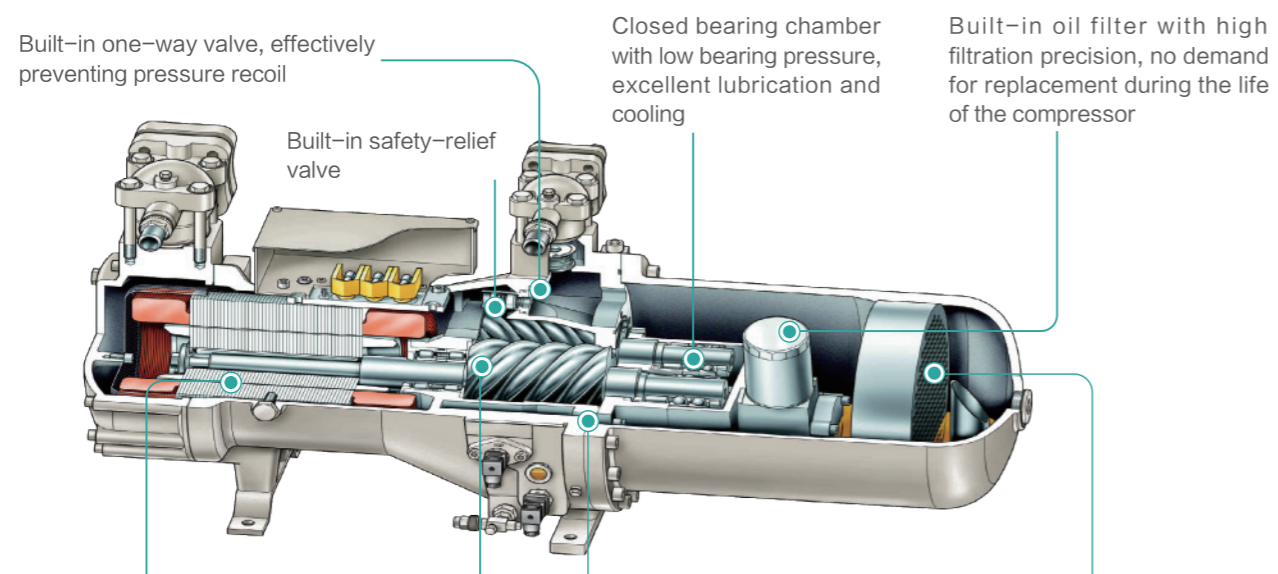

The high efficiency motor is designed with an optimized suction cooling channel for safe and efficient operation under all working conditions

R134a special rotor profile and direct-drive motor, more efficient

Double-layer cast body, less noise

Efficient three-stage oil separation system

### High-efficiency R134a Screw Rotor Profile, High Compression Efficiency

- New high-efficiency R134a special rotor profile ensures high-efficiency operation of compressor.
- Using the new material processing techniques, brings greater hardness and larger edge line speed, which ensures efficient and reliable operation of compressor.

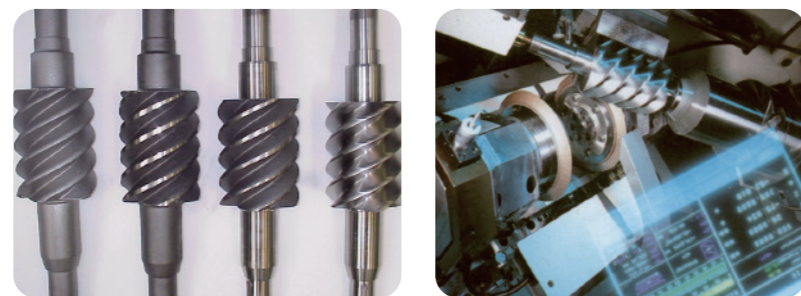

### Built-in Integrated Oil Separator for Compressor

- The compressor has three-stage oil separation, which brings up to 99.5% oil separation efficiency, ensuring safe and reliable operation and improving heat transfer efficiency.

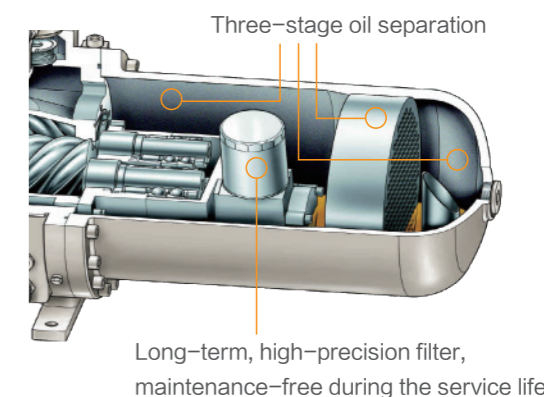

### Reliable Lubricating Oil Channel and Favorable Bearing and Rotor Lubrication

- The compressor employs differential pressure oil supply by the high and low pressure difference of the compressor itself, with no need for special oil pump.
- Low pressure bearing sealed chamber with better bearing lubrication.

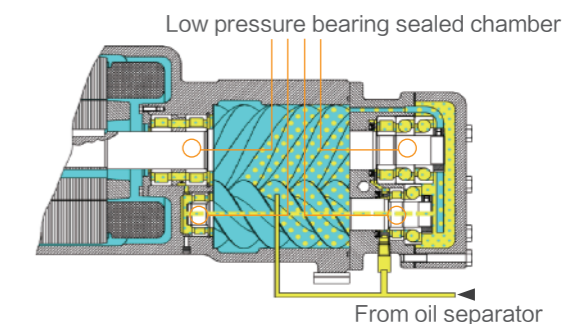

### Integral Cast Body, Reducing Leakage and Errors

- The motor side and the screw side of the unit are cast in one piece, reducing the risky of leakage from flange connections.
- Integral cast body avoids human error during the motor-screw connection.

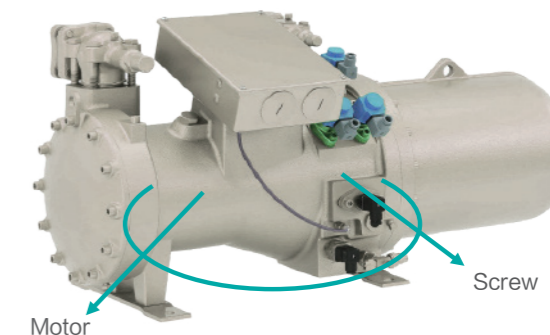

### Double-layer Cast Housing, Significantly Reducing Noise

- Double-layer body provides pressure compensation, greatly reducing the noise.
- The cast iron construction of the body and the oil separator can dramatically reduce the noise.

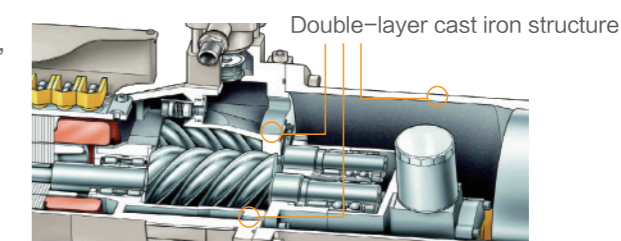



Stepless Compressor Load Adjustment and Stable Water Output

- ON-OFF switch of the solenoid valve controls the level of oil pressure in the piston cavity, so as to push the spring-pressed piston to drive the slide valve to move sideways for continuous stepless loading and unloading.

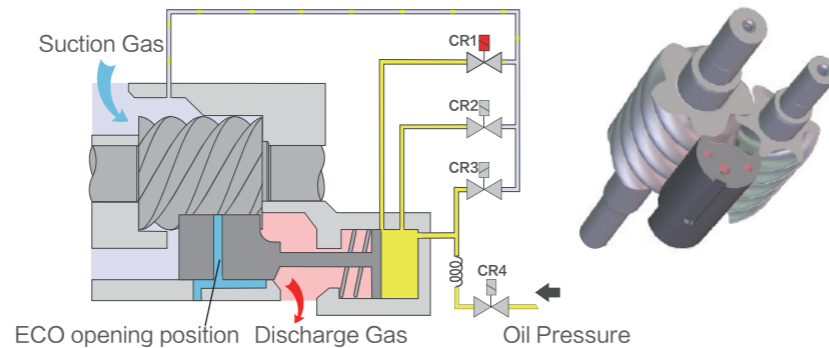

Reliable Bearing Operation Thanks to the Low Pressure Bearing Sealed Chamber

- Low pressure bearing sealed chamber is introduced to ensure low bearing pressure, excellent lubrication and cooling effect, gaining more reliable bearing operation.

Built-in High-precision Filter

- A high-precision filter is built in. There is no need to replace it during the service life of the compressor

Three-stage Oil Return Technology

The three-stage oil return technology ensures sufficient oil supply for the compressor, while avoids excessive oil entering the system to lower the heat transfer efficiency, so as to ensure stable and efficient operation of the system.

First-stage oil return

There is a built-in oil separator in the compressor. After compression, the mixture of oil and refrigerant can be separated when going through the built-in oil separator. Only a small amount of oil can be brought out of the compressor.

Second-stage oil return

The refrigerant discharged from the compressor will pass through the second-stage oil separator built inside the condenser for secondary operation. The majority of the lubricating oil will return the compressor through the oil return pipe at the bottom of the oil separator.

Third-stage oil return

A very small amount of lubricating oil enters the refrigerant system along with the refrigerant and then remains in the evaporator. At this point, the third-stage injection oil return will pump the lubricating oil back to the compressor completely.

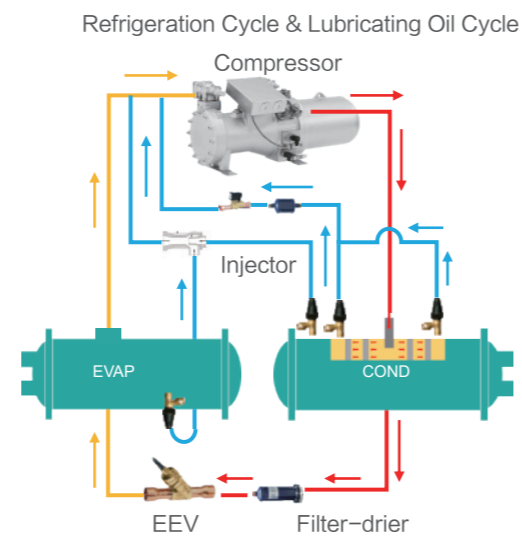

High-efficiency direct-drive motor with optimized refrigerant cooling channel

The high-efficiency motor is designed with an optimized suction cooling channel for safe and efficient operation under all working conditions.

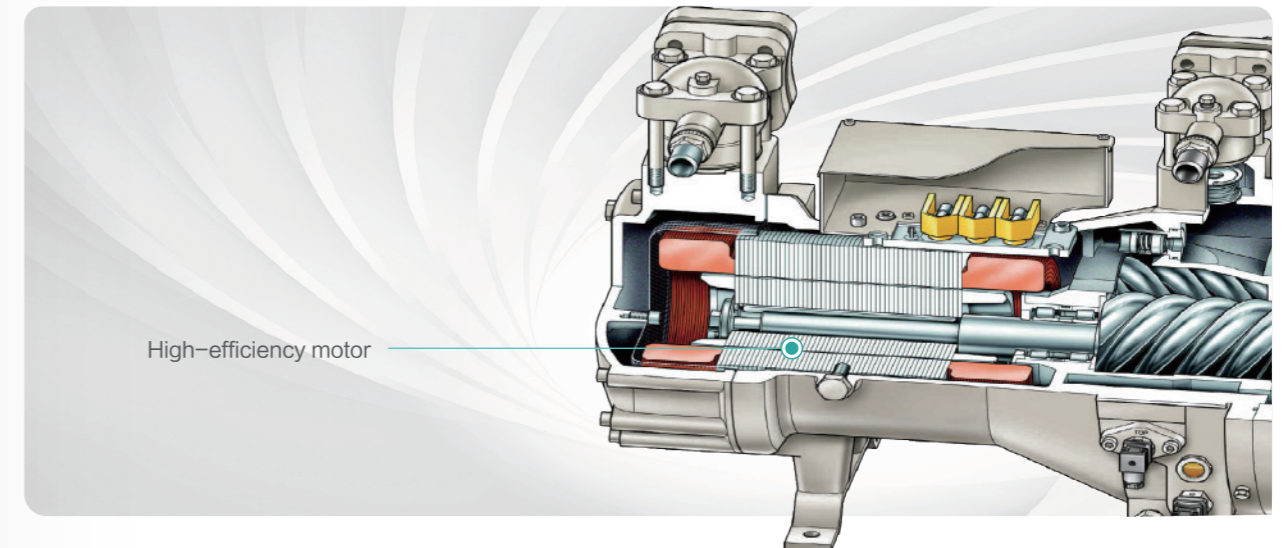

New High-efficiency Flooded Evaporator

- The unique liquid homogenizing plate design and optimized heat exchange tube arrangement ensure uniform refrigerant distribution and sufficient heat exchange.
- The high-efficiency internal and external ribbed copper tube tooth profile for flooded evaporator improves heat exchange efficiency.
- CFD simulation is applied to perform numerical simulation and analytical study of finite elements. Experimental results are reliably analyzed to further optimize the gas channel, ensuring efficient heat transfer.
- The copper tube is immersed in the refrigerant, and a strong nucleate boiling is formed on the surface of the copper tube, giving high heat transfer efficiency.
- The water flows inside the copper tube so that the heat exchanger is easy to clean.

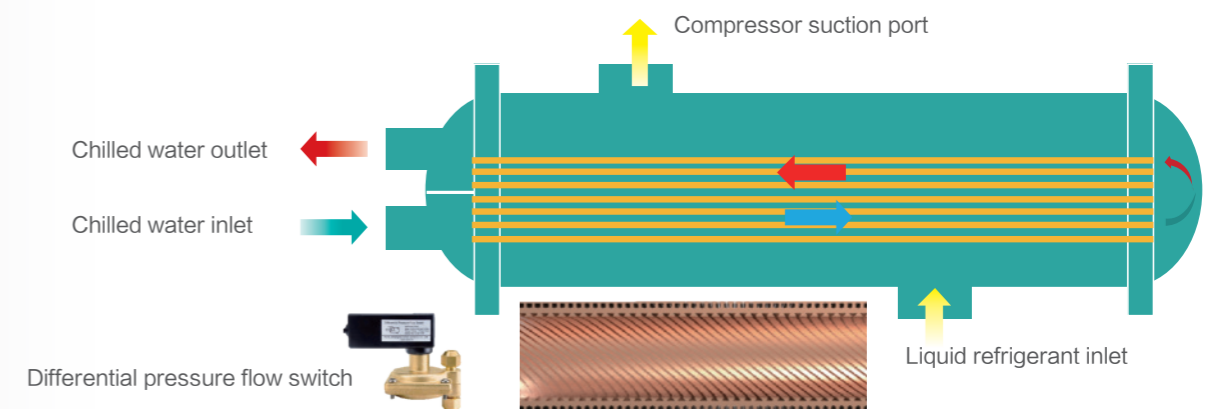



### Sensitive and High-precision Magnetostrictive Liquid Level Sensor

- Magnetostrictive liquid level detection technology is used to monitor liquid level in real time.
- High precision to micron level with small error.
- Sensitive and quick response.
- Easy to install and use, no need for regular calibration or maintenance.
- No need for zero setting after power-down.

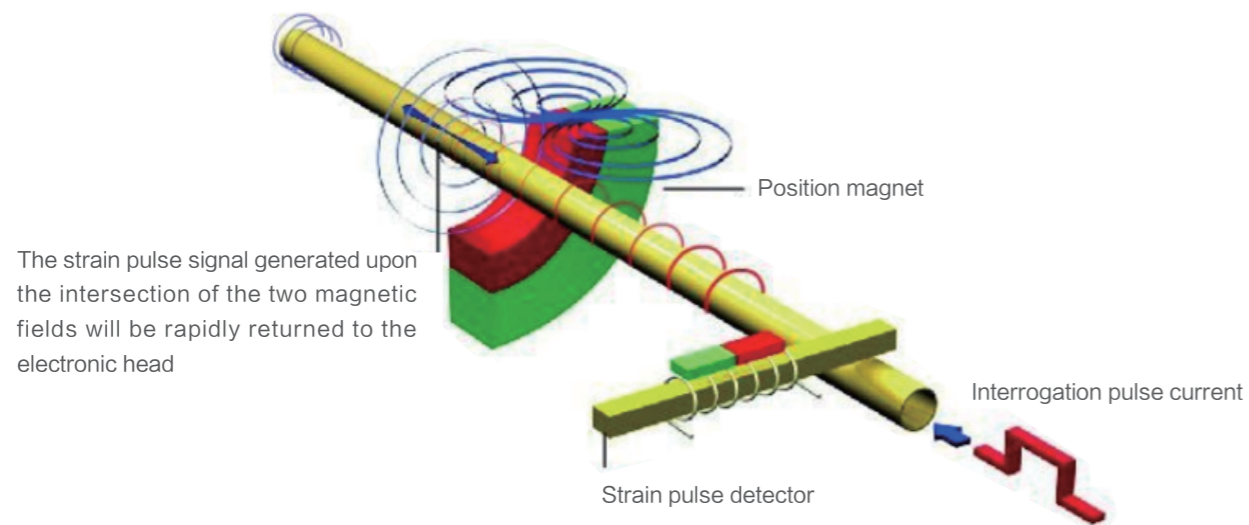

### High-precision Electronic Expansion Valve

- More precise control of evaporator liquid supply and smoother control of water temperature.
- Advanced balanced flow port design allows for bi-directional liquid flow with effective bi-directional sealing.
- Some models have built-in condenser sight glass to indicate the refrigerant water content, so that users can easily check the refrigerant water content.
- With the advanced algorithm "evaporator liquid level control as the primary and approach temperature difference control as the supplement", the 6386-step electronic expansion valve can respond quickly and stably.

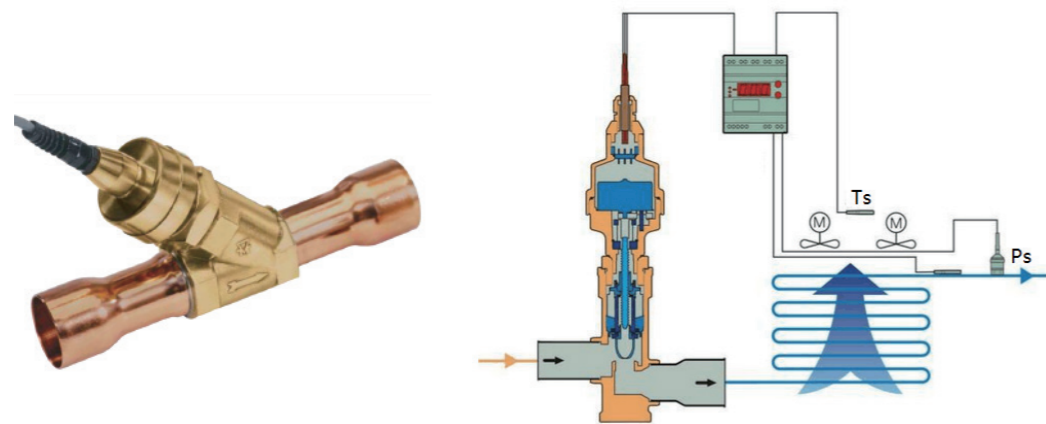

### Differential Pressure Water Flow Switch for Easier Operation

- Differential pressure water flow switch allows for more accurate flow disconnection and reset
- Factory-installed on the unit, no need for on-site hole cutting, installation and wiring by users.
- Less space required for installation
- No resistance loss produced to the water system.
- Fewer moving parts contribute to lower possibility of fatigue damage.



### Optimal Filter-drier and Oil Filter

- The unit adopts dry filter with replaceable filter element, which is convenient for maintenance.
- The filter element adopts 100% 3A molecular sieve, which has super water absorption function.
- Optimize the flow design for small pressure drop.
- Aviation-grade oil filter with high filtration precision and large filtration area.



### High-precision PT100 Platinum Temperature Sensor

- The temperature sensors are all made from PT100 platinum metal, which has high precision and with no resistance drift. The measurement accuracy is high. Also the probe part and the cable are cold crimped, and the steam-proof design is adopted to prevent moisture from entering and affecting the resistance value.
- The pressure sensor adopts current-type transmission output. The current signal has strong anti-interference ability, so the signal is stable, and the accuracy is 0.5% FS (full range).





## High Efficiency and Environmental Protection

### More Than 20% Energy-saving Compared with Conventional Units

- The Hi-SC S Series saves more than 20% energy than the conventional units, which can greatly reduce the energy consumption caused by the HVAC.
- The COP can be up to 6.102.

### Stepless Capacity from 25% to 100%

The capacity output of single compressor can achieve 25%–100% stepless adjustment, so that the capacity output can be adjusted more accurately according to user needs. Thus, the operation is more energy-saving, and the outlet water temperature is more stable.

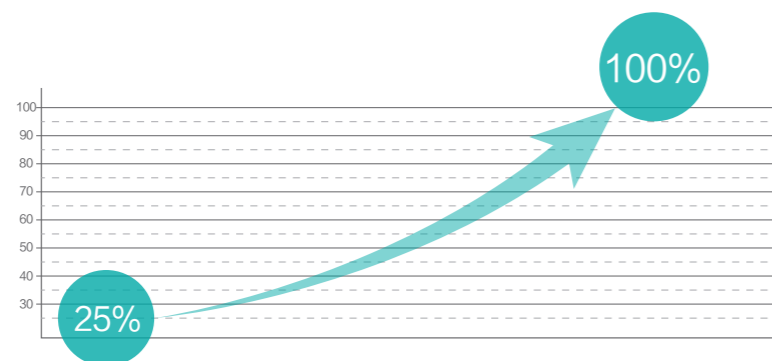

### Adaptive Control of Evaporator Liquid Level for Better Heat Exchange

Intelligent adaptive control technology of evaporator liquid level is adopted to ensure that the evaporator plays the highest heat transfer efficiency under variable working conditions and partial load condition.

### Load Limit for Energy Saving

The unit is equipped with a function of "Load Limit for Energy Saving", which can effectively reduce the operation cost.

### Environmentally Friendly Refrigerant R134a

- Environmentally friendly R134a refrigerant is non-toxic with ODP=0 and will not destruct the ozone layer.
- New system design with less refrigerant charge.
- Low energy consumption, reduced carbon emissions.



## Reliable Operation

### Intelligent Warning Technology

The unit has multiple pre-detection functions to identify and correct the operating status by real-time monitoring and analysis of the pressure, temperature, current and other parameters in time, so that the unit can work within the reliable operating range and better cope with the harsh working conditions.

### Multiple Protections

The unit has multiple protection measures, such as water anti-freeze protection, water cut-off protection, high voltage & low voltage protection, over-current protection, power supply protection, discharge temperature protection, sensor fault reminder and so on. So as to ensure the safe operation under the complex working conditions





### Advanced Compressor Control

- The compressor adopts PID control, which realizes stepless adjustment of the capacity output. For the single compressor, the adjust range is 25%–100%.

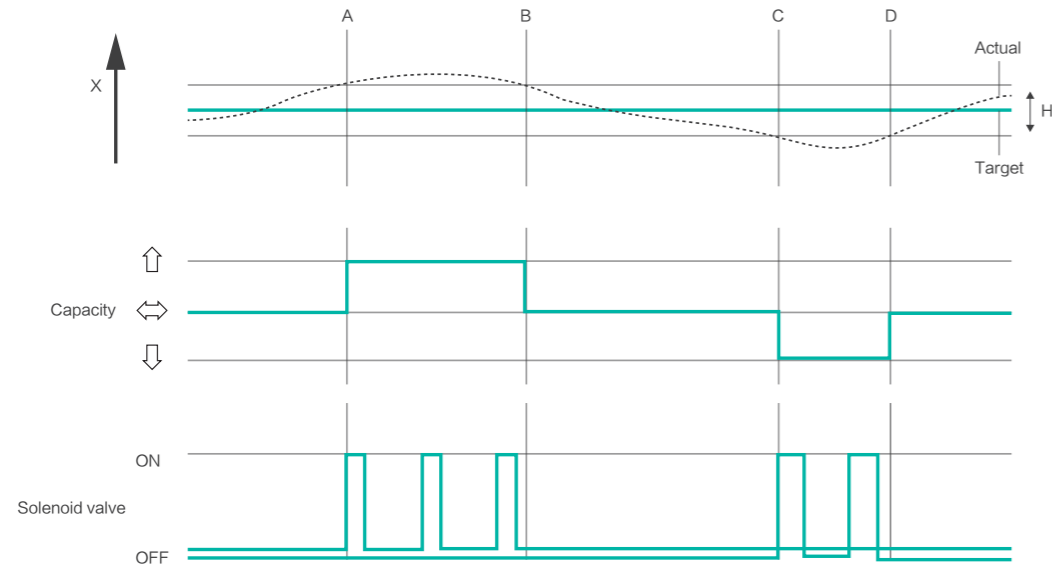

- Stabilize product operation through optimal compressor start–stop control, minimum stop interval, and shortest running time control.

### Balance the Working Time of Each Compressor

- The dual–compressor independent system design, with the two compressors as backup to each other, greatly improves the reliability of the unit.
- The rotation running time of the two compressors is intelligently balanced, effectively extending the service life.

### Simplified Installation

The water inlets and outlets of the evaporator and condenser are arranged on the same side. It is convenient for users to organize the machine room, facilitates the installation and saves the floor space.

### Memory Function When Power Off

When the unit is unexpectedly powered off, the user's default settings and historical data can still be retained, and there is no need to repeat settings.

## Intelligent Control And Smart Operation

### 7-inch Color Touch Screen

- 7-inch high–resolution color touch screen displays the operation status and parameters in graphics dynamically.
- Screen saver is available to extend the life of the screen.



- The detailed fault is displayed directly no need to check the alarm code, and the water temperature curve is displayed intuitively, easy to check the operation load.
- Set password protection to prevent unauthorized personnel from operating.

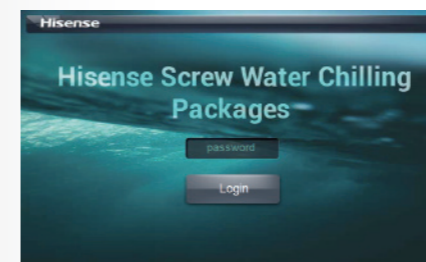

### Comprehensive and Intelligent Unit Control





# TECHNICAL PARAMETERS

## Specification

HSLGE-*/MH/AH	Unit	90S	100S	130S	150S	170S	190S	210S	230S	260D	300D	340D	390D	420D	470D	
Nominal cooling capacity	kW	322.4	366.8	446.7	511.3	587.1	666.9	721.5	801.3	919.6	1053	1209	1373	1486	1650	
Nominal cooling input power	kW	55.4	63.1	77.0	86.6	97.5	110.3	125.1	138.0	153.0	175.1	198.9	225.0	253.0	279.1	
COP	/	5.819	5.813	5.801	5.904	6.022	6.046	5.767	5.807	6.010	6.014	6.078	6.102	5.874	5.912	
IPLV	/	6.842	6.835	6.821	6.943	7.082	7.111	6.780	6.827	7.177	7.180	7.258	7.287	7.011	7.058	
Chilled water flow rate	m³/h	55.5	63.1	76.8	87.9	101.0	114.7	124.1	137.8	158.2	181.1	207.9	236.2	255.5	283.8	
Cooling water flow rate	m³/h	69.3	78.9	96.0	109.9	126.2	143.4	155.1	172.3	197.7	226.3	259.9	295.2	319.4	354.7	
Max. running current	A	139.1	159.3	187.0	212.0	234.0	272.0	303.0	335.0	374.0	424.0	468.0	544.0	606.0	670.0	
Power supply	/	AC 3Φ, 380V/50Hz														
Capacity control	/	25%~100% Stepless										12.5%~100% Stepless				
Compressor	Type	Semi-hermetic screw compressor														
	Quantity	1							2							
	Start mode	Y-Δ														
	Start current (Y)	A	280.0	330.0	415.0	479.0	506.0	650.0	683.0	845.0	602.0	691.0	740.0	922.0	986.0	1180.0
Evaporator	Type	High efficiency shell and tube type (flooded type)														
	Water connection type	Clamp														
	Outer diameter of connection pipe	mm	133	133	159	159	159	159	159	219	219	219	219	219	219	273
	Standard pressure	MPa	1.0													
	Water pressure drop	kPa	50	49	49	48	48	49	49	49	88	87	87	86	87	87
Water dirt coefficient	m²C/KW	0.018														
Condenser	Type	High efficiency shell and tube type														
	Water connection type	Clamp														
	Outer diameter of connection pipe	mm	133	133	159	159	159	159	219	219	219	219	219	273	273	273
	Standard pressure	MPa	1.0													
	Water pressure drop	kPa	68	69	66	67	67	66	67	67	106	106	108	108	106	106
Water dirt coefficient	m²C/KW	0.044														
Refrigerant	Type	R134a														
	Total charge amount	kg	125	110	140	150	180	200	215	235	295	305	350	400	430	480
Dimensions	Length	mm	3530	3530	3550	3550	3570	3570	3590	3590	4710	4710	4720	4750	4840	4840
	Width	mm	1240	1240	1320	1320	1430	1430	1520	1520	1570	1570	1660	1780	1780	1850
	Height	mm	1700	1700	1750	1750	1800	1800	1850	1850	1900	1900	1910	1960	1980	1980
Package size (including base)	Length	mm	4000	4000	4000	4000	4000	4000	4000	5100	5100	5100	5100	5100	5100	
	Width	mm	1570	1570	1570	1570	1570	1570	1570	1900	1900	1900	1900	1900	1900	
	Height	mm	1860	1860	1910	1910	1960	1960	2010	2080	2080	2090	2140	2160	2160	
Shipping weight (without refrigerant)	kg	2720	2780	3430	3510	3810	3870	4200	4330	6340	6510	6930	7480	7690	7920	
Operation weight	kg	2750	2820	3550	3650	4000	4090	4450	4620	6700	6900	7400	8080	8350	8620	

Notes:

1. Nominal cooling condition: chilled water outlet temperature 7°C, cooling water inlet temperature 30°C.

2. The standard pressure is 1.0 MPa. The 1.6 MPa or 2.0 MPa can be customized according to users' need.

### Correction Coefficient for Refrigerating Capacity under Variable Working Conditions

Evaporator Outlet Temperature	Condenser Inlet Temperature (°C)				
	25	28	30	32	35
5	1.01	0.98	0.95	0.92	0.89
6	1.04	1.01	0.97	0.95	0.91
7	1.07	1.03	1.00	0.98	0.94
8	1.11	1.07	1.03	1.02	0.98
9	1.15	1.12	1.08	1.06	1.02
10	1.19	1.16	1.11	1.09	1.05
11	1.24	1.20	1.16	1.14	1.10
12	1.29	1.25	1.20	1.18	1.14

### Correction Coefficient for Power input under Variable Working Conditions

Evaporator Outlet Temperature	Condenser Inlet Temperature (°C)				
	25	28	30	32	35
5	0.86	0.93	0.99	1.04	1.12
6	0.86	0.93	1.00	1.05	1.12
7	0.87	0.93	1.00	1.05	1.12
8	0.87	0.93	1.00	1.05	1.12
9	0.87	0.93	1.00	1.05	1.13
10	0.87	0.93	1.00	1.05	1.13
11	0.87	0.93	1.00	1.05	1.13
12	0.87	0.94	1.01	1.05	1.13

# INSTALLATION

## Cautions for Lifting and Transportation

Lifting is recommended for the transfer of Hi-SC S series, while forklift handling is strictly prohibited. Attention shall be paid to the followings.

- The unit must be lifted from the designated lifting points.
- Check the load-bearing capacity of the slings and hangers to make sure that they are adequate to lift the unit and have sufficient margin.
- Ensure that the unit is horizontal as much as possible during transporting, and that the maximum height difference of the unit's feet from the ground does not exceed 25cm, so as to prevent the unit from overturning or reversing.
- The handling of the unit should be carried out slowly, and the personnel should keep a certain distance and take safety protections to prevent collisions with surrounding objects.
- During lifting, it is strictly forbidden to press the electric cabinet, pipeline or any valves by the cable, otherwise serious damage may be caused to the unit.
- The hoisting should be in place at once as much as possible to avoid accidents caused by repeated hoisting.

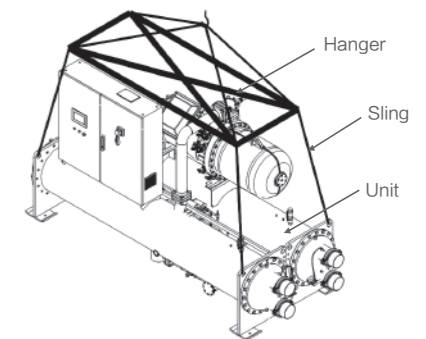

## Unit Installation

Hi-SC S series must be installed on a fixed foundation (flat and firm, and treated as water-proof) with drainage ditches around. Please pay attention to the follows when construct the foundation.

- Reinforced concrete foundation is recommended.
- It is recommended to reserve 4\* 100 × 100 anchor bolt mounting holes. If spring shock absorbers are used, no need to reserve mounting holes.
- The foundation shall be level and the maximum height difference shall be controlled within 1 mm/m.
- Drainage ditch should be set, and there should be a certain slope to facilitate drainage.
- You can refer to the following figure for the design and construction of the foundation. The dimension A, B, D, E and F should refer to the unit dimension.

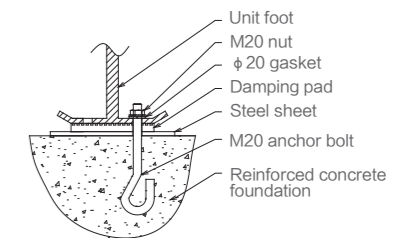

Installation of Damping pad

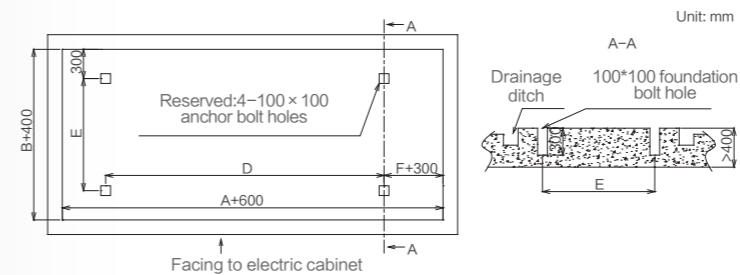

Foundation

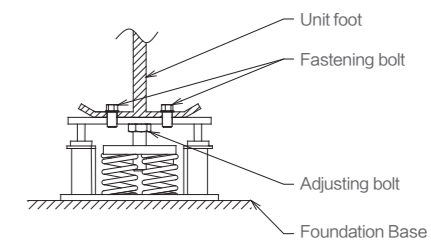

Installation of Shock Absorber



### Requirements for Installation Space and Environment

- There should be enough service space, to facilitate maintenance.
- The service space required is shown on the right.
- The space reserved in the direction of the length of the unit is to facilitate future heat exchanger cleaning and maintenance. If the machine room is limited, the location of the doorway can be effectively used as the space for heat exchange tube maintenance.
- For the installation of multiple units, it should be noted that the distance between the two units should be 1.5 times than the required distance of a single unit.
- The unit must be installed indoors. Humid areas or areas with direct sunlight shall be avoided;
- The selection of the installation location should avoid the transmission of noise and vibration from affecting the living and office areas.
- The installation location of the unit shall be provided with appropriate safeguards to avoid icing at low temperatures.

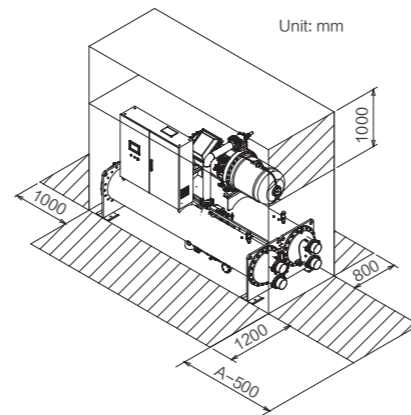

### Precautions for Design and Construction of the Water System

The high quality of design and installation of the water system plays a very important role on the operation of the unit and the comfort of the whole system. The design plan must be issued by a professionally qualified designer. When designing the plan, attention should be paid to the follows.

- The water inlet and outlet should be equipped with bypass pipelines to facilitate the flushing of the pipeline and the maintenance.
- The water pump shall be set at the water inlet side of the heat exchanger.
- If the water system adopts a closed circuit, an expansion water tank should be provided. The expansion water tank should be set at more than 1m higher than the highest point of the entire water system. The capacity of the water tank is about 1/10 of the water capacity of the entire system.
- A filter must be added at the water inlet pipeline and the filter mesh should be more than 16 meshes. The filter needs to be cleaned regularly.
- Vibration-proof soft connections should be added between the unit and the pipelines.

### Minimum Water Capacity Requirements

- The min. water capacity should meet the requirements on the right table.

Application	Minimum Water Capacity
Comfortable air conditioner	5L/kW
Process cooling	7.5L/kW

- Usually, an additional water tank needs to be added to expand the total water volume and the water tank is usually installed on the water inlet side. A baffle plate needs to be added in the water tank to avoid short circuit of the water flow. The form of the baffle plate can refer to the following forms:

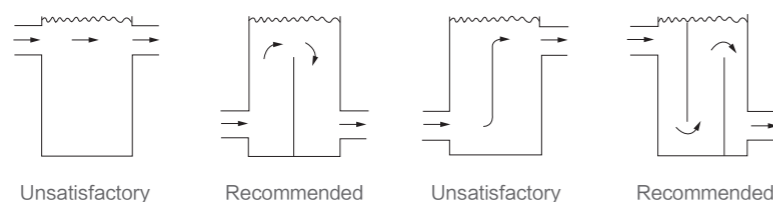

### Dimensional Drawing

#### Dimension of Single-compressor Unit

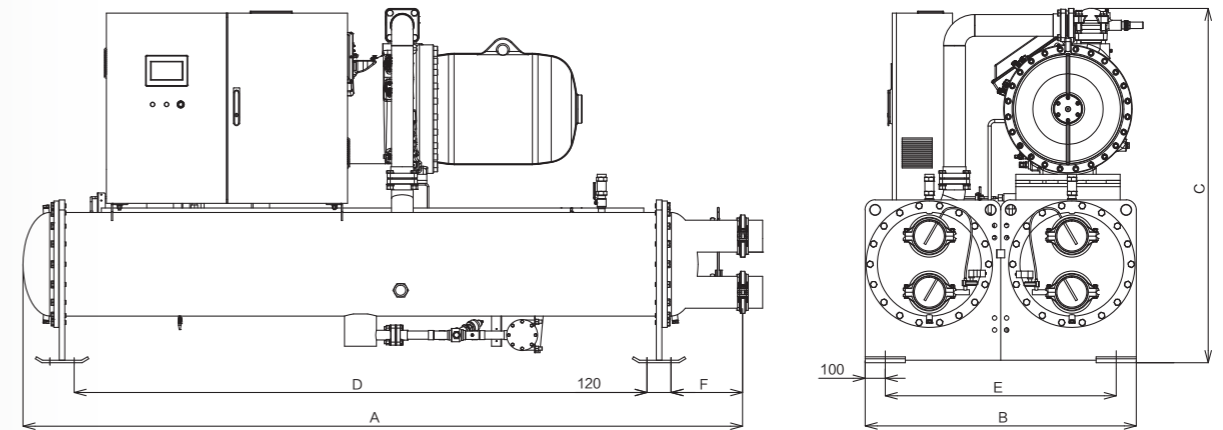

Dimension Sheet of Single-compressor Unit (Unit: mm)						
Model	A	B	C	D	E	F
HSLGE-90SMH/AH	3530	1240	1700	2852	980	308
HSLGE-100SMH/AH	3530	1240	1700	2852	980	308
HSLGE-130SMH/AH	3550	1320	1750	2852	1030	308
HSLGE-150SMH/AH	3550	1320	1750	2852	1030	308
HSLGE-170SMH/AH	3570	1430	1800	2852	1150	308
HSLGE-190SMH/AH	3570	1430	1800	2852	1150	308
HSLGE-210SMH/AH	3590	1520	1850	2852	1250	308
HSLGE-230SMH/AH	3590	1520	1850	2852	1250	308

#### Dimension of Double-compressor Unit

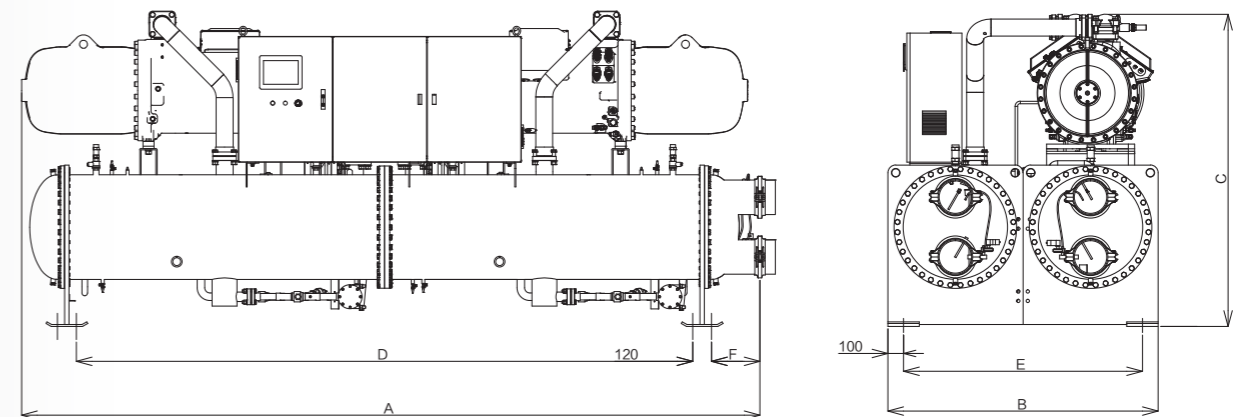

Data Sheet of Double-compressor Unit (Unit: mm)						
Model	A	B	C	D	E	F
HSLGE-260DMH/AH	4710	1570	1900	3922	1320	396
HSLGE-300DMH/AH	4710	1570	1900	3922	1320	396
HSLGE-340DMH/AH	4720	1660	1910	3922	1390	396
HSLGE-390DMH/AH	4750	1780	1960	3922	1540	396
HSLGE-420DMH/AH	4840	1780	1980	3922	1540	396
HSLGE-470DMH/AH	4840	1850	1980	3922	1600	396

# AIR HANDLING UNIT



## Features

Hisense AHU can satisfy the customers' personalized demands thanks to its compact structure, excellent performance, multiple static pressure, and wide air flow ranging from 2000 to 50000 m<sup>3</sup>/h. It adopts labyrinth internal and external frame structure with low air leakage rate, high strength. There are five types of AHU for choice: Horizontal Type I, Horizontal Type II, Horizontal Type III, Horizontal Type IV, Vertical Type I. Besides, according to the actual demand, hot water coils, wet-film humidifiers can be configured, and it is widely used in shopping malls, hotels, office buildings and other commercial buildings.

### Diagram to distinguish the left and right type of the unit

Facing the air flow, if water piping at left side indicates left type. Otherwise, right type.

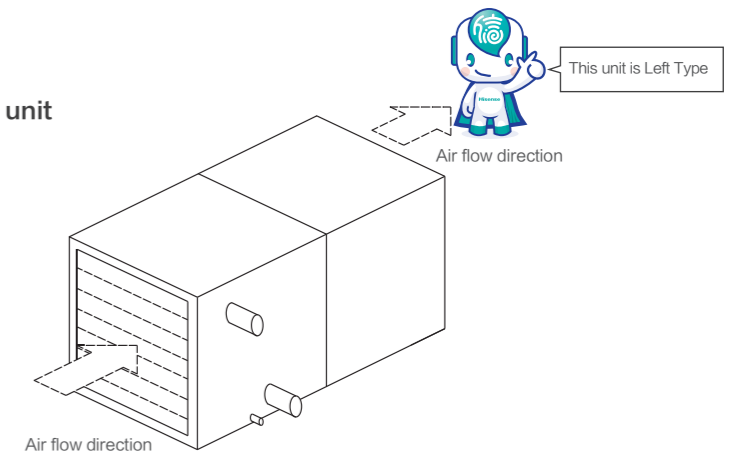

### Nomenclature

HZK	A	-02	W1	120	H	Z	4	1	F	0	A
											Serial No.: A, B, C
											Wet-film Humidifier: 0-None, 1-Thickness 50mm, 2-Thickness 100mm
											Direction of Fan Motor: F-UF R-UR T-FT B-FB
											Hot Water Coil: 1- One Row, 2- Two Rows, None-N
											Chilled Water Coil: 4-Four Rows, 6- Six Rows, None-N
											Piping Direction: Z-Left, Y-Right
											Handling Condition: H-Return Air Condition, X-Fresh Air Condition
											ESP: 120-120Pa    270-270Pa    420-420Pa    570-570Pa
											170-170Pa    320-320Pa    470-470Pa    620-620Pa
											220-220Pa    370-370Pa    520-520Pa    670-670Pa
											Type: W1- Horizontal Type I    W3- Horizontal Type III    L1- Vertical Type I
											W2- Horizontal Type II    W4- Horizontal Type IV
											Air Flow: 02-2000m <sup>3</sup> /h    03-3000m <sup>3</sup> /h    04-4000m <sup>3</sup> /h
											05-5000m <sup>3</sup> /h    06-6000m <sup>3</sup> /h    07-7000m <sup>3</sup> /h
											08-8000m <sup>3</sup> /h    09-9000m <sup>3</sup> /h    10-10500m <sup>3</sup> /h
											12-12000m <sup>3</sup> /h    13-13500m <sup>3</sup> /h    15-15000m <sup>3</sup> /h
											18-18000m <sup>3</sup> /h    21-21000m <sup>3</sup> /h    24-24000m <sup>3</sup> /h
											27-27000m <sup>3</sup> /h    30-30000m <sup>3</sup> /h    33-33000m <sup>3</sup> /h
											35-35000m <sup>3</sup> /h    40-40000m <sup>3</sup> /h    45-45000m <sup>3</sup> /h
											50-50000m <sup>3</sup> /h
											Series: A-Skin Thickness 25mm    B-Skin Thickness 50mm
											Name Code: AHU

66  
Features

68  
Specification

84  
Control System



### Labyrinth Seal Structure Design

#### Low Air Leakage Rate

It is designed with labyrinth seal structure. The aluminum profile with concave and convex grooves is adopted at the junction of housing and further fastened by bolts and nuts, forming a labyrinth sealing structure. The max. air leakage rate is only 0.27%, far lower than the internationally allowed air leakage rate.

### Firm Structure Design

The air handling unit is composed with an outer aluminum alloy frame and a concealed inner metal frame. The outer aluminum alloy frame is fastened by the tenon structure, bolts and nuts to form a torsion-resistant rigid body, while the inner concealed metal frame greatly increases the strength of the unit.

### Prevention of Cold Bridge and Rust

All metals inside the labyrinth body are isolated from the outside by means of polyurethane foam and specially designed seals, avoiding the sticking of insulation strips everywhere inside the housing as the common AHU and it simply eliminates the cold bridge problem. All panels are inlaid with aluminum profile frame on all edges so that the corners and edges of sheet metal are totally isolated from air and moisture, thereby preventing rust spot on panels.

### Integrated Seamless Water Tray With No Water Leakage

The AHU adopts the integrated water tray which is possessed by the advanced German-made spraying equipment and then pasted with the integral insulation material. It is installed on the bottom of the AHU on the full size, so that there will be no water leakage worry during operation.



Strong and Firm structure

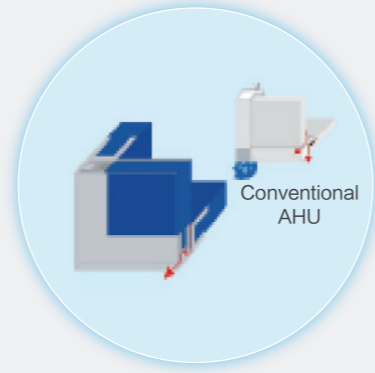

Prevention of Cold Bridge and Rust

## Specification

### Classification

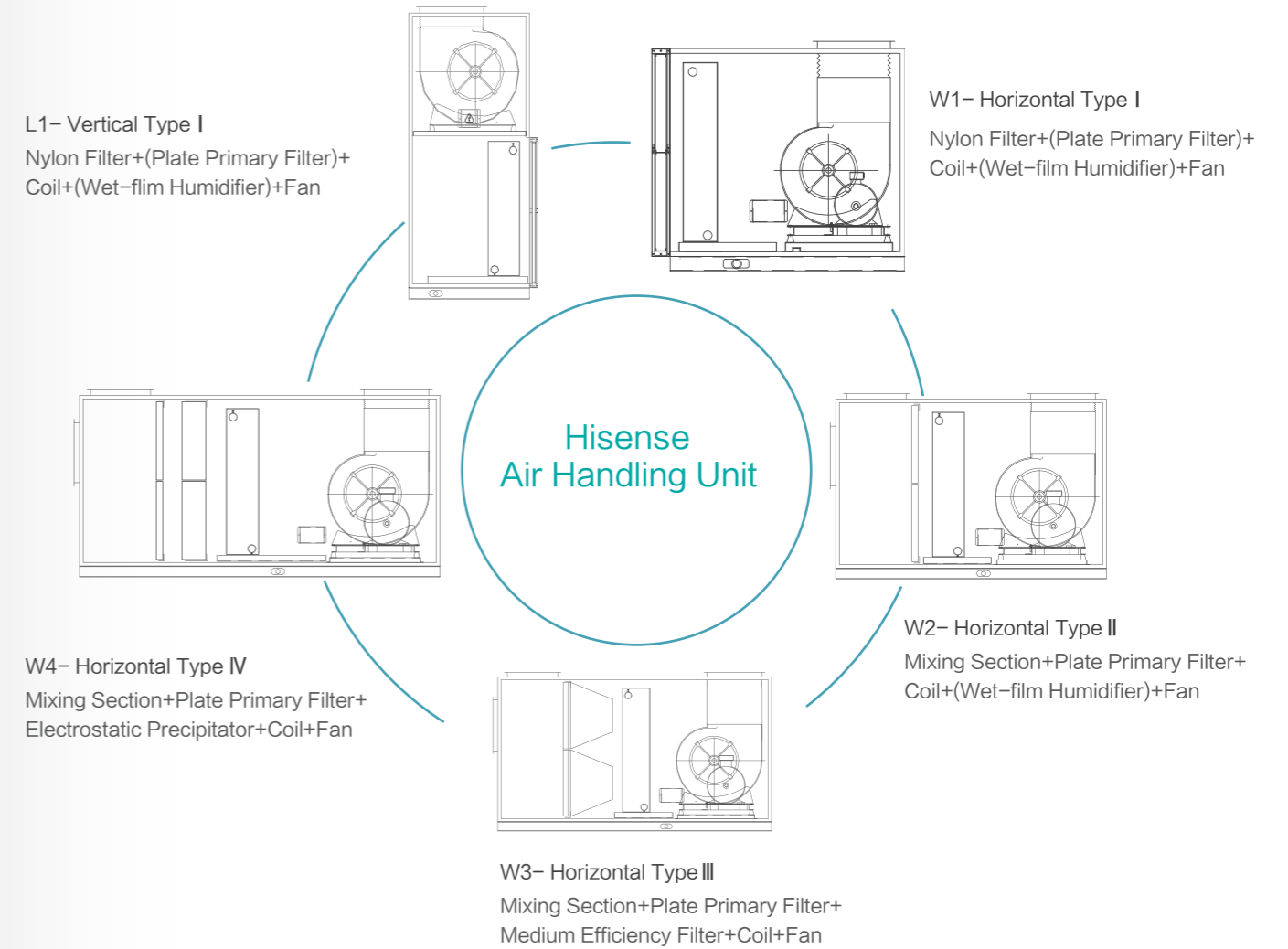

### Direction of Fan Motor

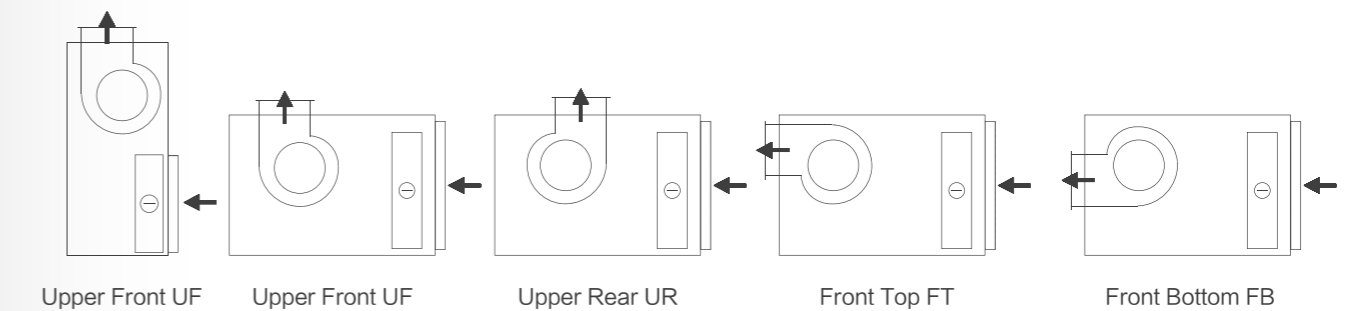



Standard Condition

Model	Air Flow	Four Rows						Six Rows						Noise
		Rated Cooling Capacity	Rated Heating Capacity	Water Flow	Water Resistance	Chilled Water Pipe Diameter	Condensate Pipe Diameter	Rated Cooling Capacity	Rated Heating Capacity	Water Flow	Water Resistance	Chilled Water Pipe Diameter	Condensate Pipe Diameter	
HZK*~*	m³/h	kW	kW	l/s	kPa	DN	DN	kW	kW	l/s	kPa	DN	DN	dB(A)
02	2000	11.0	22.8	0.5	7.5	32	25	14.8	27.6	0.7	44.8	32	25	55.0
03	3000	17.2	35.1	0.8	13.8	32	25	22.7	41.9	1.1	71.6	32	25	58.0
04	4000	23.4	47.1	1.1	20.7	32	25	29.6	54.6	1.4	34.8	32	25	59.0
05	5000	28.2	57.0	1.3	19.9	32	25	34.5	64.5	1.6	30.3	32	25	61.0
06	6000	35.1	69.1	1.7	27.0	40	25	42.4	78.2	2.0	40.3	40	25	62.0
07	7000	41.0	80.7	2.0	31.9	50	25	48.8	92.5	2.3	50.0	50	25	64.0
08	8000	48.2	93.7	2.3	46.9	50	25	57.2	106.7	2.7	74.7	50	25	64.0
09	9000	52.3	102.6	2.5	42.4	50	25	65.1	120.6	3.1	75.7	50	25	65.0
10	10500	59.7	115.7	2.8	60.0	50	25	74.2	138.1	3.5	48.8	50	25	66.0
12	12000	69.8	136.8	3.3	46.0	50	25	89.9	165.3	4.3	75.6	50	25	67.0
13	13500	79.1	158.1	3.8	20.8	65	32	104.1	187.7	5.0	39.0	65	32	68.0
15	15000	90.4	172.7	4.3	61.5	65	32	115.0	207.6	5.5	38.1	65	32	68.0
18	18000	107.0	210.8	5.1	31.8	65	32	136.4	247.2	6.5	51.2	65	32	69.0
21	21000	126.6	247.3	6.0	36.3	65	32	157.4	289.4	7.5	26.4	65	32	70.0
24	24000	148.8	285.6	7.1	53.4	65	32	181.9	332.2	8.7	37.7	65	32	71.0
27	27000	167.5	321.3	8.0	55.1	65	32	204.7	372.0	9.8	39.0	65	32	72.0
30	30000	186.1	357.0	8.9	56.8	65	32	226.1	413.4	10.8	39.8	65	32	73.0
33	33000	204.7	392.7	9.8	72.3	80	32	253.0	456.8	12.1	52.2	80	32	73.0
35	35000	220.1	416.5	10.5	85.6	80	32	271.3	486.9	12.9	61.6	80	32	73.5
40	40000	230.8	451.0	11.0	69.2	80	32	299.8	546.1	14.3	52.5	80	32	73.5
45	45000	248.1	484.8	11.8	71.5	80	32	341.1	617.2	16.3	59.8	80	32	74.0
50	50000	275.6	538.5	13.1	79.1	80	32	379.0	685.9	18.1	65.9	80	32	74.0

Note:

- Standard cooling conditions: chilled water inlet/outlet at 7/12°C; air inlet at 27°C DB/19.5°C WB.
- Standard heating conditions: hot water inlet at 60°C; air inlet at 15°C DB.
- Specifications are subject to change without prior notice.
- The noise in the table is tested based on the vertical type unit, and the value will change due to different ESP.

Fresh Air Condition

Model	Air Flow	Four Rows						Six Rows						Noise
		Rated Cooling Capacity	Rated Heating Capacity	Water Flow	Water Resistance	Chilled Water Pipe Diameter	Condensate Pipe Diameter	Rated Cooling Capacity	Rated Heating Capacity	Water Flow	Water Resistance	Chilled Water Pipe Diameter	Condensate Pipe Diameter	
HZK*~*	m³/h	kW	kW	l/s	kPa	DN	DN	kW	kW	l/s	kPa	DN	DN	dB(A)
02	2000	27.4	30.7	1.6	31.8	40	25	33.7	34.2	1.6	66.5	40	25	55.0
03	3000	40.5	44.3	1.9	44.0	40	25	47.9	48.9	2.3	89.6	40	25	58.0
04	4000	54.7	58.8	2.6	62.5	50	25	63.8	67.0	3.0	55.8	50	25	59.0
05	5000	68.4	73.8	3.3	64.3	50	25	79.8	83.9	3.8	53.5	50	25	61.0
06	6000	81.0	85.0	3.9	78.3	50	25	97.9	100.5	4.7	74.9	50	25	62.0
07	7000	89.6	95.0	4.3	40.5	65	25	115.4	116.7	5.5	31.4	65	25	64.0
08	8000	101.7	108.6	4.9	57.7	65	25	127.7	134.5	6.1	42.8	65	25	64.0
09	9000	116.8	123.5	5.6	58.5	65	25	140.5	146.7	6.7	40.7	65	25	65.0
10	10500	132.8	154.9	7.0	78.6	65	25	162.1	167.3	7.7	60.0	65	25	66.0
12	12000	157.9	175.3	7.5	82.7	65	25	193.6	196.5	9.2	89.0	65	25	67.0
13	13500	172.8	195.2	8.2	27.2	80	32	222.6	223.1	10.6	61.5	80	32	68.0
15	15000	194.7	221.3	9.3	27.8	80	32	252.6	252.3	12.0	62.8	80	32	68.0
18	18000	230.5	257.6	11.0	37.5	80	32	293.6	296.1	13.1	74.4	80	32	69.0
21	21000	276.3	303.6	13.2	28.1	80	32	331.5	336.1	13.9	78.3	80	32	70.0
24	24000	319.9	348.8	15.2	39.6	80	32	*366.2	*380.6	*12.5	*70.7	80	32	71.0
27	27000	359.9	389.7	17.1	42.6	80	32	*409.6	*428.2	*13.9	*72.4	80	32	72.0
30	30000	384.1	420.5	18.3	43.2	80	32	*455.2	*473.6	*15.5	*75.0	80	32	73.0
33	33000	445.7	482.0	21.2	59.8	80	32	*503.6	*523.3	*17.1	*96.3	80	32	73.0
35	35000	454.3	490.5	21.6	63.7	80	32	*552.5	*578.3	*15.5	*83.6	80	32	73.5
40	40000	477.1	525.2	22.7	40.3	80	32	*589.3	*622.5	*18.7	*83.5	80	32	73.5
45	45000	536.7	594.2	25.6	45.3	80	32	*647.2	*679.6	*19.3	*79.8	80	32	74.0
50	50000	605.1	663.9	28.8	51.6	80	32	*727.9	*774.6	*21.7	*89.9	80	32	74.0

Note:

- Standard cooling conditions: chilled water inlet/outlet at 7/12°C; air inlet at 35°CDB/28°CWB.
- Standard heating conditions: hot water inlet at 60°C; air inlet at 7°CDB.
- The value noted with \* indicates that the temperature difference between inlet and outlet water is more than 5°C to control the pressure drop of refrigerant pipeline.
- Specifications are subject to change without prior notice.
- The noise in the table is tested based on the vertical type unit, and the value will change due to different ESP.



Standard Condition (Four-Pipe, Additional Heat Coil)--Optional

Model	Air Flow	One Row				Two Rows			
		Rate Heating Capacity	Water Flow	Water Resistance	Water Pipe Diameter	Rate Heating Capacity	Water Flow	Water Resistance	Water Pipe Diameter
HZK*-*	m³/h	kW	l/s	kPa	DN	kW	l/s	kPa	DN
02	2000	6.7	0.2	0.2	32	13.6	0.3	1.2	32
03	3000	10.2	0.3	0.3	32	20.0	0.5	2.0	32
04	4000	13.8	0.3	0.5	32	27.2	0.7	3.0	32
05	5000	18.5	0.5	0.5	32	35.8	0.9	3.3	32
06	6000	23.2	0.6	0.7	32	43.7	1.1	4.3	32
07	7000	27.6	0.7	0.9	32	50.9	1.2	5.1	32
08	8000	32.5	0.8	1.3	32	56.8	1.4	6.4	32
09	9000	37.0	0.9	1.3	32	64.4	1.6	6.5	32
10	10500	42.0	1.0	1.8	32	77.7	1.9	10.3	32
12	12000	48.7	1.2	2.5	32	88.8	2.2	14.2	32
13	13500	56.4	1.4	3.7	40	101.5	2.5	20.4	40
15	15000	61.7	1.5	3.9	40	111.0	2.7	21.1	40
18	18000	75.2	1.8	5.4	40	135.3	3.3	29.2	40
21	21000	88.9	2.2	7.0	40	157.8	3.9	37.5	40
24	24000	103.1	2.5	10.2	40	174.7	4.3	7.7	40
27	27000	116.0	2.8	10.3	40	196.5	4.8	7.8	40
30	30000	128.8	3.1	10.4	40	216.5	5.3	7.7	40
33	33000	141.7	3.5	13.4	40	240.1	5.9	10.1	40
35	35000	150.3	3.7	15.6	40	254.7	6.2	11.7	40
40	40000	167.0	4.1	13.9	40	281.5	6.9	10.4	40
45	45000	187.9	4.6	15.3	40	322.1	7.9	11.8	40
50	50000	208.8	5.1	16.7	40	357.9	8.7	12.8	40

Note:

- Standard heating conditions: hot water inlet/outlet at 60/50°C; air inlet at 15°C DB.
- Specifications are subject to change without prior notice.

Fresh Air Condition (Four-Pipe, Additional Heat Coil)--Optional

Model	Air Flow	One Row				Two Rows			
		Rate Heating Capacity	Water Flow	Water Resistance	Water Pipe Diameter	Rate Heating Capacity	Water Flow	Water Resistance	Water Pipe Diameter
HZK*-*	m³/h	kW	l/s	kPa	DN	kW	l/s	kPa	DN
02	2000	9.0	0.2	0.3	32	16.6	0.4	1.7	32
03	3000	13.5	0.3	0.5	32	25.7	0.6	3.1	32
04	4000	18.6	0.5	0.8	32	33.2	0.8	4.2	32
05	5000	23.2	0.6	0.8	32	43.6	1.1	4.6	32
06	6000	28.7	0.7	1.0	32	50.6	1.2	5.5	32
07	7000	33.9	0.8	1.3	32	63.0	1.5	7.2	32
08	8000	39.9	1.0	1.9	32	73.1	1.8	10.5	32
09	9000	45.5	1.1	1.8	32	78.4	1.9	9.1	32
10	10500	51.6	1.3	2.5	32	92.9	2.3	14.0	32
12	12000	59.0	1.4	3.5	32	106.2	2.6	19.2	32
13	13500	69.2	1.7	5.3	40	123.3	3.0	28.4	40
15	15000	75.9	1.9	5.5	40	134.9	3.3	29.5	40
18	18000	92.3	2.3	7.6	40	161.9	3.9	39.7	40
21	21000	109.2	2.7	10.0	40	182.9	4.5	7.4	40
24	24000	124.8	3.0	14.1	40	212.4	5.2	10.7	40
27	27000	140.4	3.4	14.3	40	237.1	5.8	10.7	40
30	30000	156.0	3.8	14.4	40	261.3	6.4	10.7	40
33	33000	173.9	4.2	19.0	40	292.1	7.1	14.1	40
35	35000	184.4	4.5	22.1	40	309.8	7.6	16.4	40
40	40000	202.3	4.9	19.2	40	342.8	8.4	14.5	40
45	45000	227.6	5.6	21.2	40	385.7	9.4	16.0	40
50	50000	256.1	6.2	23.6	40	423.6	10.3	17.1	40

Note:

- Standard heating conditions: hot water inlet/outlet at 60/50°C; air inlet at 7°C DB.
- Specifications are subject to change without prior notice.



Dimension and Weight

Vertical Type I

External Slide (Nylon Filter/Plate Primary Filter)+Coil+(Wet-film Humidifier)+Fan

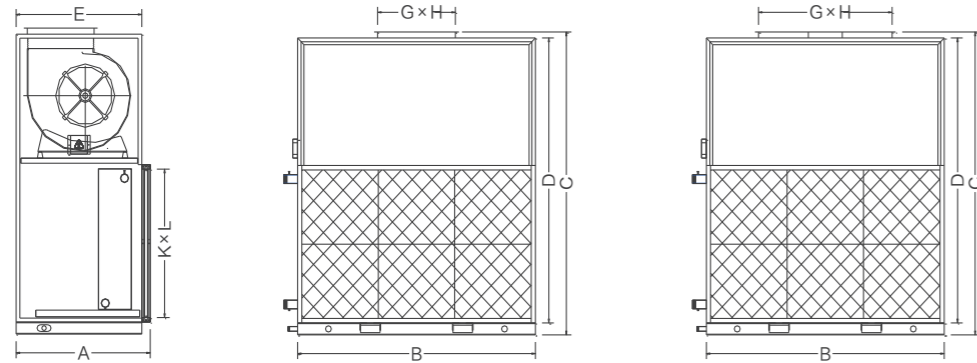

Model HZK	Dimension(mm)									Weight(kg)	
	A	B	C	D	E	G	H	K	L	4 Rows	6 Rows
02L1	640	900	1120	1000	580	232	262	840	390	137	143
03L1	640	1000	1220	1100	580	298	262	940	490	153	160
04L1	640	1100	1320	1200	580	331	289	1040	550	175	183
05L1	720	1100	1520	1400	660	309	341	1040	700	206	216
06L1	720	1200	1620	1500	660	395	341	1140	750	231	244
07L1	800	1200	1720	1600	740	373	404	1140	800	257	272
08L1	800	1400	1720	1600	740	373	404	1340	800	272	289
09L1	930	1400	1920	1800	870	430	478	1340	900	326	344
10L1	930	1600	1920	1800	870	430	478	1540	900	360	376
12L1	930	1700	1920	1800	870	557	478	1640	900	367	394
13L1	930	2000	1920	1800	870	1040	404	1940	900	481	518
15L1	930	2000	2020	1900	870	1040	404	1940	1000	491	520
18L1	960	2200	2120	2000	900	1203	478	2140	1050	570	611
21L1	960	2500	2120	2000	900	1203	478	2440	1050	631	673
24L1	960	2800	2220	2100	900	1572	478	2740	1150	682	730
27L1	960	2800	2320	2200	900	1572	478	2740	1200	735	789
30L1	960	2800	2420	2300	900	1572	478	2740	1350	786	845
33L1	1060	3100	2420	2300	1100	1588	569	3040	1300	952	1018
35L1	1160	3200	2520	2400	1100	1776	638	3140	1300	1020	1089
40L1	1160	3400	2620	2500	1100	1776	638	3340	1400	1067	1181
45L1	1160	3600	2720	2600	1100	1776	638	3540	1500	1112	1129
50L1	1160	3800	2720	2600	1100	1776	638	3740	1500	1194	1330

- Note:
- If the plate primary filter is adopted, the size of A need to be increased by 40mm.
  - The dimensions in the above table is for the units of HZKA series whose skin thickness is 25mm. And for the units of HZKB series whose skin thickness is 50mm, the extra dimension of 25mm should be added accordingly.

Horizontal Type I

External Slide Filter+(Plate Primary Filter)+Coil+(Wet-film Humidifier)+Fan

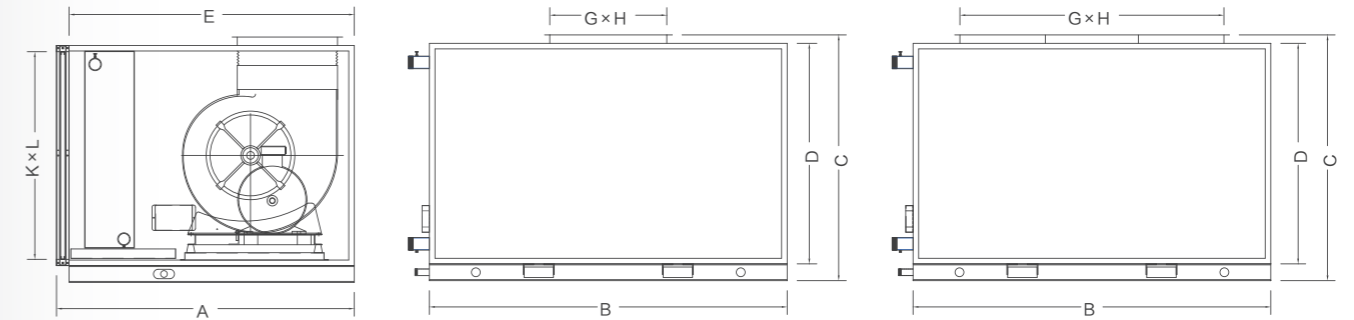

Model HZK	Dimension(mm)									Weight(kg)	
	A	B	C	D	E	G	H	K	L	4 Rows	6 Rows
02W1	1060	853	690	570	1000	232	262	793	510	129	138
03W1	1160	953	720	600	1100	298	262	893	540	148	155
04W1	1160	1053	790	670	1100	331	289	993	610	167	175
05W1	1160	1053	920	800	1100	309	341	993	740	186	197
06W1	1160	1153	990	870	1100	395	341	1093	810	211	223
07W1	1260	1203	1070	950	1200	373	404	1143	890	242	257
08W1	1260	1353	1070	950	1200	373	404	1293	890	256	282
09W1	1410	1353	1170	1050	1350	430	478	1293	990	299	318
10W1	1410	1553	1170	1050	1350	430	478	1493	990	325	342
12W1	1460	1703	1170	1050	1400	557	478	1643	990	350	376
13W1	1360	1953	1170	1050	1300	1040	404	1893	990	442	459
15W1	1360	1953	1270	1150	1300	1040	404	1893	1090	447	470
18W1	1510	2153	1320	1200	1450	1203	478	2093	1140	539	580
21W1	1510	2353	1370	1250	1450	1203	478	2293	1190	584	626
24W1	1510	2653	1390	1250	1450	1572	478	2593	1190	644	692
27W1	1510	2653	1520	1380	1450	1572	478	2593	1320	728	781
30W1	1560	2653	1640	1500	1500	1572	478	2593	1440	761	813
33W1	1610	2903	1640	1500	1550	1588	569	2843	1440	882	947
35W1	1710	3053	1640	1500	1650	1776	638	2993	1440	953	1022
40W1	1760	3053	1893	1753	1700	1776	638	2993	1693	986	1099
45W1	1760	3053	2020	1880	1700	1776	638	2993	1820	1070	1187
50W1	1760	3153	2150	2010	1700	1776	638	3093	1950	1097	1231

- Note:
- If the plate primary filter is adopted, the size of A need to be increased by 40mm.
  - If the air flow of the unit is horizontal, the size of C should be reduced by 40mm.
  - The dimensions in the above table is for the units of HZKA series whose skin thickness is 25mm. And for the units of HZKB series whose skin thickness is 50mm, the extra dimension of 25mm should be added accordingly.



### Horizontal Type II

Mixing Section+Plate Primary Filter+Coil+(Wet-film Humidifier)+Fan

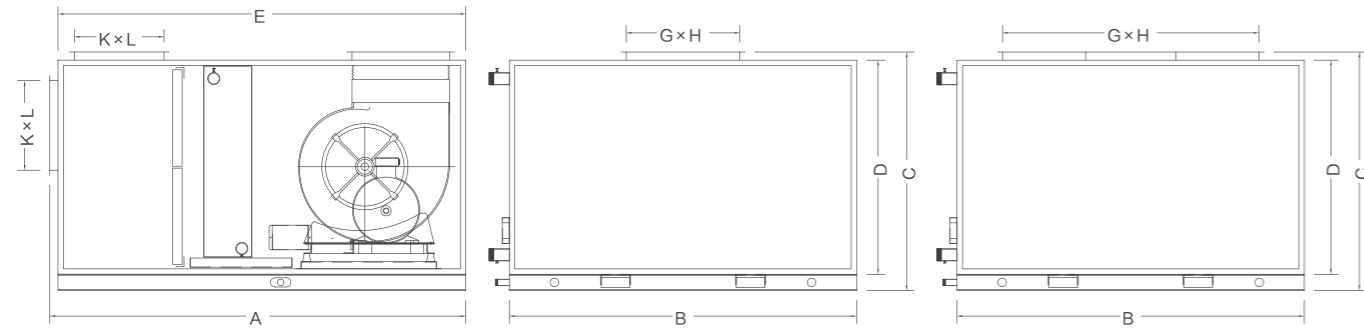

Model HZK	Dimension(mm)									Weight(kg)	
	A	B	C	D	E	G	H	K	L	4 Rows	6 Rows
02W2	1540	853	690	570	1500	232	262	600	160	158	164
03W2	1640	953	720	600	1600	298	262	600	300	177	184
04W2	1640	1053	790	670	1600	331	289	700	300	201	208
05W2	1640	1053	920	800	1600	309	341	800	300	230	240
06W2	1640	1153	990	870	1600	395	341	900	300	261	274
07W2	1740	1203	1070	950	1700	373	404	1000	300	288	303
08W2	1740	1353	1070	950	1700	373	404	1100	300	319	335
09W2	1990	1353	1170	1050	1950	430	478	1000	440	343	362
10W2	1990	1553	1170	1050	1950	430	478	1100	440	392	408
12W2	2040	1703	1170	1050	2000	557	478	1200	440	426	452
13W2	1940	1953	1170	1050	1900	1040	404	1300	440	525	554
15W2	1940	1953	1270	1150	1900	1040	404	1500	440	569	597
18W2	2090	2153	1320	1200	2050	1203	478	1700	440	652	693
21W2	2090	2353	1370	1250	2050	1203	478	1900	440	707	750
24W2	2090	2653	1390	1250	2050	1572	478	2200	440	780	829
27W2	2290	2653	1520	1380	2250	1572	478	2200	580	912	965
30W2	2340	2653	1640	1500	2300	1572	478	2300	580	958	1017
33W2	2390	2903	1640	1500	2350	1588	569	2400	580	1084	1149
35W2	2490	3053	1640	1500	2450	1776	638	2400	580	1170	1239
40W2	2540	3053	1893	1753	2500	1776	638	2600	580	1202	1315
45W2	2540	3053	2020	1880	2500	1776	638	2800	580	1285	1403
50W2	2640	3153	2150	2010	2600	1776	638	2800	630	1324	1459

Note:  
1. The dimensions in the above table is for the units of HZKA series whose skin thickness is 25mm. And for the units of HZKB series whose skin thickness is 50mm, the extra dimension of 25mm should be added accordingly.  
2. The units with air flow more than or equal to 4000m<sup>3</sup>/h has two surface air coolers.

### Horizontal Type III

Mixing Section+Plate Primary Filter+Medium Efficiency Filter+Coil+Fan

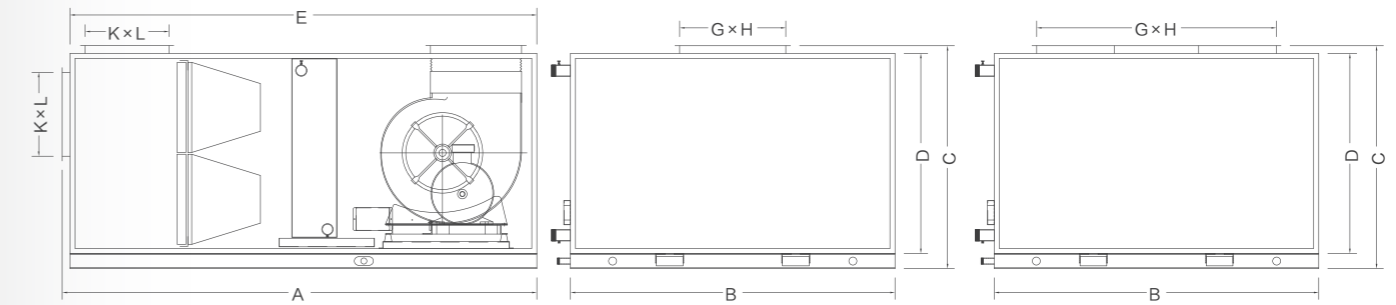

Model HZK	Dimension(mm)									Weight(kg)	
	A	B	C	D	E	G	H	K	L	4 Rows	6 Rows
02W3	1990	853	690	570	1950	232	262	600	160	176	181
03W3	2040	953	720	600	2000	298	262	600	300	197	201
04W3	2090	1053	790	670	2050	331	289	700	300	224	232
05W3	2090	1053	920	800	2050	309	341	800	300	249	259
06W3	2090	1153	990	870	2050	395	341	900	300	282	295
07W3	2190	1203	1070	950	2150	373	404	1000	300	310	324
08W3	2190	1353	1070	950	2150	373	404	1100	300	345	362
09W3	2440	1353	1170	1050	2400	430	478	1000	440	394	412
10W3	2440	1553	1170	1050	2400	430	478	1100	440	433	450
12W3	2490	1703	1170	1050	2450	557	478	1200	440	471	494
13W3	2390	1953	1170	1050	2350	1040	404	1300	440	574	598
15W3	2390	1953	1270	1150	2350	1040	404	1500	440	622	645
18W3	2540	2153	1320	1200	2500	1203	478	1700	440	727	759
21W3	2540	2353	1370	1250	2500	1203	478	1900	440	809	842
24W3	2540	2653	1390	1250	2500	1572	478	2200	440	885	922
27W3	2740	2653	1520	1380	2700	1572	478	2200	580	978	1022
30W3	2790	2653	1640	1500	2750	1572	478	2300	580	1033	1092
33W3	2840	2903	1640	1500	2800	1588	569	2400	580	1185	1250
35W3	2940	3053	1640	1500	2900	1776	638	2400	580	1246	1316
40W3	2940	3053	1893	1753	2900	1776	638	2600	580	1306	1400
45W3	2940	3053	2020	1880	2900	1776	638	2800	580	1421	1539
50W3	3040	3153	2150	2010	3000	1776	638	2800	630	1462	1597

Note:  
1. The dimensions in the above table is for the units of HZKA series whose skin thickness is 25mm. And for the units of HZKB series whose skin thickness is 50mm, the extra dimension of 25mm should be added accordingly.  
2. The units with air flow more than or equal to 4000m<sup>3</sup>/h has two surface air coolers.



Horizontal Type IV

Mixing Section+Plate Primary Filter+Electrostatic Precipitator+Coil+Fan

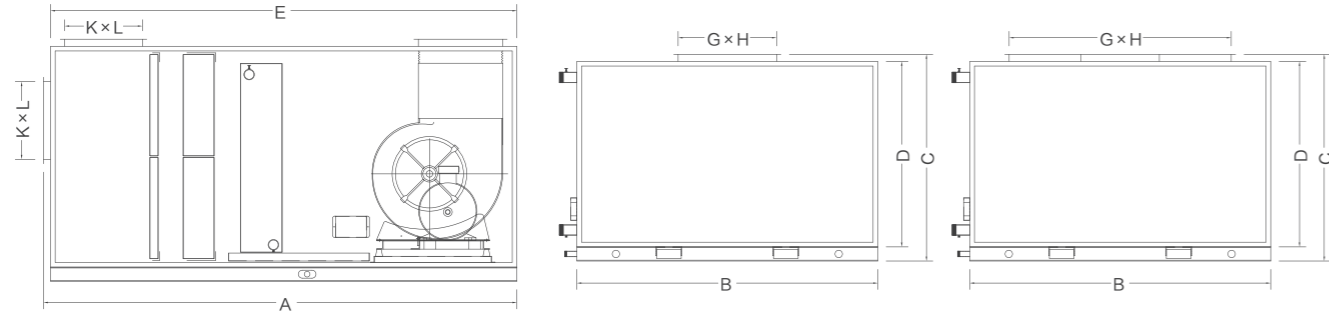

Model HZK	Dimension(mm)									Weight(kg)	
	A	B	C	D	E	G	H	K	L	4 Rows	6 Rows
02W4	1990	853	720	600	1950	232	262	600	160	188	193
03W4	2040	953	790	670	2000	298	262	600	300	215	219
04W4	2090	1113	790	670	2050	331	289	700	300	254	262
05W4	2090	1113	920	800	2050	309	341	800	300	279	289
06W4	2090	1153	990	870	2050	395	341	900	300	312	325
07W4	2190	1203	1170	1050	2150	373	404	1000	300	352	366
08W4	2190	1353	1170	1050	2150	373	404	1100	300	387	404
09W4	2440	1453	1170	1050	2400	430	478	1000	440	442	460
10W4	2440	1553	1170	1050	2400	430	478	1100	440	493	510
12W4	2490	1703	1170	1050	2450	557	478	1200	440	531	554
13W4	2390	1953	1170	1050	2350	1040	404	1300	440	646	670
15W4	2390	2103	1270	1150	2350	1040	404	1500	440	712	735
18W4	2540	2153	1320	1200	2500	1203	478	1700	440	817	849
21W4	2540	2353	1420	1300	2500	1203	478	1900	440	917	950
24W4	2540	2653	1440	1300	2500	1572	478	2200	440	1005	1042
27W4	2740	2653	1520	1380	2700	1572	478	2200	580	1110	1154
30W4	2790	2803	1640	1500	2750	1572	478	2300	580	1177	1236
33W4	2840	2903	1640	1500	2800	1588	569	2400	580	1329	1394
35W4	2940	3153	1640	1500	2900	1776	638	2400	580	1414	1484
40W4	2940	3053	1893	1753	2900	1776	638	2600	580	1498	1592
45W4	2940	3053	2043	1903	2900	1776	638	2800	580	1637	1755
50W4	3040	3153	2150	2010	3000	1776	638	2800	680	1714	1849

- Note:
- The dimensions in the above table is for the units of HZKA series whose skin thickness is 25mm. And for the units of HZKB series whose skin thickness is 50mm, the extra dimension of 25mm should be added accordingly.
  - The units with air flow more than or equal to 4000m<sup>3</sup>/h has two surface air coolers.

Power Input Under Different ESP

Vertical Type I

Model HZK	Air Flow (m <sup>3</sup> /h)	Rows of Heat Exchanger	Power Input (kW) Under Certain ESP (Pa)											
			120	170	220	270	320	370	420	470	520	570	620	
02L1	2000	4	0.55	0.55	0.55	0.55	0.55							
		6	0.55	0.55	0.55	0.55	0.75							
03L1	3000	4	0.55	0.75	0.75	0.75	1.1							
		6	0.75	0.75	0.75	1.1	1.1							
04L1	4000	4	1.1	1.1	1.1	1.1	1.5							
		6	1.1	1.1	1.1	1.1	1.5	1.5						
05L1	5000	4	1.1	1.1	1.1	1.5	1.5	1.5						
		6	1.1	1.1	1.5	1.5	1.5	1.5						
06L1	6000	4	1.5	1.5	1.5	2.2	2.2	2.2						
		6	1.5	1.5	2.2	2.2	2.2	2.2						
07L1	7000	4	1.5	1.5	1.5	2.2	2.2	2.2	2.2					
		6	1.5	1.5	2.2	2.2	2.2	2.2	2.2					
08L1	8000	4	2.2	2.2	2.2	2.2	2.2	3.0	3.0					
		6	2.2	2.2	2.2	2.2	3.0	3.0	3.0					
09L1	9000	4	2.2	2.2	2.2	2.2	3.0	3.0	3.0					
		6	2.2	2.2	2.2	3.0	3.0	3.0	3.0					
10L1	10500	4	2.2	3.0	3.0	3.0	3.0	3.0	4.0					
		6	3.0	3.0	3.0	3.0	3.0	4.0	4.0					
12L1	12000	4	2.2	3.0	3.0	3.0	3.0	4.0	4.0	4.0				
		6	3.0	3.0	3.0	3.0	4.0	4.0	4.0	4.0	5.5			
13L1	13500	4	3.0	3.0	3.0	4.0	4.0	4.0	4.0	5.5	5.5			
		6	3.0	3.0	4.0	4.0	4.0	4.0	5.5	5.5	5.5			
15L1	15000	4	3.0	4.0	4.0	4.0	5.5	5.5	5.5	5.5	5.5			
		6	4.0	4.0	4.0	5.5	5.5	5.5	5.5	5.5	7.5			
18L1	18000	4			5.5	5.5	5.5	5.5	7.5	7.5	7.5			
		6			5.5	5.5	5.5	7.5	7.5	7.5	7.5			
21L1	21000	4			5.5	7.5	7.5	7.5	7.5	11.0	11.0			
		6			7.5	7.5	7.5	7.5	11.0	11.0	11.0			
24L1	24000	4			5.5	7.5	7.5	7.5	11.0	11.0	11.0	11.0		
		6			7.5	7.5	7.5	11.0	11.0	11.0	11.0	11.0		
27L1	27000	4			7.5	7.5	11.0	11.0	11.0	11.0	11.0	11.0	15.0	
		6			7.5	11.0	11.0	11.0	11.0	11.0	11.0	11.0	15.0	15.0
30L1	30000	4			11.0	11.0	11.0	11.0	11.0	15.0	15.0	15.0	15.0	
		6			11.0	11.0	11.0	11.0	15.0	15.0	15.0	15.0	15.0	
33L1	33000	4			11.0	11.0	11.0	11.0	15.0	15.0	15.0	15.0	15.0	
		6			11.0	11.0	11.0	15.0	15.0	15.0	15.0	15.0	15.0	
35L1	35000	4			11.0	11.0	15.0	11.0	11.0	15.0	15.0	15.0	15.0	
		6			11.0	11.0	11.0	11.0	15.0	15.0	15.0	15.0	15.0	
40L1	40000	4				11.0	15.0	15.0	15.0	15.0	15.0	18.5	18.5	
		6				15.0	15.0	15.0	15.0	15.0	15.0	18.5	18.5	18.5
45L1	45000	4				15.0	15.0	15.0	18.5	18.5	18.5	18.5	22.0	
		6				15.0	15.0	18.5	18.5	18.5	18.5	22.0	22.0	22.0
50L1	50000	4				18.5	18.5	18.5	22.0	22.0	22.0			
		6				18.5	18.5	22.0	22.0	22.0				



Horizontal Type I

Model HZK	Air Flow (m³/h)	Rows of Heat Exchanger	Power Input (kW) Under Certain ESP (Pa)								
			170	220	270	320	370	420	470	520	570
02W1	2000	4	0.55	0.55	0.55	0.55	0.75				
		6	0.55	0.55	0.55	0.75	0.75				
03W1	3000	4	0.75	0.75	0.75	1.1	1.1				
		6	0.75	0.75	1.1	1.1	1.1				
04W1	4000	4	1.1	1.1	1.1	1.1	1.5				
		6	1.1	1.1	1.1	1.5	1.5				
05W1	5000	4		1.1	1.5	1.5	1.5	1.5	2.2		
		6		1.5	1.5	1.5	1.5	2.2	2.2		
06W1	6000	4		1.5	2.2	2.2	2.2	2.2	2.2		
		6		2.2	2.2	2.2	2.2	2.2	3.0		
07W1	7000	4		1.5	2.2	2.2	2.2	2.2	2.2		
		6		2.2	2.2	2.2	2.2	2.2	3.0		
08W1	8000	4		2.2	2.2	2.2	3.0	3.0	3.0		
		6		2.2	2.2	3.0	3.0	3.0	3.0		
09W1	9000	4		2.2	2.2	3.0	3.0	3.0	3.0		
		6		2.2	3.0	3.0	3.0	3.0	4.0		
10W1	10500	4		3.0	3.0	3.0	3.0	4.0	4.0		
		6		3.0	3.0	3.0	4.0	4.0	4.0		
12W1	12000	4		3.0	3.0	3.0	4.0	4.0	4.0		
		6		3.0	3.0	4.0	4.0	4.0	4.0		
13W1	13500	4		3.0	4.0	4.0	4.0	4.0	5.5		
		6		4.0	4.0	4.0	4.0	5.5	5.5		
15W1	15000	4		4.0	4.0	5.5	5.5	5.5	5.5	5.5	
		6		4.0	5.5	5.5	5.5	5.5	5.5	7.5	
18W1	18000	4		5.5	5.5	5.5	5.5	7.5	7.5	7.5	
		6		5.5	5.5	5.5	7.5	7.5	7.5	7.5	
21W1	21000	4		5.5	7.5	7.5	7.5	7.5	11.0	11.0	
		6		7.5	7.5	7.5	7.5	11.0	11.0	11.0	
24W1	24000	4		5.5	7.5	7.5	7.5	11.0	11.0	11.0	
		6		7.5	7.5	7.5	11.0	11.0	11.0	11.0	
27W1	27000	4		7.5	7.5	11.0	11.0	11.0	11.0	11.0	11.0
		6		7.5	11.0	11.0	11.0	11.0	11.0	11.0	15.0
30W1	30000	4		11.0	11.0	11.0	11.0	11.0	15.0	15.0	15.0
		6		11.0	11.0	11.0	11.0	15.0	15.0	15.0	15.0
33W1	33000	4				11.0	11.0	15.0	15.0	15.0	
		6				11.0	15.0	15.0	15.0	15.0	
35W1	35000	4				11.0	11.0	11.0	15.0	15.0	
		6				11.0	11.0	15.0	15.0	15.0	
40W1	40000	4				15.0	15.0	15.0	15.0	15.0	
		6				15.0	15.0	15.0	15.0	18.5	
45W1	45000	4				15.0	15.0	18.5	18.5	18.5	
		6				15.0	18.5	18.5	18.5	18.5	
50W1	50000	4				18.5	18.5	22.0	22.0	22.0	
		6				18.5	22.0	22.0	22.0		

Horizontal Type II

Model HZK	Air Flow (m³/h)	Rows of Heat Exchanger	Power Input (kW) Under Certain ESP (Pa)								
			170	220	270	320	370	420	470	520	570
02W2	2000	4	0.55	0.55	0.75	0.75	0.75				
		6	0.55	0.75	0.75	0.75	0.75				
03W2	3000	4	0.75	0.75	1.1	1.1	1.1				
		6	0.75	1.1	1.1	1.1	1.1				
04W2	4000	4	1.1	1.1	1.1	1.5	1.5				
		6	1.1	1.1	1.5	1.5	1.5				
05W2	5000	4	1.1	1.5	1.5	1.5	1.5				
		6	1.5	1.5	1.5	1.5	2.2				
06W2	6000	4	1.5	2.2	2.2	2.2	2.2	2.2			
		6	2.2	2.2	2.2	2.2	2.2	3.0			
07W2	7000	4	1.5	2.2	2.2	2.2	2.2	2.2			
		6	2.2	2.2	2.2	2.2	2.2	3.0			
08W2	8000	4		2.2	2.2	3.0	3.0	3.0	3.0		
		6		2.2	3.0	3.0	3.0	3.0	3.0		
09W2	9000	4		2.2	3.0	3.0	3.0	3.0	4.0		
		6		3.0	3.0	3.0	3.0	4.0	4.0		
10W2	10500	4		3.0	3.0	4.0	4.0	4.0	4.0		
		6		3.0	4.0	4.0	4.0	4.0	4.0		
12W2	12000	4		3.0	3.0	4.0	4.0	4.0	5.5		
		6		3.0	4.0	4.0	4.0	5.5	5.5		
13W2	13500	4		4.0	4.0	4.0	4.0	5.5	5.5		
		6		4.0	4.0	4.0	5.5	5.5	5.5		
15W2	15000	4			5.5	5.5	5.5	5.5	5.5	7.5	
		6			5.5	5.5	5.5	5.5	7.5	7.5	
18W2	18000	4			5.5	5.5	7.5	7.5	7.5	7.5	
		6			5.5	7.5	7.5	7.5	7.5	7.5	
21W2	21000	4			7.5	7.5	7.5	11.0	11.0	11.0	
		6			7.5	7.5	11.0	11.0	11.0	11.0	
24W2	24000	4				7.5	11.0	11.0	11.0	11.0	
		6				11.0	11.0	11.0	11.0	11.0	
27W2	27000	4				11.0	11.0	11.0	11.0	11.0	
		6				11.0	11.0	11.0	11.0	15.0	
30W2	30000	4				11.0	11.0	15.0	15.0	15.0	
		6				11.0	15.0	15.0	15.0	15.0	
33W2	33000	4				11.0	15.0	15.0	15.0	15.0	15.0
		6				15.0	15.0	15.0	15.0	15.0	15.0
35W2	35000	4				11.0	15.0	15.0	15.0	15.0	15.0
		6				15.0	15.0	15.0	15.0	15.0	15.0
40W2	40000	4					15.0	15.0	15.0	18.5	18.5
		6					15.0	15.0	18.5	18.5	18.5
45W2	45000	4					18.5	18.5	18.5	18.5	22.0
		6					18.5	18.5	18.5	22.0	22.0
50W2	50000	4					22.0	22.0	22.0		
		6					22.0	22.0			



Horizontal Type III

Model HZK	Air Flow (m³/h)	Rows of Heat Exchanger	Power Input (kW) Under Certain ESP (Pa)								
			120	170	220	270	320	370	420	470	520
02W3	2000	4	0.55	0.75	0.75	0.75	0.75	1.1	1.1	1.1	
		6	0.75	0.75	0.75	0.75	1.1	1.1	1.1	1.1	
03W3	3000	4	0.75	1.1	1.1	1.1	1.1	1.1	1.5	1.5	
		6	1.1	1.1	1.1	1.1	1.1	1.5	1.5		
04W3	4000	4	1.1	1.1	1.5	1.5	1.5	2.2	2.2	2.2	
		6	1.1	1.5	1.5	1.5	2.2	2.2	2.2	2.2	
05W3	5000	4	1.5	1.5	1.5	1.5	2.2	2.2	2.2	2.2	
		6	1.5	1.5	1.5	2.2	2.2	2.2	2.2	2.2	
06W3	6000	4	2.2	2.2	2.2	2.2	2.2	3.0	3.0	3.0	
		6	2.2	2.2	2.2	2.2	3.0	3.0	3.0		
07W3	7000	4		2.2	2.2	2.2	2.2	3.0	3.0	3.0	
		6		2.2	2.2	2.2	3.0	3.0	3.0	3.0	
08W3	8000	4		2.2	3.0	3.0	3.0	3.0	3.0	4.0	
		6		3.0	3.0	3.0	3.0	3.0	4.0	4.0	
09W3	9000	4				3.0	3.0	4.0	4.0	4.0	
		6				3.0	4.0	4.0	4.0	4.0	
10W3	10500	4				4.0	4.0	4.0	4.0	5.5	
		6				4.0	4.0	4.0	5.5	5.5	
12W3	12000	4				4.0	4.0	5.5	5.5	5.5	
		6				4.0	5.5	5.5	5.5	5.5	
13W3	13500	4				4.0	5.5	5.5	5.5	5.5	
		6				5.5	5.5	5.5	5.5	7.5	
15W3	15000	4				5.5	5.5	5.5	7.5	7.5	
		6				5.5	5.5	7.5	7.5	7.5	
18W3	18000	4				7.5	7.5	7.5	7.5	7.5	
		6				7.5	7.5	7.5	7.5	11.0	
21W3	21000	4				7.5	11.0	11.0	11.0	11.0	
		6				11.0	11.0	11.0	11.0	11.0	
24W3	24000	4				11.0	11.0	11.0	11.0	11.0	
		6				11.0	11.0	11.0	11.0		
27W3	27000	4				11.0	11.0	11.0	11.0	15.0	
		6				11.0	11.0	11.0	15.0	15.0	
30W3	30000	4				11.0	15.0	15.0	15.0	15.0	
		6				15.0	15.0	15.0	15.0		
33W3	33000	4				15.0	15.0	15.0	15.0	15.0	15.0
		6				15.0	15.0	15.0	15.0	15.0	18.5
35W3	35000	4				15.0	15.0	15.0	15.0	15.0	15.0
		6				15.0	15.0	15.0	15.0	15.0	18.5
40W3	40000	4				15.0	15.0	15.0	18.5	18.5	18.5
		6				15.0	15.0	18.5	18.5	18.5	18.5
45W3	45000	4				18.5	18.5	18.5	18.5	22.0	22.0
		6				18.5	18.5	18.5	22.0	22.0	
50W3	50000	4				22.0	22.0	22.0			
		6				22.0	22.0				

Horizontal Type IV

Model HZK	Air Flow (m³/h)	Rows of Heat Exchanger	Power Input (kW) Under Certain ESP (Pa)										
			140	190	240	290	340	390	440	490	540		
02W4	2000	4	0.55	0.55	0.75	0.75	0.75						
		6	0.55	0.75	0.75	0.75	0.75						
03W4	3000	4	0.75	0.75	1.1	1.1	1.1						
		6	0.75	1.1	1.1	1.1	1.1						
04W4	4000	4	1.1	1.1	1.1	1.5	1.5						
		6	1.1	1.1	1.5	1.5	1.5						
05W4	5000	4	1.1	1.5	1.5	1.5	1.5						
		6	1.5	1.5	1.5	1.5	2.2						
06W4	6000	4	1.5	2.2	2.2	2.2	2.2	2.2					
		6	2.2	2.2	2.2	2.2	2.2	3.0					
07W4	7000	4	1.5	2.2	2.2	2.2	2.2	2.2					
		6	2.2	2.2	2.2	2.2	2.2	3.0					
08W4	8000	4		2.2	2.2	3.0	3.0	3.0	3.0				
		6		2.2	3.0	3.0	3.0	3.0	3.0	3.0			
09W4	9000	4		2.2	3.0	3.0	3.0	3.0	3.0	4.0			
		6		3.0	3.0	3.0	3.0	4.0	4.0	4.0			
10W4	10500	4		3.0	3.0	4.0	4.0	4.0	4.0	4.0			
		6		3.0	4.0	4.0	4.0	4.0	4.0	4.0			
12W4	12000	4		3.0	3.0	4.0	4.0	4.0	4.0	5.5			
		6		3.0	4.0	4.0	4.0	4.0	5.5	5.5			
13W4	13500	4		4.0	4.0	4.0	4.0	4.0	5.5	5.5			
		6		4.0	4.0	4.0	5.5	5.5	5.5	5.5			
15W4	15000	4			5.5	5.5	5.5	5.5	5.5	5.5	7.5		
		6			5.5	5.5	5.5	5.5	5.5	7.5	7.5		
18W4	18000	4			5.5	5.5	7.5	7.5	7.5	7.5	7.5		
		6			5.5	7.5	7.5	7.5	7.5	7.5	7.5		
21W4	21000	4			7.5	7.5	7.5	11.0	11.0	11.0			
		6			7.5	7.5	11.0	11.0	11.0	11.0			
24W4	24000	4				7.5	11.0	11.0	11.0	11.0			
		6				11.0	11.0	11.0	11.0	11.0			
27W4	27000	4					11.0	11.0	11.0	11.0			
		6					11.0	11.0	11.0	11.0	15.0		
30W4	30000	4						11.0	11.0	15.0	15.0		
		6						11.0	15.0	15.0	15.0		
33W4	33000	4							11.0	15.0	15.0	15.0	15.0
		6							15.0	15.0	15.0	15.0	18.5
35W4	35000	4							11.0	15.0	15.0	15.0	15.0
		6							15.0	15.0	15.0	15.0	18.5
40W4	40000	4								15.0	15.0	18.5	18.5
		6								15.0	15.0	18.5	18.5
45W4	45000	4								18.5	18.5	18.5	22.0
		6								18.5	18.5	18.5	22.0
50W4	50000	4									22.0	22.0	
		6									22.0	22.0	



## Specification of Humidifier

### Specification of Wet-film Humidifier

Model HZK	Air Flow (m³/h)	Weight(kg)		Humidification Amount of Fresh Air(kg/h)		Humidification Amount of Mixed Air(kg/h)	
		50mm Thickness	100mm Thickness	50mm Thickness	100mm Thickness	50mm Thickness	100mm Thickness
02	2000	2	4	5	11	4	9
03	3000	3	5	7	15	6	12
04	4000	3	7	10	19	8	16
05	5000	4	8	12	23	9	19
06	6000	5	10	14	29	11	24
07	7000	6	12	16	33	13	27
08	8000	7	14	19	38	15	31
09	9000	8	16	22	43	17	36
10	10500	9	18	25	51	20	42
12	12000	10	20	28	57	23	47
13	13500	12	24	33	66	26	54
15	15000	13	25	35	70	28	58
18	18000	15	30	42	83	33	69
21	21000	18	35	49	97	39	80
24	24000	20	40	55	111	44	92
27	27000	22	44	62	123	49	102
30	30000	24	49	68	136	54	112
33	33000	27	54	75	150	60	124
35	35000	28	57	79	158	63	130
40	40000	31	62	86	172	69	142
45	45000	35	69	96	193	77	159
50	50000	39	77	107	214	86	177

### Wet-film Humidifier

The wet-film humidifier is made of hydrophilic materials, which can evenly distribute the water absorbed on the surface of the material to form a vaporized layer of water. When the air flows through the surface of the material, the water in the vaporized layer is evaporated and absorbed by the air flow. The thickness of the wet film can be 50mm or 100mm according to the amount of humidification, and the water supply is 3 times of the amount of humidification.

### Using Conditions

Ambient Temp and Humidity:	5- 80°C; ≤90%RH	Water State:	0.05- 0.4MPa,5- 40°C
Critical Air Flow:	< 3.75m/s	Water Supply Quantity:	2-3 Times of Humidification Amount
Water Quality:	Tap-water, Purified Water	Power Supply:	AC220V/50HZ

- Note:
- Working condition of fresh air: 28°C DB, 10%RH; Face Velocity ≤ 3.0m/s
  - Working condition of mixed air (fresh air accounted for 30%): 28°C DB, 25%RH; Face Velocity ≤ 3.0m/s
  - The weight of the wet-film in the above table is the dry weight when there is no water absorbed. The wet weight (weight under working state) is about 1.5 times of the dry weight.
  - The humidification amount in the above table is the maximum humidification amount corresponding to different models of wet-film humidifiers.
  - When the AHU is equipped with the wet-film humidifier, the internal resistance of the unit should be increased accordingly: 50mm-20pa; 100mm-30pa.

## Control System

### Functions

The onboard control system of HKG is adopted to control the fan and the water valve of 220V. The control system is mainly composed of low-voltage electrical components and temperature controllers of well-known brands. When the temperature controller with the communication function is configured, it can be easily connected with the third-party control system such as BMS to achieve remote and networked monitoring. Besides, the control cabinet is equipped with multiple protections of short circuit, power loss and overload, etc. to ensure the reliable operation. If there is a switch-type water valve connected, the water valve can be switched off when the indoor temperature reaches the setting value, achieving energy saving.



### Features

#### Control Cabinet

- Professional design, integrated control, reasonable wiring and various protections;
- Standardized design for convenient installation;
- Various external interlocks, reserved control signals for fire valve, fresh air valve (stop or start together with the fan motor) and water valve;
- Control cabinet can be installed before shipment, simplifying the installation progress on site.

#### Temperature Controller

- Grand and elegant appearance, large size LCD, one-button booting;
- Multiple states display;
- Built-in temperature sensor to display the indoor temperature;
- Equipped with high reliability microcontroller.

Note: The control cabinet and the temperature controller are optional.

### Installation Instructions of Control Cabinet

When the motor power is less than or equal to 7.5kW, the control cabinet has been installed on the side or upper of the AHU and the wiring of motor has already been finished before delivery. The temperature controller need to be installed in the operation room. The signal line between the temperature controller and the control cabinet and the power wire of control cabinet should be connected on site.

When the motor power is more than or equal to 11kW, it adopts star-delta starting mode. The control cabinet is delivered as an independent accessory and the temperature controller has been installed on its panel. The power wire of control cabinet, the power wire between control cabinet and motor should be connected on site.

### Others

It's energy saving to install the water valve. But it's forbidden to install water valve when total fresh air condition.



Electrical Wiring Diagram And Foundation Drawing

Electrical Wiring Diagram

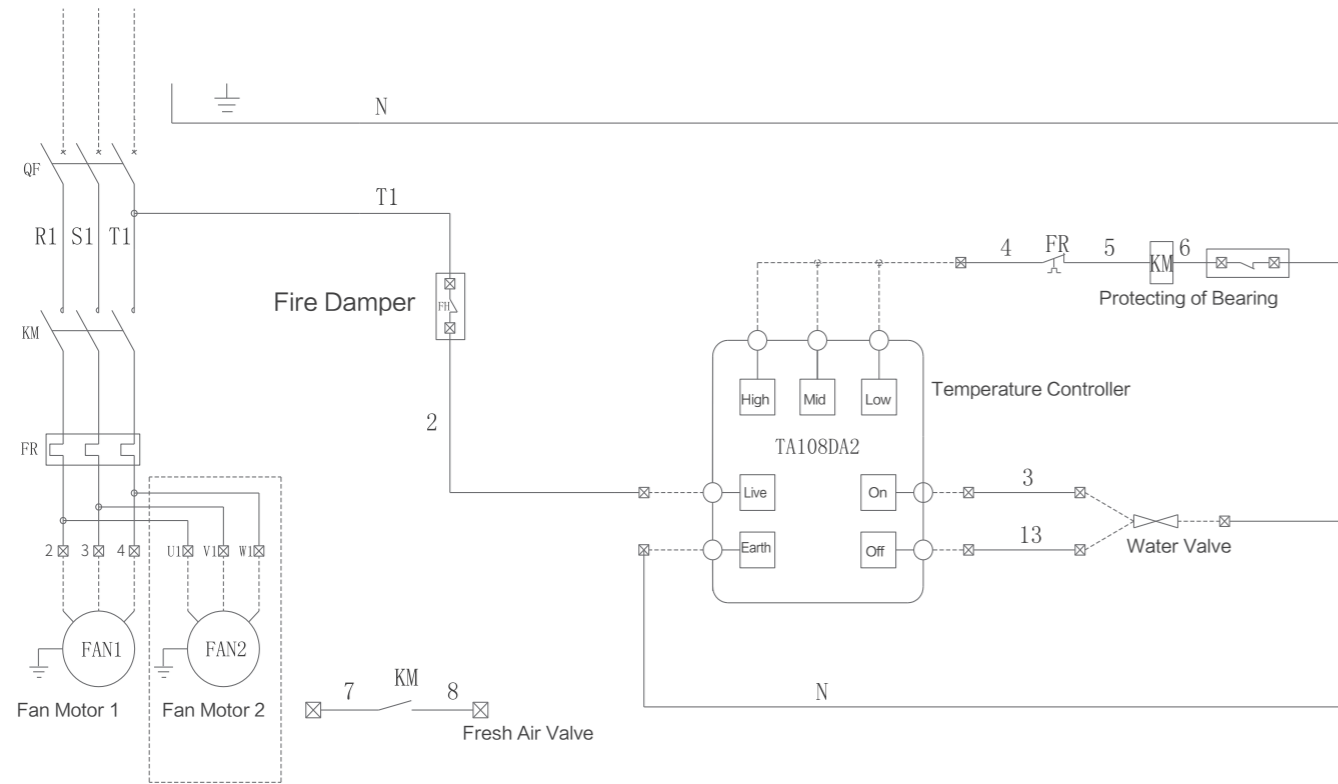

Foundation Drawing

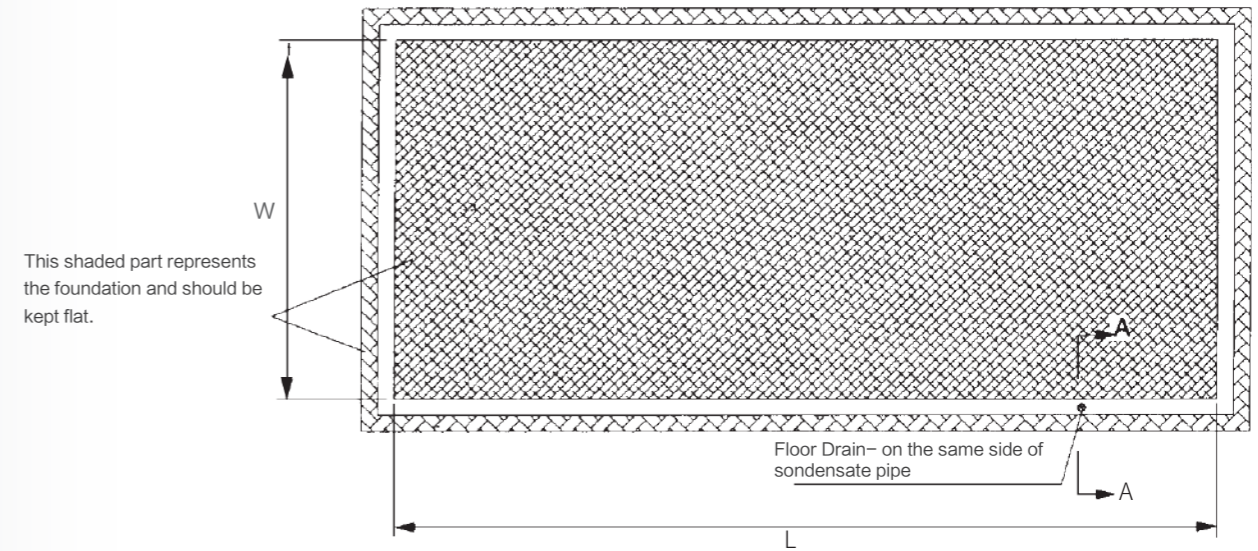

$L = \text{Unit Length} + 200$   
 $W = \text{Unit Width} + 200$   
 $H = \text{Foundation Height}$

$H \geq 150$ ; Need to satisfy the height demand of drain pipe installation.

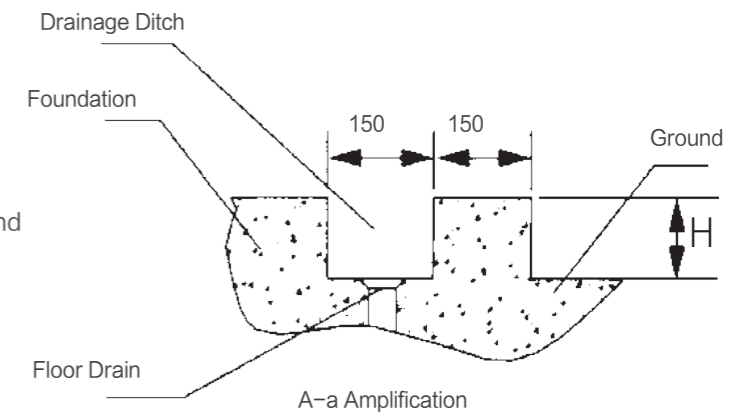

# CEILING SUSPENDED AHU

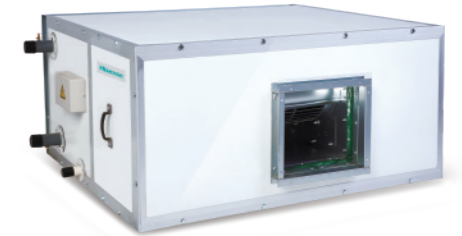
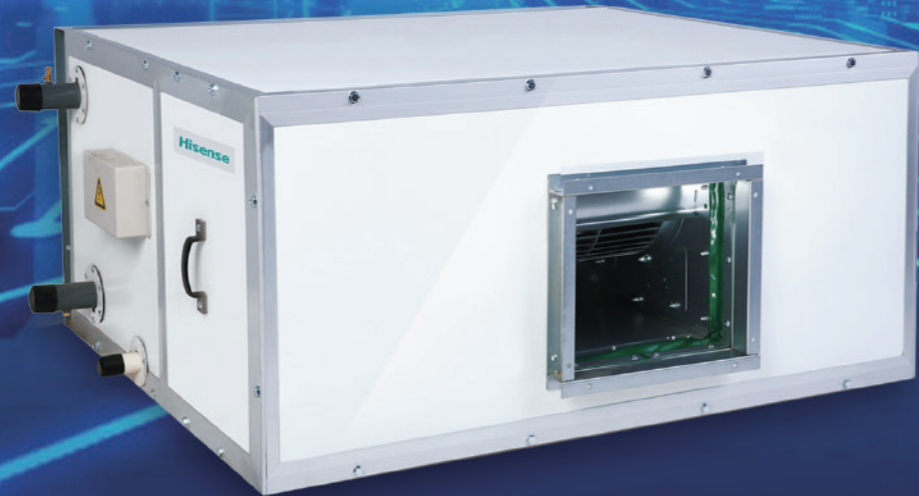

2000~15000m³/h

## Features

Ceiling suspended air handling unit is mainly composed of filter, coil and fan, etc. and can meet various static pressure needs. Because of its compact structure, light weight, excellent cooling performance, and the optional components of electric heater, wet-film humidifier or electrical controller, the ceiling type air handling unit can be widely used in the places with centralized air handing demands such as shopping malls, hotels, office buildings and so on. The units with air flow of less than 2500m³/h is direct-driven type and units with air flow of more than 3000m³/h is belt-driven type.

\*If the unit is planned to be installed near the coast or in the chemical-corrosion environment, please firstly consult with our local engineer.

### Diagram to Distinguish the Left and Right Type of the Unit

Facing the air flow, if water piping at left side indicates left type. Otherwise, right type.

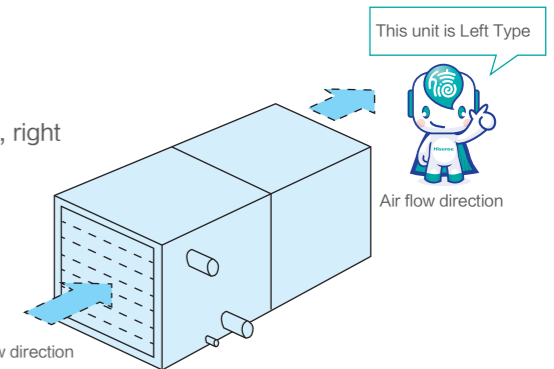

### Nomenclature

HKGE - 02	D	A	/	S	D	C	300	H	Z	BN	#	d	D	
														Feature Type: D-direct driven(380V), B-belt driven(380V), S-jet(380V)
														Auxiliary Electrical Heater: d-equipped, default-none
														Heat Exchanger: BN-3 rows, GN-5 rows
														Piping Direction: Z-left, Y-right
														Handling Conditions: H-return air, X-fresh air
														External Static Pressure: Pa
														Design Code: C
														Motor Model: D-DC, default-AC
														Power Supply: S-3Φ, default-1Φ
														Installation: A-concealed, M-unconcealed
														Structure Type: D-Ceiling
														Air Volume Code: specifications × 1000m³/h
														Name Code: Ceiling Suspended AHU

88

Features

90

Specification

94

Control System

95

Wiring Diagram

### Labyrinth Seal Structure Design, Low Air Leakage Rate

It is designed with labyrinth seal structure. The aluminum profile with concave and convex grooves is adopted at the junction of housing and further fastened by bolts and nuts, forming a labyrinth sealing structure. The air leakage rate is extremely low, only 1/66 of the allowable air leakage as specified in the national standards.

### Firm Structure Design

The air handling unit is composed with an outer aluminum alloy frame and a concealed inner metal frame. The outer aluminum alloy frame is fastened by the tenon structure, bolts and nuts to form a torsion-resistant rigid body, while the inner concealed metal frame greatly increases the strength of the unit.



### Prevention Of Cold Bridge and Rust

All metals inside the labyrinth body are isolated from the outside by means of polyurethane foam and specially designed seals, avoiding the sticking of insulation strips everywhere inside the housing as the common AHU and it simply eliminates the cold bridge problem (cold bridge factor of unit is up to 0.88, TB1 grade by reference to European Standard EN1886-2007). All panels are inlaid with aluminum profile frame on all edges so that the corners and edges of sheet metal are totally isolated from air and moisture, thereby preventing rust spots on panels.

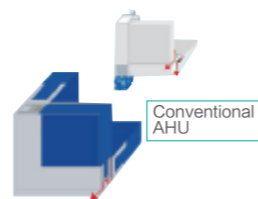

### Integrated Seamless Water Tray with No Water Leakage

The AHU adopts the integrated water tray which is possessed by the advanced German-made spraying equipment and then pasted with the integral insulation material. It is installed on the bottom of the AHU on the full size, so that there will be no water leakage worry during operation.

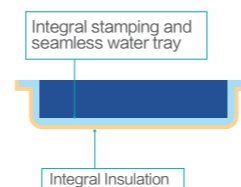

### Mechatronics Control

Adopt the large LCD controller, which can realize one-button booting and automatic operation, various working conditions display. High reliability microcontroller is configured with high anti-interference. The main components are supplied by international famous brands for reliable and guaranteed quality. Various external interlocks are adopted. Control signals for fire valve, fresh air valve and water valve are reserved.



## Specification

### Return Air Condition

Model	Air Flow m³/h	Three Rows					Five Rows					Drain Pipe Diameter DN	Power Supply	Driven Type
		Rated Cooling Capacity kW	Rated Heating Capacity kW	Water Flow l/s	Water Resistance kPa	Chilled Water Pipe Diameter DN	Rated Cooling Capacity kW	Rated Heating Capacity kW	Water Flow l/s	Water Resistance kPa	Chilled Water Pipe Diameter DN			
HKGE-02DA	2000	11.5	21.2	0.55	59.2	32	14.9	25.3	0.71	84.9	32	25	AC 3Φ, 380V/ 50Hz	Belt driven
HKGE-03DA	3000	17.5	32.0	0.83	63.8	32	22.0	37.3	1.05	76.2	32	25		
HKGE-04DA	4000	23.4	41.5	1.13	89.7	32	30.1	49.1	1.43	87.1	32	25		
HKGE-05DA	5000	28.3	51.4	1.37	76.2	32	35.2	61.8	1.68	47.3	40	25		
HKGE-06DA	6000	34.5	61.7	1.64	86.4	32	43.7	73.9	2.08	76.0	40	25		
HKGE-07DA	7000	40.3	71.3	1.92	81.0	32	49.4	85.3	2.35	70.6	40	25		
HKGE-08DA	8000	46.2	83.1	2.20	81.2	32	57.6	98.3	2.74	89.9	40	25		
HKGE-10DA	10000	59.9	108.1	2.85	88.9	40	75.1	135.3	3.58	55.8	50	25		
HKGE-12DA	12000	69.3	131.7	3.30	89.8	40	85.8	161.1	4.09	76.9	50	25		
HKGE-15DA	15000	85.3	162.8	4.06	89.8	50	108.5	189.7	5.17	77.5	50	32		

Note:

- Standard cooling conditions: chilled water inlet/outlet at 7/12°C; air inlet at 27°CDB/19.5°CWB.
- Standard heating conditions: hot water inlet/outlet at 60/50°C; air inlet at 15°CDB.
- Specifications are subject to change without prior notice.
- The water flow in the above table is the chilled water flow rate, and the heated water flow rate is smaller than the chilled water flow rate. So the model selection of the pump shall refer to the chilled water flow.



Fresh Air Condition

Model	Air Flow	Three Rows					Five Rows					Drain Pipe Diameter	Power Supply	Driven Type
		Rated Cooling Capacity	Rated Heating Capacity	Water Flow	Water Resistance	Chilled Water Pipe Diameter	Rated Cooling Capacity	Rated Heating Capacity	Water Flow	Water Resistance	Chilled Water Pipe Diameter			
		m³/h	kW	kW	l/s	kPa	DN	kW	kW	l/s	kPa			
HKGE-02DA	2000	27.0	27.5	1.29	84.8	32	31.2	31.3	1.49	64.6	32	25	AC 3Φ, 380V/ 50Hz	Belt driven
HKGE-03DA	3000	39.9	40.9	1.90	87.0	32	45.8	45.1	2.18	80.5	32	25		
HKGE-04DA	4000	49.7	51.1	2.37	79.9	32	63.8	61.8	3.04	66.3	40	25		
HKGE-05DA	5000	64.5	64.0	3.07	84.0	32	75.4	70.3	3.59	81.6	40	25		
HKGE-06DA	6000	72.7	75.5	3.46	38.5	50	92.6	91.9	4.41	80.5	40	25		
HKGE-07DA	7000	84.1	87.1	4.00	61.0	50	105.6	104.8	5.03	79.5	50	25		
HKGE-08DA	8000	99.0	101.7	4.71	87.7	50	120.7	119.7	5.75	85.7	50	25		
HKGE-10DA	10000	133.1	133.3	6.34	50.6	65	160.2	157.9	7.63	60.2	65	25		
HKGE-12DA	12000	149.4	155.1	7.12	69.1	65	185.2	180.4	8.20	82.1	65	25		
HKGE-15DA	15000	184.2	200.2	8.77	69.1	65	244.7	237.1	10.65	82.1	65	32		

Note:

- Standard cooling conditions: chilled water inlet/outlet at 7/12°C; air inlet at 35°CDB/28°CWB.
- Standard heating conditions: hot water inlet/outlet at 60/50°C; air inlet at 7°CDB.
- Specifications are subject to change without prior notice.
- The water flow in the above table is the chilled water flow rate, and the heated water flow rate is smaller than the chilled water flow rate. So the model selection of the pump shall refer to the chilled water flow.

Power Input Under Different ESP

Model	Air flow (m³/h)	Rows of Heat Exchanger	Power Input (kW) Under Certain ESP (Pa)							
			120	160	200	240	280	320	360	400
HKGE-02DA	2000	3	0.32	0.32	0.37	0.37	0.45	0.45		
		5	0.32	0.37	0.37	0.45	0.45	0.55		
HKGE-03DA	3000	3		0.55	0.75	0.75	0.75	0.75	1.1	1.1
		5		0.75	0.75	0.75	0.75	1.1	1.1	1.1
HKGE-04DA	4000	3		1.1	1.1	1.1	1.1	1.1	1.1	1.5
		5		1.1	1.1	1.1	1.1	1.1	1.5	1.5
HKGE-05DA	5000	3		1.1	1.1	1.1	1.1	1.5	1.5	1.5
		5		1.1	1.1	1.1	1.5	1.5	1.5	1.5
HKGE-06DA	6000	3		1.1	1.1	1.5	1.5	1.5	1.5	2.2
		5		1.1	1.5	1.5	1.5	1.5	2.2	2.2
HKGE-07DA	7000	3		1.5	1.5	2.2	2.2	2.2	2.2	2.2
		5		1.5	2.2	2.2	2.2	2.2	2.2	2.2
HKGE-08DA	8000	3		2.2	2.2	2.2	2.2	2.2	3.0	3.0
		5		2.2	2.2	2.2	2.2	3.0	3.0	3.0
HKGE-10DA	10000	3		2.2	3.0	3.0	3.0	3.0	3.0	3.0
		5		3.0	3.0	3.0	3.0	3.0	3.0	4.0
HKGE-12DA	12000	3			3.0	3.0	3.0	4.0	4.0	4.0
		5			3.0	3.0	4.0	4.0	4.0	4.0
HKGE-15DA	15000	3					4.0	4.0	5.5	5.5
		5					4.0	5.5	5.5	5.5



## External Dimension Of Standard Type

### Direct-drive Type & Belt-driven Type series

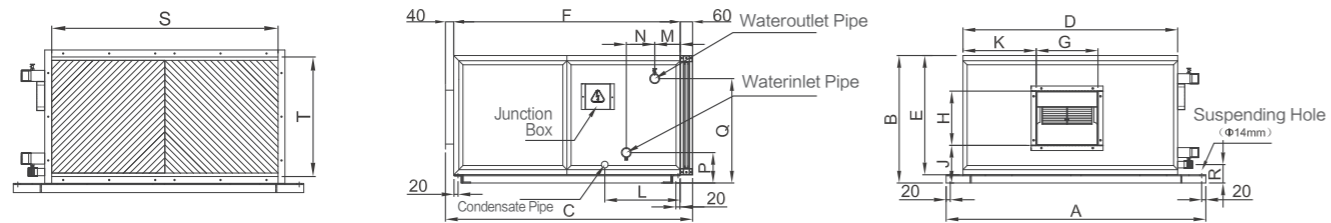

Model	A (mm)	B (mm)	C (mm)	D (mm)	E (mm)	F (mm)	Flange of Air Outlet L × W (mm)		J (mm)	K (mm)	L (mm)	M		N		P (mm)	Q (mm)	R (mm)	Flange of Return Air (L × W) (mm)		Weight (kg)	
							G	H				3 rows	5 rows	3 rows	5 rows				S	T	3 rows	5 rows
HKGE-02DA	1007	545	900	843	505	800	302	275	122	277	385	108	86	64	108	150	413	90	783	445	71	81
HKGE-03DA	1167	625	950	1003	585	850	302	262	184	226	385	108	86	64	108	150	514	90	943	525	90	121
HKGE-04DA	1387	625	950	1223	585	850	331	289	146	356	385	108	86	64	108	150	514	90	1163	525	99	129
HKGE-05DA	1567	635	950	1403	585	850	331	289	156	446	385	108	86	64	108	150	514	90	1343	525	128	158

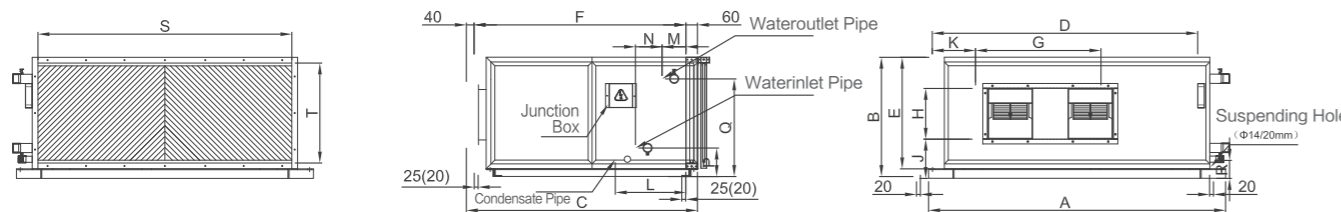

Model	A (mm)	B (mm)	C (mm)	D (mm)	E (mm)	F (mm)	Flange of Air Outlet L × W (mm)		J (mm)	K (mm)	L (mm)	M		N		P (mm)	Q (mm)	R (mm)	Flange of Return Air (L × W) (mm)		Weight (kg)		
							G	H				3 rows	5 rows	3 rows return air/fresh air	5 rows				S	T	3 rows	5 rows	
HKGE-06DA	1757	635	950	1593	585	850	840	262	214.5	226	385	108	86	64	94	108	150	514	90	1533	525	139	180
HKGE-07DA	1997	635	950	1833	585	850	840	262	214.5	346	385	108	86	64	94	108	150	514	90	1773	525	192	222
HKGE-08DA	2207	635	950	2043	585	850	840	262	214.5	451	385	108	86	64	94	108	150	514	90	1983	525	231	271
HKGE-10DA	2287	790	1050	2123	740	950	862	341	214.5	483	385	108	86	64	108	155	667	90	2063	680	279	309	
HKGE-12DA	2477	790	1050	2313	740	950	1114	341	214.5	437	385	108	86	64	108	155	667	90	2253	680	287	311	
HKGE-15DA	2477	940	1150	2313	890	1050	1040	404	214.5	557	385	108	86	94	108	155	819	90	2253	830	372	414	

- Note:
- The above size of the units does not include the size of heating coil. If heating coil needs to be added, the value of F needs to be increased by 100mm.
  - The size and weight of control cabinet are not included in the above table.
  - 25(20) is the distance between the lifting hole and the outer edge of the bottom frame. 20 is for the unit HKGE-02\*~HKGE-04\*, and 25 is for the other.
  - The suspending hole diameter for HKGE-15\* is  $\Phi 20\text{mm}$ , others  $\Phi 14\text{mm}$ .

## Control System

### Functions

The onboard control system of HKGE is adopted to control the fan and the water valve of 220V. The control system is mainly composed of low-voltage electrical components and temperature controllers of well-known brands. When the temperature controller with the communication function is configured, it can be easily connected with the third-party control system such as BMS to achieve remote and networked monitoring. Besides, the control cabinet is equipped with multiple protections of short circuit, power loss and overload, etc. to ensure the reliable operation. If there is a switch-type water valve connected, the water valve can be switched off when the indoor temperature reaches the setting value, achieving energy saving.

### Features

#### Control Cabinet

- Professional design, integrated control, reasonable wiring and various protections;
- Standardized design for convenient installation;
- Various external interlocks, reserved control signals for fire valve, fresh air valve (stop or start together with the fan motor) and water valve;
- Control cabinet can be installed before shipment, simplifying the installation progress on site.

#### Temperature Controller

- Grand and elegant appearance, large size LCD, one-button booting;
- Multiple states display;
- Built-in temperature sensor to display the indoor temperature;
- Equipped with high reliability microcontroller;

Note:  
The control cabinet and teperature controller are both optional accessories.



## Wiring Diagram

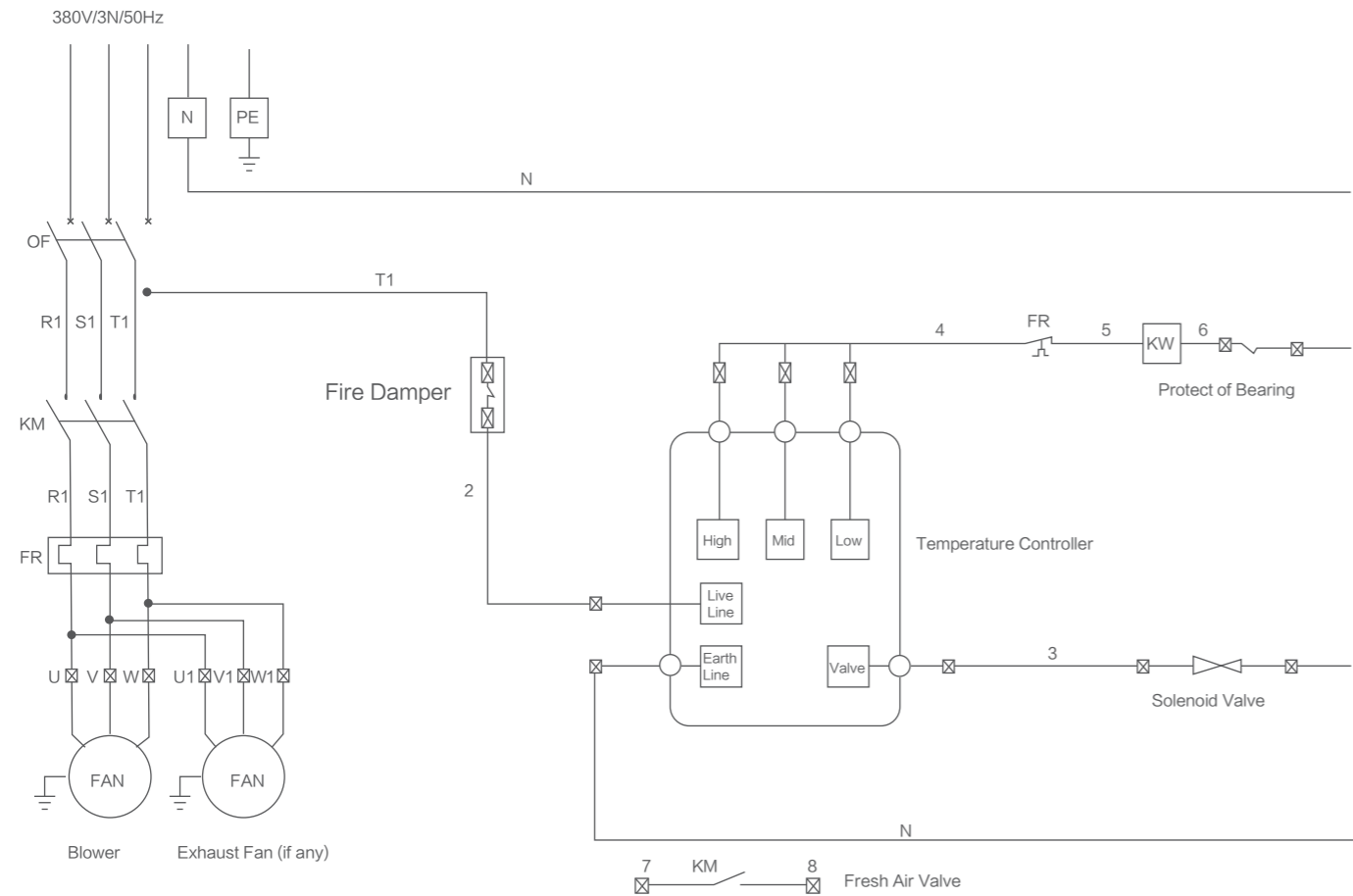

## FAN COIL UNIT



97

Nomenclature

98

Ceiling Concealed  
Fan Coil Unit

103

Ceiling & Floor Unconcealed  
Fan Coil Unit

107

DC Cassette Fan Coil Unit

112

AC Cassette Fan Coil Unit



## Nomenclature

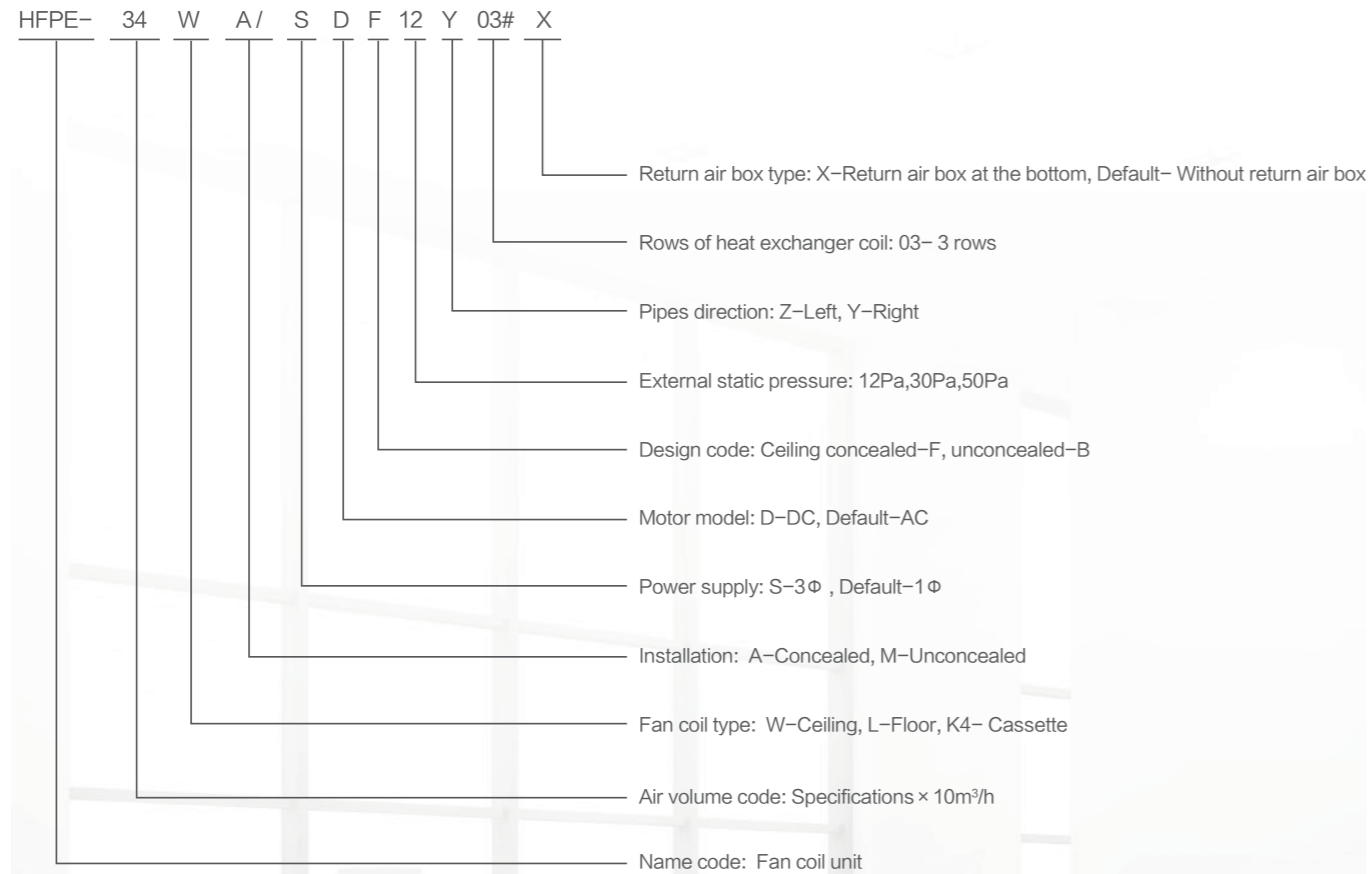

## CEILING CONCEALED FAN COIL UNIT



### Compact Body

The unit is designed with compact body and excellent appearance. The height of the unit is as thin as 230mm, which can fit into the narrowest ceiling spaces, saving ceiling spaces for higher room height without compromising users' comfort and satisfaction; Besides, ceiling concealed design can match with various interior decorations.

### Multiple Static Pressure Choices

Users can freely choose the products with static pressure of 12Pa, 30Pa and 50Pa according to their needs, to meet the requirements of air supply distance in different occasions.

### 3 Fan Speed

Three fan speeds are available to satisfy the various needs of different indoor conditions.

### Super-low Noise Operation

Low noise and low speed centrifugal fans with large impellers are equipped in the fan coil unit, and it cooperates with the motor perfectly after strict static-dynamic balance test, ensuring less vibration and lower noise.

### High-level Protection Enclosed Fan Motor

The fan motor with new design is high efficiency and consumes less electricity. Besides, the motor protection class is IP44, which reduces the risk of use and ensures the long-term reliable operation.

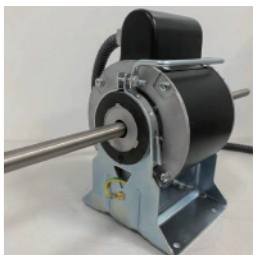

### High-quality Condensate Water Pan

The condensate water pan is made from one-piece stretched metal without solder joints or welds. Also the design of double-sided plastic spray ensures reliable corrosion resistance.



What's more, the water pan has a certain slope, which facilitates the drainage of condensed water and reduces the risk of bacteria growing. The thermal insulation layer is bonded under pressure integrately, which is firm without warping.



## Specification

Model(HFPE--**WA/F)				34	51	68	85	102	119	136	170	204	238	
Airflow rate (ESP 12Pa,30Pa,50Pa)	H	CFM		200	300	400	500	600	700	800	1000	1200	1400	
		m³/h		340	510	680	850	1020	1190	1360	1700	2040	2380	
	M	m³/h		255	383	510	638	765	893	1020	1275	1530	1785	
		m³/h		170	255	340	425	510	595	680	850	1020	1190	
Cooling capacity	Total	H	W	2250	3350	4300	5100	5770	6650	8250	9350	11200	13100	
	Sensible	H	W	1598	2379	3053	3621	4097	4722	5858	6639	7952	9301	
Heating capacity(45°C water inflow)	H	W		2250	3350	4300	5100	5770	6650	8250	9350	11200	13100	
Heating capacity(60°C water inflow)	H	W		3550	5400	6850	8450	9530	11200	13600	15850	18400	21550	
Power input	12Pa	H	W	31	43	56	73	93	110	128	146	182	220	
		M	W	26	37	46	64	73	95	110	120	154	192	
		L	W	24	28	37	47	60	74	86	108	120	164	
	30Pa	H	W	38	53	69	83	104	119	142	168	204	244	
		M	W	32	45	58	73	93	105	120	154	190	223	
		L	W	27	36	46	62	75	95	104	141	160	195	
	50Pa	H	W	45	62	80	95	112	130	166	200	237	289	
		M	W	39	52	65	86	107	124	146	191	222	266	
		L	W	35	46	56	70	91	105	119	171	198	246	
	Sound pressure	12Pa	H	dB(A)	35.0	36.5	40.5	43.0	45.0	46.0	45.0	48.0	49.0	51.0
			M	dB(A)	28.5	31.0	33.0	36.3	39.5	40.3	40.0	42.0	44.3	44.0
			L	dB(A)	22.0	23.0	24.0	26.0	30.0	34.0	30.0	36.0	33.4	34.5
30Pa		H	dB(A)	38.0	39.0	42.0	42.0	46.0	45.0	45.0	49.5	48.0	50.0	
		M	dB(A)	30.0	31.0	35.0	37.0	39.0	41.0	41.0	44.9	44.0	45.0	
		L	dB(A)	24.5	25.5	26.0	27.3	28.0	34.0	32.0	37.0	34.7	41.0	
50Pa		H	dB(A)	40.0	43.0	44.5	46.0	48.0	47.0	49.0	49.5	50.0	51.0	
		M	dB(A)	32.0	38.0	38.0	40.0	42.0	43.0	43.5	46.0	47.0	47.0	
		L	dB(A)	25.5	30.0	31.5	31.0	35.0	37.3	33.0	42.0	44.0	44.5	
Water flow rate		m³/h	0.39	0.58	0.74	0.88	0.99	1.14	1.42	1.61	1.93	2.25		
Water pressure drop	Cooling	kPa		22	27	25	30	25	34	27	38	35	41	
	Heating			16	24	20	22	21	30	21	30	31	31	
Coil	Type	Louver aluminum fin mechanically inserted by red copper pipes												
	Operating pressure	1.6MPa												
Fan	Type	Front curved multi-wing galvanized steel plate centrifugal fan with double-suction impeller												
	Quantity		1	2	2	2	2	2	2	3	4	4	4	

Model(HFPE--**WA/F)			34	51	68	85	102	119	136	170	204	238	
Motor	Type	High precision low noise ball bearing single-phase capacitor motor											
	Quantity		1	1	1	1	1	1	1	2	2	2	2
	Power supply	220V/1P/50Hz											
	Protection level	IP44											
	Insulation level	B/F											
Water inlet/outlet connection pipe			Rc 3/4 Taper pipe internal thread										
Condensate connection pipe			R 3/4 Taper pipe external thread										
Without return air box		kg	11	14.5	15	16.5	18	19.5	26	28	31	32.5	
With return air box		kg	13.8	17.8	18.8	20	22	24	31.5	33.5	37	39	
Dimensions (Without return air box)	W	mm	677	817	892	972	1062	1217	1447	1497	1697	1847	
	D	mm	469										
	H	mm	230										
Dimensions (With return air box)	W	mm	677	817	892	972	1062	1217	1447	1497	1697	1847	
	D	mm	505										
	H	mm	249										

Notes:

1.The nominal cooling capacity and heating capacity are based on the following conditions:

Cooling operation conditions: indoor air inlet temperature: 27°C DB 19.5°C WB, Inlet water temperature: 7°C, Outlet water temperature:12°C.

Heating operation conditions: indoor air inlet temperature: 21°C DB, Inlet water temperature: 60°C/45°C,The water flow is the same as the cooling condition.

2. Rated air volume is tested based on following conditions: standard air condition, dry coil condition(20°C DB).

3. The sound pressure level is tested in a semi-anechoic room using the unit without return air box and filter.The actual sound value may be different from the data in the above table due to the influence of environmental noise and other reasons. The sound pressure level of the unit that adopts the bottom return air will be higher than that of the rear return air.

4. H, M and L in the table represent high, medium and low fan speeds.

5. The ESP in the table is the value of ESP of air outlet.

6.The performance parameters in the table were measured under the power supply 220V/50Hz.

7.The indoor unit can change the left / right connection on site. After changing the direction of the connecting pipe, the cooling capacity / heating capacity of the indoor unit needs to be corrected with the factor 0.86-0.92.

8.The air volume, cooling capacity and heating capacity in the above table are all measured under the condition of without return air box and filter; For the indoor unit with return air box at the bottom, the data should be corrected with the factor 0.93-0.96 correspondingly.

## Correction Coefficient of Cooling Capacity under Variable Working Conditions

Indoor air inlet temperature: 27°C DB/ 19.5°C WB																	
Model	Water flow (m³/h)	Inlet water temperature															
		5		6		7		8		9		10		11		12	
		Total heat	Sensible heat	Total heat	Sensible heat	Total heat	Sensible heat	Total heat	Sensible heat	Total heat	Sensible heat	Total heat	Sensible heat	Total heat	Sensible heat	Total heat	Sensible heat
HFPE-34WA	0.39	1.14	1.14	1.05	1.05	1.00	1.00	0.93	0.93	0.85	0.85	0.78	0.78	0.71	0.71	0.65	0.65
HFPE-51WA	0.58	1.14	1.14	1.05	1.05	1.00	1.00	0.93	0.93	0.85	0.85	0.78	0.78	0.71	0.71	0.65	0.65
HFPE-68WA	0.74	1.14	1.14	1.05	1.05	1.00	1.00	0.93	0.93	0.85	0.85	0.78	0.78	0.71	0.71	0.65	0.65
HFPE-85WA	0.88	1.14	1.14	1.05	1.05	1.00	1.00	0.93	0.93	0.85	0.85	0.78	0.78	0.71	0.71	0.65	0.65
HFPE-102WA	0.99	1.14	1.14	1.05	1.05	1.00	1.00	0.93	0.93	0.85	0.85	0.78	0.78	0.71	0.71	0.65	0.65
HFPE-119WA	1.14	1.14	1.14	1.05	1.05	1.00	1.00	0.93	0.93	0.85	0.85	0.78	0.78	0.71	0.71	0.65	0.65
HFPE-136WA	1.42	1.14	1.14	1.05	1.05	1.00	1.00	0.93	0.93	0.85	0.85	0.78	0.78	0.71	0.71	0.65	0.65
HFPE-170WA	1.61	1.14	1.14	1.05	1.05	1.00	1.00	0.93	0.93	0.85	0.85	0.78	0.78	0.71	0.71	0.65	0.65
HFPE-204WA	1.93	1.14	1.14	1.05	1.05	1.00	1.00	0.93	0.93	0.85	0.85	0.78	0.78	0.71	0.71	0.65	0.65
HFPE-238WA	2.25	1.14	1.14	1.05	1.05	1.00	1.00	0.93	0.93	0.85	0.85	0.78	0.78	0.71	0.71	0.65	0.65



WB/°C	DB/°C	23°C		24°C		25°C		26°C		27°C		28°C	
		Total heat	Sensible heat	Total heat	Sensible heat	Total heat	Sensible heat	Total heat	Sensible heat	Total heat	Sensible heat	Total heat	Sensible heat
16.5		0.72	0.83										
17.0				0.79	0.89								
18.0						0.87	0.94	0.87	0.99				
19.0								0.95	0.97	0.99	1.04		
19.5										1	1		
20.0										1.03	0.98	1.04	1.06
21.0												1.12	1.01

Correction Coefficient Of Heating Capacity under Variable Working Conditions

Indoor air inlet temperature: 21°C DB							
Model	Water flow(m³/h)	Inlet water temperature					
		35	40	45	50	55	60
HFPE-34WA	0.39	0.34	0.47	0.64	0.77	0.88	1.00
HFPE-51WA	0.58	0.34	0.47	0.63	0.77	0.88	1.00
HFPE-68WA	0.74	0.34	0.47	0.63	0.77	0.88	1.00
HFPE-85WA	0.88	0.34	0.47	0.61	0.77	0.88	1.00
HFPE-102WA	0.99	0.34	0.47	0.62	0.77	0.88	1.00
HFPE-119WA	1.14	0.34	0.47	0.62	0.77	0.88	1.00
HFPE-136WA	1.42	0.34	0.47	0.61	0.77	0.88	1.00
HFPE-170WA	1.61	0.34	0.47	0.61	0.77	0.88	1.00
HFPE-204WA	1.93	0.34	0.47	0.61	0.77	0.88	1.00
HFPE-238WA	2.25	0.34	0.47	0.61	0.77	0.88	1.00

DB/°C	19°C	20°C	21°C	22°C	23°C	24°C
Heating	1.06	1.03	1.00	0.98	0.94	0.92

Dimensions

Ceiling Concealed Fan Coil Unit

Without Return Air Box

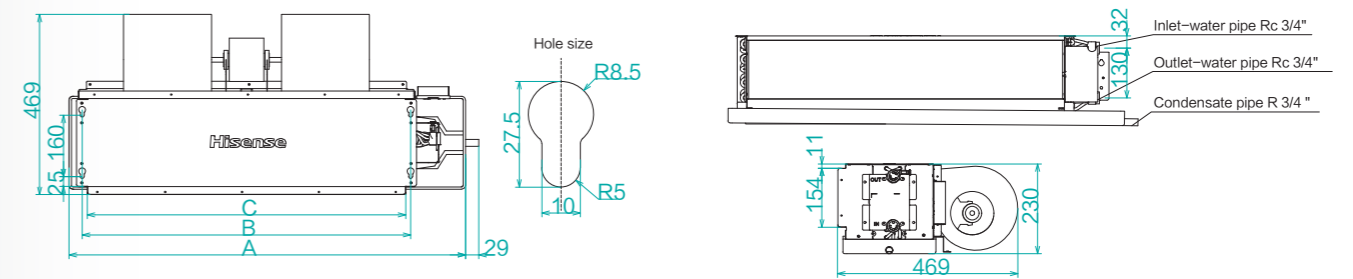

Model	HFPE-34	HFPE-51	HFPE-68	HFPE-85	HFPE-102	HFPE-119	HFPE-136	HFPE-170	HFPE-204	HFPE-238
A	647	787	862	942	1032	1187	1417	1467	1667	1817
B	470	610	685	765	855	1010	1240	1290	1490	1640
C	444	584	659	739	829	984	1214	1264	1464	1614

With Return Air Box

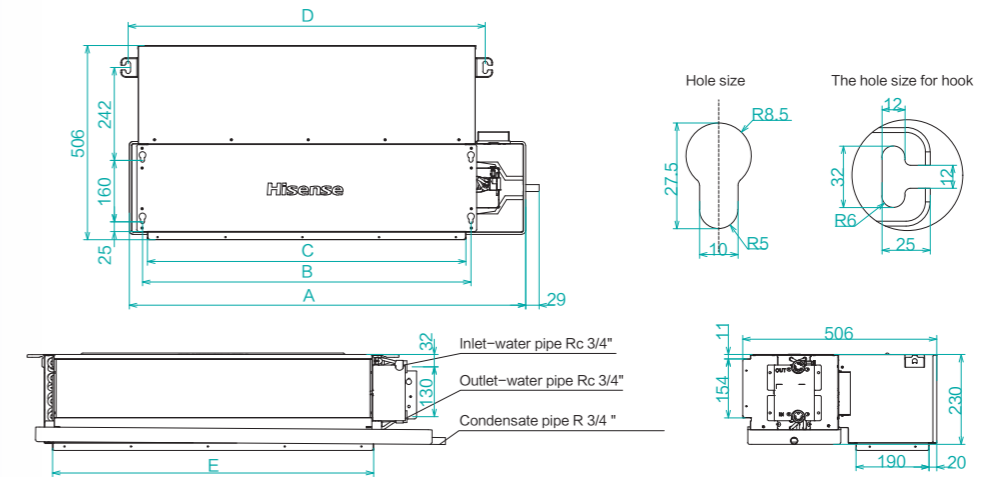

Model	HFPE-34	HFPE-51	HFPE-68	HFPE-85	HFPE-102	HFPE-119	HFPE-136	HFPE-170	HFPE-204	HFPE-238
A	647	787	862	942	1032	1187	1417	1467	1667	1817
B	470	610	685	765	855	1010	1240	1290	1490	1640
C	444	584	659	739	829	984	1214	1264	1464	1614
D	545	685	761	841	931	1085	1315	1365	1565	1715
E	451	591	666	746	836	991	1221	1271	1471	1621



# CEILING & FLOOR UNCONCEALED FAN COIL UNIT



## Flexible Installation and Space-saving

Thanks to the compact body design, the units can be installed flexibly, especially in narrow spaces. Also it can save the indoors space greatly.

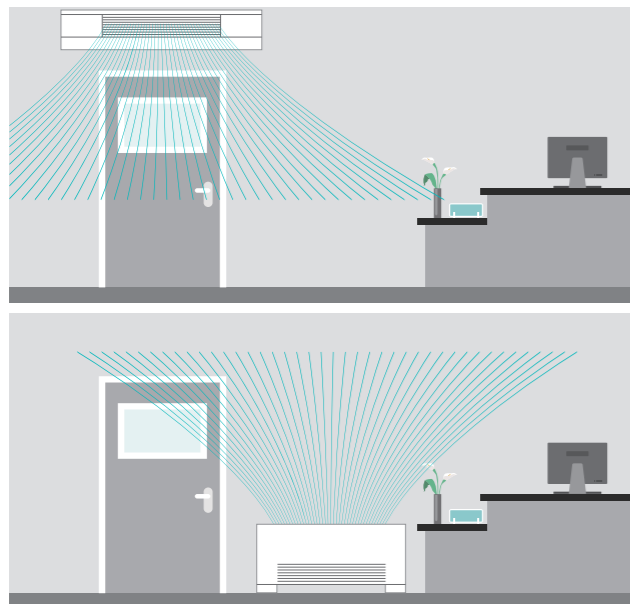

## Stable Quality with Advanced Process

All the units are made of fireproof materials, and the motor shaft specially uses the anti-corrosion materials. The motor is made of low-noise rolling bearings with service life of 100,000 hours.

## Low-noise Operation

Adopt the low-noise centrifugal fan with professional fan impeller design. Also, the motor adopts ultra-low noise rolling bearing, ensuring low-noise operation. The airflow through the coils is uniform and not concentrated in the middle part of the coil thanks to the large distance between the coil and the fan, which greatly reduces the airflow noise.

## High-efficiency Heat Exchange

The water flow from the distributor is even with low water resistance and high heat exchange efficiency.

## Specification

### Ceiling Unconcealed Fan Coil Unit

Model(HFPE-**WM/BY03)		34	51	68	85	102	119	136	170	204	238		
Model(HFPE-**WM/BZ03)		34	51	68	85	102	119	136	170	204	238		
Air Flow Rate	H	CFM	200	300	400	500	600	700	800	1000	1200	1400	
		m³/h	340	510	680	850	1020	1190	1360	1700	2040	2380	
	M	m³/h	279	418	558	697	836	976	1115	1394	1673	1952	
Cooling Capacity	L	m³/h	170	255	340	425	510	595	680	850	1020	1190	
		H	W	2260	3100	4100	4850	5830	6800	7920	9070	10950	12600
		M	W	1930	2660	3550	4234	5090	5950	6720	7890	9590	10890
Heating Capacity	60°C Inlet	H	W	1300	1820	2430	2920	3480	4080	4650	5490	6680	7660
		M	W	3500	5200	6680	7850	9380	11025	12790	14950	18380	21500
		L	W	2960	4400	5690	66730	7800	9410	10900	12760	15700	18460
	45°C Inlet	H	W	1920	2870	3750	4440	5310	6240	7230	8530	10540	12330
		M	W	2260	3100	4100	4850	5830	6615	7510	9070	10950	12600
		L	W	1820	2700	3500	4120	4900	5730	6710	7780	9610	11000
Power Input	H	W	41	57	70	87	103	125	150	174	210	253	
Operation Current	H	A	0.19	0.26	0.32	0.40	0.47	0.57	0.68	0.79	0.95	1.15	
Noise	H	dB(A)	38	40.5	43	46	46	47	47.5	49.5	51	51.5	
Water Flow		m³/h	0.39	0.53	0.71	0.83	1.00	1.17	1.34	1.56	1.88	2.17	
Water Resistance		kPa	22	21	30	28	40	38	38	36	40	44	
Coil	Type	High-quality copper tube with hyperbolic louver type hydrophilic aluminum fin by mechanical expansion											
	Operation Pressure	1.6MPa											
Fan	Type	Forward inclined multi-wing galvanized steel centrifugal double suction impeller											
	Quantity	pcs	1	2	2	2	2	2	3	4	4	4	
Motor	Type	Ball bearing single-phase capacitor motor											
	Quantity		1	1	1	1	1	1	2	2	2	2	
	Power Supply	AC 1Φ, 220V/50Hz											
	Protection Class	IP20											
Pipe Diameter	Inlet/Outlet Pipe	Rc 3/4											
	Drain Pipe	φ21mm (External hose φ16mm)											
Net Dimensions	L	mm	911	1051	1131	1181	1281	1481	1661	1711	1961	2221	
	W	mm	527										
	H	mm	272										
Package Dimensions (L*W*H)	mm	931*293*560	1071*293*560	1151*293*560	1201*293*560	1301*293*560	1501*293*560	1681*293*560	1731*293*560	1971*293*560	2243*293*560		
Net Weight	kg	21.8	26.0	29.6	31.7	36.0	40.9	45.5	52.7	58.6	66.6		

Notes:

- Cooling capacity is tested under the condition: inlet air temp. 27°C DB/19.5°C WB; inlet water temp. 7°C; outlet water temp. 12°C.
- Heating capacity(inlet water temp. 60°C) is tested under the condition: inlet air temp. 21°C DB; inlet water temp. 60°C.  
(Tested under the same water flow conditions as the cooling conditions)
- Heating capacity(inlet water temp. 45°C) is tested under the condition: inlet air temp. 21°C DB; inlet water temp. 45°C.  
(Tested under the same water flow conditions as the cooling conditions)
- The sound pressure in the table is measured in the semi-anechoic room (according to GB/T 19232-2019).
- The data in the table are all tested under 220V~/50Hz power supply.



Floor Unconcealed Fan Coil Unit

Model(HFPE-**LM/BY03)		34	51	68	85	102	119	136	170	204	238		
Model(HFPE-**LM/BZ03)		34	51	68	85	102	119	136	170	204	238		
Air Flow Rate	H	CFM	200	300	400	500	600	700	800	1000	1200	1400	
		m <sup>3</sup> /h	340	510	680	850	1020	1190	1360	1700	2040	2380	
	M	m <sup>3</sup> /h	255	383	510	638	765	893	1020	1275	1530	1785	
Cooling Capacity	H	W	1800	2700	3600	4500	5400	6300	7200	9000	10800	12600	
		M	W	1440	2160	2880	3600	4320	5040	5760	7200	8640	10080
		L	W	1080	1620	2160	2700	3240	3780	4320	5400	6480	7560
Heating Capacity	60°C Inlet	H	W	2700	4050	5400	6750	8100	9450	10800	13500	18900	
		M	W	2160	3240	4320	5400	6480	7560	8640	10800	12960	15120
		L	W	1620	2340	3240	4050	4860	5670	6480	8100	9720	11340
	45°C Inlet	H	W	1800	2700	3600	4500	5400	6300	7200	9000	10800	12600
		M	W	1440	2160	2880	3600	4320	5040	5760	7200	8640	10080
		L	W	1080	1620	2160	2700	3240	3780	4320	5400	6480	7560
Noise		dB(A)	37	39	41	43	45	46	46	48	50	52	
Water Flow		m <sup>3</sup> /h	0.32	0.5	0.61	0.78	0.94	1.1	1.2	1.65	2.15		
Water Resistance		kPa	30	30	30	30	40	40	40	40	50		
Fan	Type	Forward inclined multi-wing galvanized steel centrifugal double suction impeller											
	Quantity	pcs	1	2				4					
Motor	Type	Ball bearing single-phase capacitor motor											
	Quantity		1	1	1	1	1	1	2	2	2	2	
	Power Supply	AC 1Φ, 220V/50Hz											
	Protection Class	IP20											
Pipe Diameter	Insulation Class	B											
	Inlet/Outlet Pipe	ZG3/4"											
	Drain Pipe	φ 20											
Net Dimensions	L × D × H (Without footing)	mm	1015*485*246			1370*485*246			1725*485*246			2080*485*246	
	L × D × H (With footing)	mm	1015*585*246			1370*585*246			1725*585*246			2080*585*246	
Package Dimensions	L × D × H	mm	1115*290*520			1470*290*520			1825*290*520			2180*290*520	
Net Weight	Without footing	kg	19.9		20.4		27.5		37.5		44.5		
	With footing	kg	20.6		21.1		28.2		38.2		45.2		

Notes:

- Cooling capacity is tested under the condition: inlet air temp. 27°C DB/19.5°C WB; inlet water temp. 7°C; outlet water temp. 12°C.
- Heating capacity(inlet water temp. 60°C) is tested under the condition: inlet air temp. 21°C DB; inlet water temp. 60°C.  
(Tested under the same water flow conditions as the cooling conditions)
- Heating capacity(inlet water temp. 45°C) is tested under the condition: inlet air temp. 21°C DB; inlet water temp. 45°C.  
(Tested under the same water flow conditions as the cooling conditions)
- The sound pressure in the table is measured in the semi-anechoic room (according to GB/T 19232-2019).
- The data in the table are all tested under 220V~/50Hz power supply.

Dimensions

Ceiling Unconcealed Fan Coil Unit

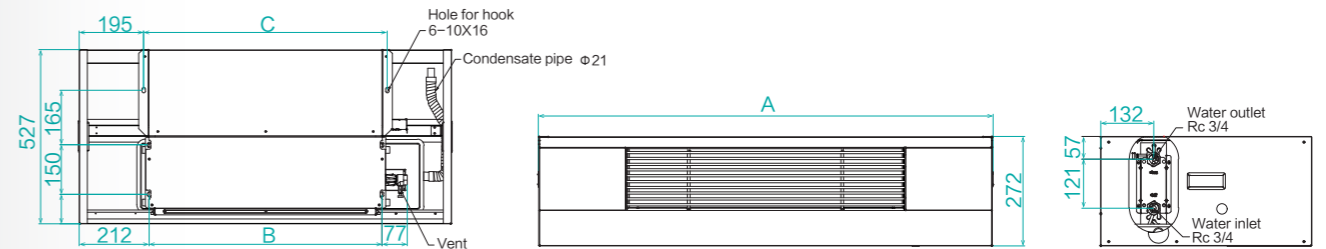

Model HFPE-**WM/BZ(Y)03	34	51	68	85	102	119	136	170	204	238
A	911	1051	1131	1181	1281	1481	1661	1711	1961	2221
B	487	627	707	757	857	1057	1237	1287	1537	1797
C	520	660	740	790	890	1090	1270	1320	1570	1830

Floor Unconcealed Fan Coil Unit

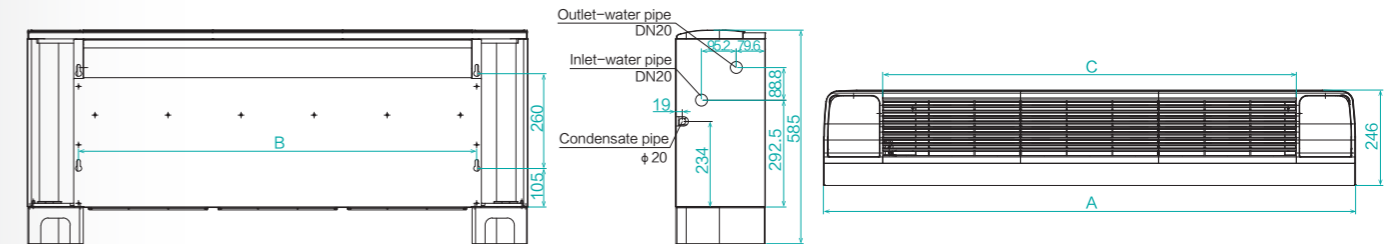

Model HFPE-**LM/BZ(Y)03	34	51	68	85	102	119	136	170	204	238
A	1015	1015	1015	1015	1370	1370	1725	1725	2080	2080
B	735	735	735	735	1090	1090	1445	1445	1800	1800
C	710	710	710	710	1065	1065	1420	1420	1775	1775
Footing height	100	100	100	100	100	100	100	100	100	100



# DC CASSETTE FAN COIL UNIT



## High Efficiency

A brushless DC permanent magnet motor is adopted, with lower energy consumption. Also, the fan motor owns six fan speeds, satisfying various requirements.



## DC High-lift Drain Pump

A DC high-lift drain pump is fitted as standard, which increases the installation flexibility.

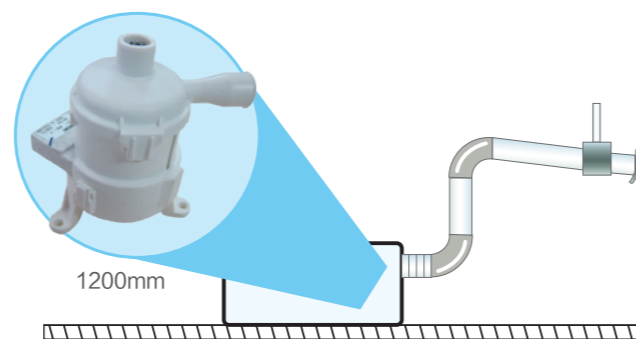

## Breeze Mode

The microhole on the corner of the panel enables breeze mode, to blow out cold wind without cold draft.

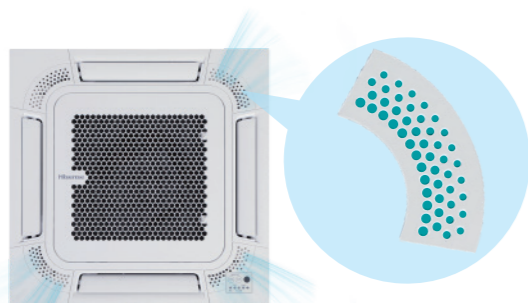

## New Designed Centrifugal Fan

The diameter of the fan is enlarged based on aerodynamic theory, which decreases air resistance a lot, so it creates high efficiency and reduces noise level. Besides, the turbine is assembled by laser welding, which further improves its stability, while reducing weight and lowering energy consumption.

# Specification

Model(HFPE-**K4M/DC)			34	51	68	85	102	119	136	170	204	238
Rated Air Flow Rate	SHi	CFM	200	300	400	500	600	700	800	1000	1200	1400
		m³/h	340	510	680	850	1020	1190	1360	1700	2040	2380
	m³/h	Hi	320	485	645	765	920	1010	1225	1530	1795	2025
		Me	290	435	545	680	805	895	1155	1360	1645	1785
		Lo	240	355	480	595	715	770	1020	1190	1430	1540
		SSL	170	255	340	380	460	540	605	765	920	1070
Rated Cooling Capacity (7°C Water Inlet)	Total	SHi	2250	3200	4550	5200	6200	6800	8500	9900	11200	12680
	Sensible	SHi	1598	2336	3231	3692	4402	4828	6205	7227	8400	9510
Heating Capacity(45°C Water inlet)	SHi	2250	3200	4550	5200	6200	6800	8500	9900	11200	12680	
Heating Capacity(60°C Water inlet)	SHi	3500	5100	7200	8000	9800	10500	13600	16200	18200	20000	
Power Input	SHi	W	10	22	15	19	29	38	40	65	97	143
Sound Pressure dB(A)	SHi	dB(A)	28.5	39.0	27.5	30.5	35.5	38.0	37.5	43.5	48.0	51.0
			Hi	26.0	36.5	25.0	29.0	33.0	36.0	36.5	41.5	46.0
	Me		23.0	32.5	22.0	27.0	31.0	34.0	34.0	38.0	43.5	46.0
	Lo		21.0	28.0	21.0	23.0	27.0	30.0	30.0	34.0	39.5	43.0
	Slo		20.0	23.0	20.0	21.0	22.5	26.0	25.0	30.5	33.0	35.0
	SSL		19.0	22.0	19.0	20.0	21.0	22.0	22.0	23.5	27.0	31.0
Rated Water Flow		m³/h	0.39	0.55	0.78	0.89	1.07	1.17	1.46	1.70	1.93	2.18
Water Pressure Drop	Cooling	kPa	14	20	18	22	28	33	20	28	38	48
	Heating(60°C Water inlet)	kPa	11	18	15	19	26	28	19	26	32	38
Coil	Type	—	Copper and Hydrophilic aluminum									
	Max.Operation Pressure	Mpa	1.6									
Fan	Type	—	Centrifugal, backward-curved Blades									
	Quantity	pcs	1	1	1	1	1	1	1	1	1	1
Motor	Type	—	Permanent Magnet Brushless DC									
	Quantity	pcs	1	1	1	1	1	1	1	1	1	1
	Power Supply	—	AC 1Φ, 220~240V, 50/60Hz									
	Protection Level	—	IP20									
	Insulation Grade	—	B									
Water Inlet/Outlet Pipe		inch	RC 3/4" Cone tube with internal thread									
Condensate Drain Pipe		inch	VP25(OD ϕ 32)									
Net Dimensions (without Panel)	Width	mm	570	570	840	840	840	840	840	840	840	840
	Depth	mm	570	570	840	840	840	840	840	840	840	840
	Height	mm	215	215	238	238	238	238	288	288	288	288
Panel Net Dimensions	Width	mm	620	620	950	950	950	950	950	950	950	950
	Depth	mm	620	620	950	950	950	950	950	950	950	950
	Height	mm	37	37	39	39	39	39	39	39	39	39
Net Weight (without Panel)		kg	14.9	14.9	21.5	21.5	21.5	21.5	25.6	25.6	25.6	25.6
Panel Net Weight		kg	2.8	2.8	5.8	5.8	5.8	5.8	5.8	5.8	5.8	5.8
Controller		Wireless controller HYE-VD01 as standard										

Notes:

1. The nominal cooling capacity and heating capacity are based on the following conditions:

Cooling operation conditions: indoor air inlet temperature: 27°C DB 19.5°C WB, Inlet water temperature: 7°C, Outlet water temperature: 12°C.

Heating operation conditions: indoor air inlet temperature: 21°C DB, Inlet water temperature: 60°C/45°C.

2. Rated air volume is tested based on following conditions: standard air condition, dry coil condition(20°C DB).

3. Shi, Hi, Me, Lo, Slo, and SSI in the table represent super high, high, medium, low, super low and breeze.



Correction Coefficient of Cooling Capacity under Variable Working Conditions

Indoor air inlet temperature: 27°C DB/ 19.5°C WB																	
Model	Water flow (m³/h)	Inlet water temperature ( °C )															
		5		6		7		8		9		10		11		12	
		Total	Sensible	Total	Sensible	Total	Sensible	Total	Sensible	Total	Sensible	Total	Sensible	Total	Sensible	Total	Sensible
HFPE-34K4M/DC	0.39	1.14	1.14	1.05	1.05	1	1	0.93	0.93	0.85	0.85	0.78	0.78	0.71	0.71	0.65	0.65
HFPE-51K4M/DC	0.55	1.14	1.14	1.05	1.05	1	1	0.93	0.93	0.85	0.85	0.78	0.78	0.71	0.71	0.65	0.65
HFPE-68K4M/DC	0.78	1.14	1.14	1.05	1.05	1	1	0.93	0.93	0.85	0.85	0.78	0.78	0.71	0.71	0.65	0.65
HFPE-85K4M/DC	0.89	1.14	1.14	1.05	1.05	1	1	0.93	0.93	0.85	0.85	0.78	0.78	0.71	0.71	0.65	0.65
HFPE-102K4M/DC	1.07	1.14	1.14	1.05	1.05	1	1	0.93	0.93	0.85	0.85	0.78	0.78	0.71	0.71	0.65	0.65
HFPE-119K4M/DC	1.17	1.14	1.14	1.05	1.05	1	1	0.93	0.93	0.85	0.85	0.78	0.78	0.71	0.71	0.65	0.65
HFPE-136K4M/DC	1.46	1.15	1.15	1.07	1.07	1	1	0.94	0.94	0.86	0.86	0.79	0.79	0.72	0.72	0.64	0.64
HFPE-170K4M/DC	1.70	1.15	1.15	1.07	1.07	1	1	0.94	0.94	0.86	0.86	0.79	0.79	0.72	0.72	0.64	0.64
HFPE-204K4M/DC	1.93	1.15	1.15	1.07	1.07	1	1	0.94	0.94	0.86	0.86	0.79	0.79	0.72	0.72	0.64	0.64
HFPE-238K4M/DC	2.18	1.15	1.15	1.07	1.07	1	1	0.94	0.94	0.86	0.86	0.79	0.79	0.72	0.72	0.64	0.64

DB/°C \ WB/°C	23°C		24°C		25°C		26°C		27°C		28°C	
	Total	Sensible	Total	Sensible	Total	Sensible	Total	Sensible	Total	Sensible	Total	Sensible
16.5	0.72	0.83										
17.0			0.79	0.89								
18.0					0.87	0.94	0.87	0.99				
19.0							0.95	0.97	0.99	1.04		
19.5									1.00	1.00		
20.0									1.03	0.98	1.04	1.06
21.0											1.12	1.01

Correction Coefficient Of Heating Capacity under Variable Working Conditions

Indoor air inlet temperature: 21°C DB							
Model	Water flow (m³/h)	Inlet water temperature ( °C )					
		35	40	45	50	55	60
HFPE-34K4M/DC	0.39	0.33	0.46	0.64	0.76	0.87	1
HFPE-51K4M/DC	0.55	0.32	0.45	0.63	0.75	0.86	1
HFPE-68K4M/DC	0.78	0.32	0.45	0.63	0.75	0.86	1
HFPE-85K4M/DC	0.89	0.34	0.47	0.65	0.77	0.88	1
HFPE-102K4M/DC	1.07	0.32	0.45	0.63	0.75	0.86	1
HFPE-119K4M/DC	1.17	0.34	0.47	0.65	0.77	0.88	1
HFPE-136K4M/DC	1.46	0.32	0.45	0.63	0.75	0.86	1
HFPE-170K4M/DC	1.70	0.30	0.43	0.61	0.73	0.84	1
HFPE-204K4M/DC	1.93	0.31	0.44	0.62	0.74	0.85	1
HFPE-238K4M/DC	2.18	0.32	0.45	0.63	0.75	0.86	1

DB/°C	19°C	20°C	21°C	22°C	23°C	24°C
Heating	1.06	1.03	1.00	0.98	0.94	0.92



## Dimensions

### DC Cassette Fan Coil Unit

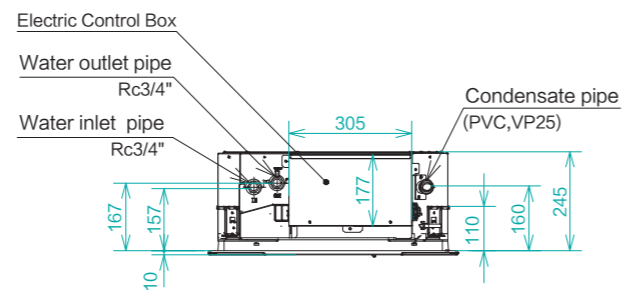
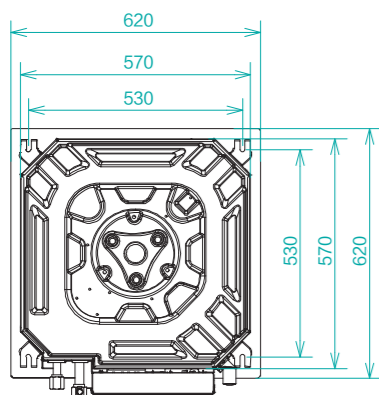

Model: HFPE-34K4M/DC, HFPE-51K4M/DC

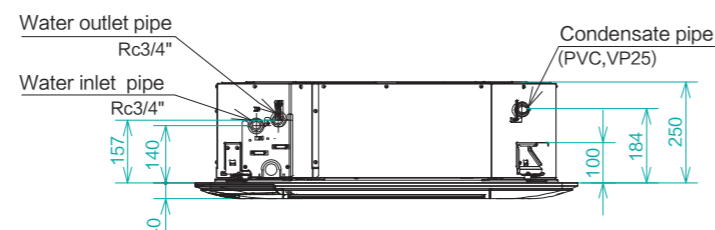
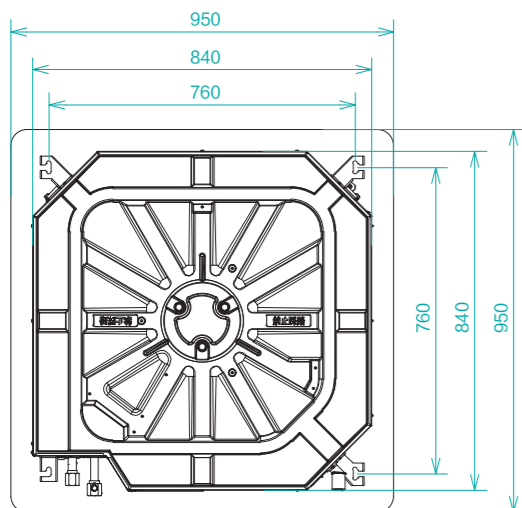

Model: HFPE-68K4M/DC, HFPE-85K4M/DC, HFPE-102K4M/DC, HFPE-119K4M/DC

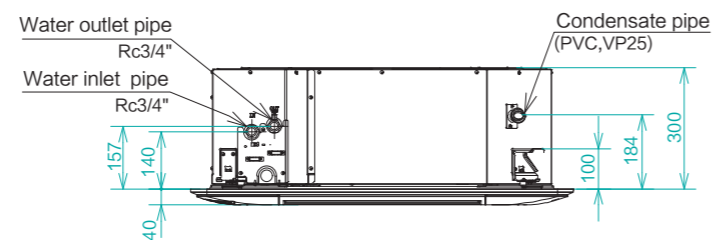
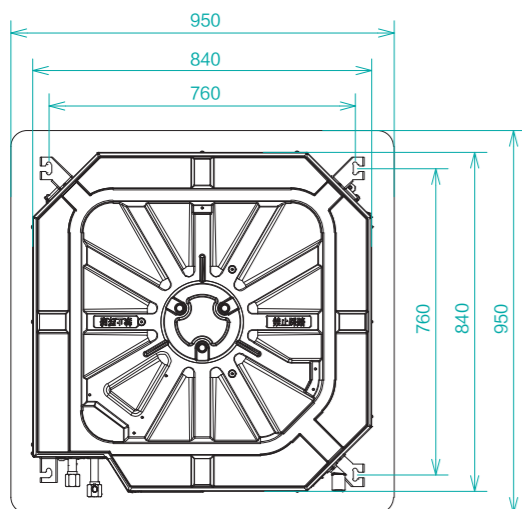

Model: HFPE-136K4M/DC, HFPE-170K4M/DC, HFPE-204K4M/DC, HFPE-238K4M/DC

## AC CASSETTE FAN COIL UNIT



### 360° Surround Air Flow for Comfort

4-way cassette fan coil units could achieve 360° surround air delivery to obtain a more uniform air temperature distribution.

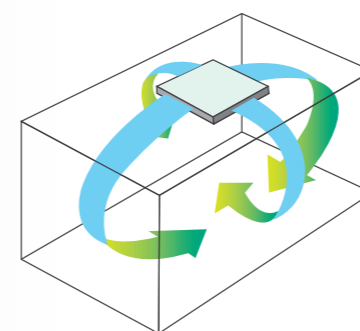

### Elegant Appearance

The 4-way cassette fan coil has beautiful appearance which could easily match with different interior decoration styles, offering a pleasant environment.

### Standard with High Head Drain Pump

The drain pump with high head of 750mm is built in the unit, so the condensate water piping can be more flexibly. What's more, the float switch is also equipped, which can alarm warning due to the malfunction of draining, thus avoiding leakage of drain water.

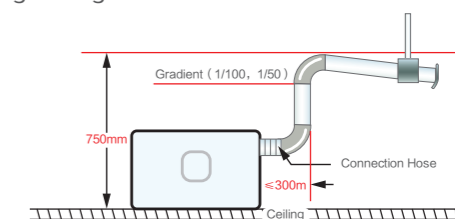

### High Efficiency and Low Noise Thanks to the Turbo Fan

The new type of turbo fan uses aviation level 3D spiral blades, which effectively reduces airflow resistance and expands the heat dissipation area, so that the airflow is balanced and stable. What's more, it eliminates vibration and noise, and together with low-noise motors, supplying comfortable and quiet environment.



## Specification

Model (HFPE-**K4M/E)			51	68	85	102	119	136	170	204	238	
Air Flow Rate	H	CFM	300	400	500	600	700	800	1000	1200	1400	
		m³/h	510	680	850	1020	1190	1360	1700	2040	2380	
	M	m³/h	383	510	638	765	893	1020	1275	1530	1785	
	L	m³/h	255	340	425	510	595	680	850	1020	1190	
Cooling Capacity	H	W	2700	3600	4500	5400	6300	7200	9000	10800	12600	
	M	W	2160	2880	3600	4320	5040	5760	7200	8640	10080	
	L	W	1620	2160	2700	3240	3780	4320	5400	6480	7560	
Heating Capacity 60°C Inlet Water	H	W	4050	5400	6750	8100	9450	10800	13500	16200	18900	
	M	W	3240	4320	5400	6480	7560	8640	10800	12960	15120	
	L	W	2340	3240	4050	4860	5670	6480	8100	9720	11340	
Heating Capacity 45°C Inlet Water	H	W	2700	3600	4500	5400	6300	7200	9000	10800	12600	
	M	W	2160	2880	3600	4320	5040	5760	7200	8640	10080	
	L	W	1620	2160	2700	3240	3780	4320	5400	6480	7560	
Noise		dB(A)	39	41	43	45	46	46	48	50	52	
Fan	Centrifugal Fan											
Motor	Power Supply	V/Ph/Hz	AC 1 φ, 220V/50Hz									
	Power Input	W	50	60	74	93	112	130	147	183	221	
	Current	A	0.23	0.27	0.34	0.42	0.51	0.59	0.67	0.83	1	
Water Flow		m³/h	0.5	0.61	0.78	0.94	1.1	1.2	1.65	1.85	2.15	
Water Resistance		kPa	30	30	30	40	40	40	40	40	50	
Pipe Diameter	Inlet/Outlet Pipe	in	ZG3/4"									
	Drain Pipe	mm	φ 26									
Dimensions (L × D × H)	Unit	mm	660*660*190			660*660*290			760*760*290		860*860*290	
	Panel	mm	750*750*45				850*850*45			950*950*45		
Net Weight		kg	11.6			20			26.5		29	

Notes:

- Cooling capacity is tested under the condition: inlet air temp. 27°C DB/19.5°C WB; inlet water temp. 7°C; outlet water temp. 12°C.
- Heating capacity (inlet water temp. 60°C) is tested under the condition: inlet air temp. 21°C DB; inlet water temp. 60°C.  
(Tested under the same water flow conditions as the cooling conditions)
- Heating capacity (inlet water temp. 45°C) is tested under the condition: inlet air temp. 21°C DB; inlet water temp. 45°C.  
(Tested under the same water flow conditions as the cooling conditions)
- The sound pressure in the table is measured in the semi-anechoic room (according to GB/T 19232-2019).
- The data in the table are all tested under 220V~/50Hz power supply.

## Dimensions

### AC Cassette Fan Coil Unit

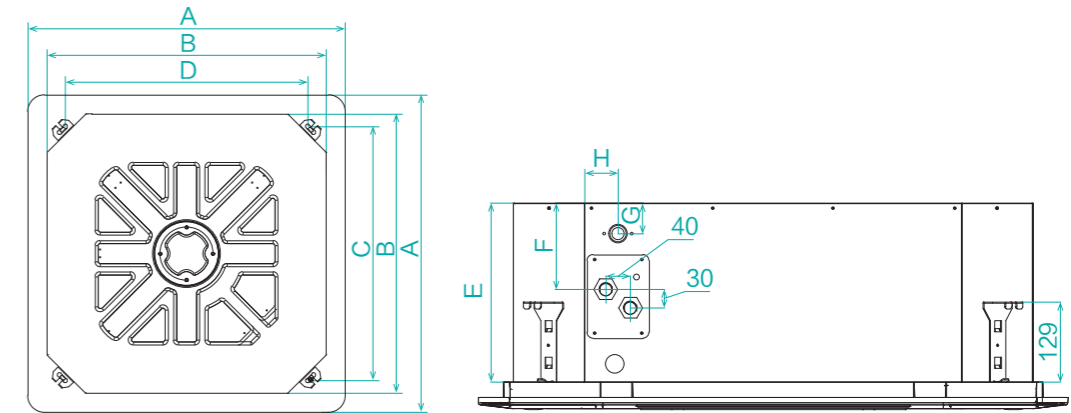

Model HFPE-**K4M/E	A	B	C	D	E	F	G	H
51/68	750	660	578	542	190	85	34	62
85/102/119	750	660	578	542	290	140	50	50
136/170	850	760	678	642	290	140	50	50
204	950	836	763	727	290	140	50	54
238	950	860	763	727	290	140	50	54

